

**DEMOCRATIC SOCIALIST REPUBLIC OF SRI LANKA**

**MINISTRY OF PORTS & HIGHWAYS**

**ROAD DEVELOPMENT AUTHORITY**

**HAMBANTOTA HUB DEVELOPMENT PROJECT  
CONSTRUCTION OF  
EXTENSION OF SOUTHERN EXPRESSWAY FROM WATIYA  
TO ANDARAWEWA**

**CONTRACT AWARDED TO  
CHINA STATE CONSTRUCTION ENGINEERING CORPORATION  
LIMITED**

**CIVIL WORK CONTRACT NO: RDA/RNIP/HH/01**

**VOLUME 3  
TECHNICAL SPECIFICATION  
-SECTION 1 (DIVISION 100 - 400)**

**AUGUST 2013**

8 025

## CONTENTS OF CONTRACT DOCUMENTS

### VOLUME 1

- a) Supplementary Agreement
- b) Appendix to Tender
- c) Minutes of Negotiations, if any.

### VOLUME 2

- d) Particular Conditions of Contract

### VOLUME 3

- e) Technical Specifications – Section I, II and III

### VOLUME 4

- f) Drawings

### VOLUME 5

- g) Scope of Work
- h) Preamble to Bill of Quantities
- i) Bill of Quantities

### VOLUME 6

- j) Supplementary Information

A B2

**DIVISION 100**

**GENERAL**

Section 101	Facilities for the Engineer and Employers	1
Section 102	Facilities for the Contractor and General Requirements	14
Section 103	Major Equipment and Plant	28
Section 104	General Climate Prevailing in Sri Lanka	39
Section 105	Care of the Environment	39
Section 106	Investigations, Design and Preparation of Construction Documents	49
Section 107	Provision of Insurance, Bonds and Securities	50
Section 108	Traffic Management and Maintenance of Existing Roads	50
Section 109	Administrative Costs of the Project Management Unit	52
Section 110	Pay Items and Basis of Payment	53

Appendices

Appendix 1 -	List of Standards
Appendix 2 -	Offices for the Engineer and Employer
Appendix 3 -	Housing and Furniture for Engineer and Employer
Appendix 4 -	Vehicles for the Engineer and Employer
Appendix 5 -	Laboratories for the Engineer
Appendix 6 -	Surveying Equipment for the Engineer

32

**SECTION 100  
SITE ESTABLISHMENT**

**101 FACILITIES FOR THE ENGINEER AND HIS STAFF AND EMPLOYER**

**101.1 General**

The following facilities and services for the Engineer / Employer shall be provided by the Contractor:-

- Housing for the Engineer and Employer with equipment and furniture.
- Site Office(s) with equipment and furniture including telecommunications equipment;
- Laboratory(s) with equipment, apparatus, furniture, and testing consumables;
- Surveying Equipment;
- Vehicles (including drivers) and motorcycles;
- Progress photographs;
- Project sign boards;
- Removal of facilities and equipment upon completion.

Particular requirements in respect of the above facilities and services are detailed in the following clauses and the following shall generally apply:-

1. All matters in respect of facilities or services shall be subject to the Engineer's formal approval. The Contractor shall submit details of all proposals prior to placing orders or making any arrangements.
2. All facilities shall be new except where expressly provided otherwise.
3. Buildings may be prefabricated or of indigenous construction.
4. Notwithstanding any particular requirement detailed below the buildings shall be to contemporary standards, shall comply with national building regulations and legislation and be fit for intended use.
5. All facilities and services shall be for the exclusive use of the Engineer/Employer and their staff during the period of the Contract and as further required to finalise measurement, payment etc. All buildings (officers, houses & laboratories) shall be constructed on lands belonging to RDA shall revert to the RDA on completion of the project.
6. The Contractor shall provide the Office facilities and services as soon as is practical and not later than 90 days after the date of commencement of the work. During the period prior to completion of construction or provision of the regular office accommodation the Contractor shall provide fully functional office accommodation at a suitable location mutually agreed with the Engineer.
7. The Contractor shall provide the Laboratory buildings, facilities, equipment, apparatus and services as soon as is practical and not later than 60 days after the date of commencement of the work. All the equipment shall be mobilized on site and made operational within this period so that it can be checked and approved by the Engineer well in advance of the commencement of construction work so that the testing of materials sources can be commenced as soon as possible.



8. The Contractor shall provide the survey equipment within 60 days of the date of the commencement of the works.
9. The Contractor shall supply all the vehicles as soon as is practical and not later than 60 days after the date of commencement of the work. Prior to the provision of the vehicles the Contractor shall hire and make available to the Engineer / Employer similar vehicles to the approval of the Engineer.
10. The Contractor will be responsible for ensuring that the facilities provided for the Engineer / Employer are secure at all times and shall erect fencing and employ day and night watchmen / security guards.
11. The Contractor shall provide replacement services or facilities whenever any item becomes unavailable or unusable from any cause.
12. The facilities will include the provision of land, site grading, all weather access roads, hard standing parking facilities for vehicles with water supply, hose and vehicle wash down facilities, construction of all necessary appurtenance such as drainage systems, fencing, utilities, landscaping, area development etc.
13. The Contractor shall maintain all facilities for the duration of the Contract, such maintenance shall include but not be limited to:-
  - (a) keeping buildings in good repair and decorative order, and free from pests, insects etc;
  - (b) cleaning offices and laboratory daily;
  - (c) maintaining the grounds around buildings;
  - (d) supplying kitchen-ware and crockery, gas cylinders and refilling and cleaning materials;
  - (e) supplying toilet and cleaning equipment and materials;
  - (f) providing power, drainage, telephone services, fax and e-mail facilities;
  - (g) servicing and repairing all fittings and equipment installed, eg: air-conditioners, fans, cookers etc;
  - (h) provide adequate security for offices and Engineer's laboratory.

#### 101.2 Building Construction

The buildings shall comply with national standards in respect of:

- thermal insulation;
- fire regulations;
- structural design.

The buildings shall be air conditioned within a temperature range of 21°C to 24°C.

Buildings shall also comply with the following requirements:

- a) all windows shall be mosquito proofed;
- b) individual office rooms shall be provided with a floor/ceiling fan;
- c) kitchens and the bathrooms shall be provided with an extractor fan;
- d) all rooms shall be lockable; external doors shall have double mortise locks;
- e) floor coverings for the site offices shall be vinyl or ceramic tiled;
- f) the laboratory floors shall be concrete painted with a sealant;
- g) emergency fire exits shall be provided and shall be clearly marked;
- h) each office and each laboratory shall be provided with a store room;
- i) offices and laboratories shall be provided with a kitchen area, and separate toilets for men and women.

### 101.3 Utilities

All buildings shall be provided with a 220/240 volt electricity supply. Back up provisions shall be provided to all buildings in the form of a standby electricity generator in the event of systematic failure of the main supply. The standby electricity generator shall be of sufficient power to supply the entire peak electricity demand (including air conditioning) of each building. Power points shall be supplied in numbers and at locations to the satisfaction of the Engineer. The power supply shall be fully earthed and shall be subject to power peak protection and voltage regulation.

Buildings shall have a continuous water supply with hot and cold water in the laboratories and in all toilets and kitchens. There shall be a continuous supply of potable water, which may be provided separately through rechargeable dispensers or bottled supply.

Buildings shall be supplied with bottled gas or other fuel as appropriate for the cooking equipment provided.

The Contractor shall be responsible for providing suitable hygienic methods for the treatment and disposal of waterborne sewage, waste water and refuse from all buildings.

The offices shall be wired for a computer Local Area Network as detailed in the Schedule of Office Equipment.

### 101.4 Offices, Equipment and Furnishings

The offices, equipment and furnishings to be provided are described in Appendix 2. The offices, equipment and furnishings shall revert to the Employer at the date of issuing the Taking Over Certificate for the whole of the works, or at such other date instructed by the Engineer. The Contractor shall ensure that the equipment and furnishings are in good condition and in full working order at the time of handing over to the Employer.

A  
02

**B. Measurement**

Offices complete with equipment and furniture as described in Appendix 2 shall be measured as the number of each type of office provided.

The Contractor shall provide all requirement mention in the sections 111.1, 111.2, 111.3 & 111.4.

**b. Payment**

**Payment for each type of office shall include for :-**

- (a) provision of the site for the accommodation, whether purchased or leased;
- (b) preparation of the site;
- (c) provision of the buildings and fixtures;
- (d) water, sanitation, heating, power and lighting services, including standby electricity generation;
- (e) hard standings, access roads, footways, perimeter fencing, security lighting, ancillary works;
- (f) office furnishings and equipment, fittings and protective clothing;
- (g) land line telephone connection(s) and extensions where described in Appendix 2;
- (h) mobile telephones, where described in Appendix 2;
- (i) wireless telephones and extensions, where described in Appendix 2;
- (j) cabling for computer networks(s);
- (k) Air-conditioning
- (l) the provision of temporary accommodation until the permanent offices are available.

Payment for each type of office shall be made upon completion, fully equipping and furnishing and upon occupation by the Engineer's / Employers staff to the extent that they can properly perform their duties.

**101.6 Maintenance of Office of the Engineer and Employer**

**Description**

The Contractor shall maintain in good decorative and working order all the buildings and the contents thereof supplied under the Contract. The Contractor shall be responsible for supplying all power, water and telephone services including mobile telephones to all the facilities and shall meet all costs for these services as further detailed in Appendix 2 and settlement of all bills for these services.

↑  
DS

The Contractor shall maintain all facilities for the duration of the Contract, such maintenance shall include but not be limited to:-

- (a) keeping buildings in good repair and decorative order, and free from pests, insects etc;
- (b) cleaning offices and laboratory daily;
- (c) maintaining the grounds around buildings;
- (d) supplying kitchen-ware and crockery, gas cylinder and refilling as required and cleaning materials;
- (e) supplying toilet and cleaning equipment and materials;
- (f) providing power, drainage, telephone services, fax and e-mail facilities;
- (g) servicing and repairing all fittings and equipment installed, eg: air-conditioners, fans, cookers etc;
- (h) provide adequate security for offices and Engineer's laboratory.

### **Measurement and Payment**

#### **a. Measurement**

Maintenance of each facility shall be measured as the number of months during which the maintenance for each facility is satisfactorily provided. Maintenance shall not be measured during any period occurring between the expiration of the contract period (including awarded Extension of Time) and the date the works are certified as complete. Measurement will be made for maintenance performed after the completion of the works, during the time the facilities are required by the Engineer's staff for post-construction contract completion activities.

#### **a. Payment**

Payment for maintenance for each facility shall include all labor, materials and equipment required for satisfactory maintenance of the facilities and shall include all other costs including but not limited to supply of electricity, water and telephone facilities, cleaning, guarding, disposal of rubbish, repairing equipment and all other work required to ensure the facilities and equipment provided are in good operational order.

### **101.6 Housing for the Engineer / Employer**

#### **Description**

The housing to be provided for the Engineer / Employer's use is described in Appendix 3. Houses provided shall be available and ready for use within 90 days after the Commencement Date, unless otherwise agreed to by the Engineer. Until such time the houses are available the Contractor shall provide facility by renting suitable houses. Housing shall include a separate unit for the use of the driver.

*Handwritten initials:*  
A  
BJ

In the event the housing is not provided within the prescribed period or is not to the satisfaction of the Engineer, all costs associated with the provision, operation and maintenance of the housing, after the expiration of the period will be recovered from the Contractor.

The fittings, furnishing and equipment to be provided in the houses are described in Appendix 3. The houses and fittings and furniture equipment shall remain the property of the Employer on completion of the Works.

Housing for the Engineer / Employer shall be air-conditioning.

#### **Measurement and Payment**

Payment for houses shall include for:

Connection and subsequent disconnection of electrical, telephone and water services or alternative provision of same.

Provision of drainage systems for both sewerage and surface water. Provision of air-conditioning.

Payment for houses shall be made upon satisfactory provision of houses and upon occupation by the Employer or his staff.

The payments for houses shall represent full and final payment for the Contract Items and Contractor shall not be entitled to any further compensation irrespective of any increase to the Contract period for whatever reason.

#### **101.7 Maintenance of Housing of the Employer/ Engineer**

##### **Description**

The Contractor shall maintain in good decorative and working order all the buildings and the contents thereof supplied under the Contract. The Contractor shall be responsible for supplying all power, water and telephone services to all the facilities and shall meet all costs for these services as further detailed in Appendix 3. The Contractor shall also responsible for maintaining the air-condition.

The Maintenance of the Employer's / Engineer's Houses shall include daily cleaning to the satisfaction of the Engineer and provision of toilet materials and other consumables.

The Contractor shall maintain in good condition, service regularly and repair or replace as required, all items of furniture, fittings and equipment installed in the houses including air conditioners.

The Contractor shall provide adequate security to guard and secure the facilities on a 24 hours per day basis for Employer's/ Engineer's Houses.

↑  
DW

## Measurement and Payment

### a. Measurement

Maintenance of each facility shall be measured as the number of months during which the maintenance for each facility is satisfactorily provided. Maintenance shall not be measured during any period occurring between the expiration of the contract period (including awarded Extension of Time) and the date the works are certified as complete. Measurement will be made for maintenance performed after the completion of the works, during the time the facilities are required by the Employer's /Engineer's staff for post-construction contract completion activities.

### b. Payment

Payment for maintenance for each facility shall include all labor, materials and equipment required for satisfactory maintenance of the facilities and shall include all other costs including but not limited to supply of electricity, water and telephone facilities, air- condition facilities, cleaning, guarding, disposal of rubbish, repairing equipment and all other work required to ensure the facilities and equipment provided are in good operational order.

## 101.8 Vehicles for the Engineer and Employer

### Description

The Contractor shall supply the vehicles (including motorcycles) described in Appendix 4. All vehicles shall be new, plain coloured and approved by the Engineer. The vehicles are for the exclusive use of the Engineer, his staff and the Employer. The vehicles shall be licensed and insured for use on the public highway with comprehensive insurance cover for any qualified driver authorized by the Engineer, together with insurance cover for all authorized passengers and for the carriage of goods or samples.

All other vehicles shall be based in Project area except Employers Vehicles.

The Contractor shall provide a competent, qualified driver for each vehicle (except motorcycles). The drivers shall hold a valid driver's license and shall be subject to the approval of the Engineer at commencement of their duties and throughout their employment.

The Contractor shall provide fuel, oil and maintenance (including replacement of tyres) in conformity with the manufacturers recommendations and shall clean the vehicles inside and outside, and fuel and oil the vehicles on a daily basis.

A suitable replacement vehicle shall be provided for any vehicle that is out of service for whatever reason for longer than 24 hours.

Vehicles shall be provided for as long as they are required by the Engineers staff or Employer in connection with the Contract, including a period beyond the certified date for Completion of the Works.

Vehicles provided under the Contract may be required by the Engineer or the Employer to travel outside of the contract limits. The Contractor shall provide all fuel and oil for such journeys and shall pay the drivers an appropriate and adequate accommodation and meal allowance when such journeys involve an overnight stay.

After completion of the project the vehicle shall be the property of the Employer.



**a. Measurement and Payment**

**i. Supply of Vehicles**

Payment for this supply of vehicles shall include the followings and will be paid through Provisional Sums.

- (a) supply and delivery to the Engineer's site offices of the vehicle(s) and ancillary equipment;
- (b) all necessary registration and licensing documents for full and immediate road use;
- (c) initial service;
- (d) provision of temporary vehicles until the permanent vehicles are available.

The Provisional sums shall include a 15% mark up for the overheads and profit component of the contractor.

**ii. Maintenance of Vehicles**

The measurement for maintenance of the vehicles shall be vehicle month for each type of vehicle provided and maintained. Vehicle not provided for a full month shall be measured on a Pro rate basis.

The rate for the maintenance of vehicles shall be full compensation for :

- (a) equipment; seat covers, covers to the upholstery.
- (b) annual revenue license for use on public highways as appropriate ;
- (c) comprehensive insurance covering the Engineer / Employer and their authorized staff and any driver authorized by the Engineer, and for the carrying goods and samples ;
- (d) provision of a suitable replacement vehicle when a regular vehicle is unavailable or unserviceable for more than 24 hours ;
- (e) depreciation ;
- (f) maintenance in a roadworthy condition and in conformity with the vehicle manufacture's recommendations ;
- (g) fuel, oil , lubricants and other consumables ;
- (h) replacement of tyres when instructed
- (i) cleaning inside and out on a Daily basis ;
- (j) provisions of a full time driver including salaries, all overtime payments and any accommodation payments including overnight accommodation allowance when away from the duty station ;
- (k) Security

## 101.9 Testing Laboratories, Equipment and Services

### Description

The laboratories, equipment and furnishings to be provided are described in Appendix 5. The laboratory building, equipment and furnishings shall revert to the Employer at the date of issuing the Taking Over Certificate for the whole of the works, or at such other date instructed by the Engineer. The Contractor shall ensure that the equipment and furnishings are in good condition and in full working order at the time of handing over to the Employer. The laboratories shall be adjacent to the Resident Engineers office and laboratory shall be provided with a lockable concrete floored storeroom of 10sq.m. minimum floor area.

### Submittals

1. Proposed testing laboratory: Provide details for the mobilization of the laboratory and equipment as part of the mobilization schedule required in accordance with these Specifications.
2. Proposed testing personnel: Accompanying the above data submit a list, together with CVs of all technical personnel the Contractor proposes to employ for testing under this Contract.
3. Schedule for testing: Prepare a master schedule of all items to be tested. By - coordination with the construction schedule, and the specified testing frequencies found in the materials specifications, establish tentative dates for each such activity. Submit this data in preliminary form for the Engineer's review at the beginning of each month.
4. Test Forms: Within 60 (sixty) days from the Commencement of Works, submit proposals for standard test forms to be used on the Contract for all tests required by the Specifications, for the Engineer's approval.

### Execution of Testing

Generally all calibration of equipment and testing work will be carried out by the Contractor under the direction and supervision of the Engineer.

### Codes and Standards

Testing shall be executed strictly in accordance with all pertinent codes, regulations and specified standards. Some of these Standards for testing are given in Appendix 5.

### Personnel

Personnel engaged for the purpose of materials testing shall be sufficiently experienced and familiar with the required material tests and shall have the prior approval of the Engineer.

### Forms

For the actual testing and reporting of test results, only those test forms approved in advance by the Engineer or provided by the Engineer shall be used.

A  
Bw



### **Notification**

To permit the Engineer or his representative to witness any non-routine tests they desire, the Engineer shall be notified of the planned timing of the test at least one hour in advance of its execution.

### **Distribution**

Test reports shall be promptly processed and distributed to ensure that any necessary retesting, replacement of materials, or re-compaction of materials may be carried out with the least delay to the Works.

### **Measurement and Payment**

Laboratories with furniture as described in Appendix 5 shall be measured as the number of each type of laboratory provided. Providing Equipment for the different types of laboratories as given Appendix-5 shall be measured separately and paid as a Lump Sum.

Payment for each Type of laboratory shall Include for:-

- (a) preparation of the site;
- (b) provision of the buildings and fixtures;
- (c) water, sanitation, heating, power and lighting services, including standby electricity generation;
- (d) hard standings, access roads, footways, perimeter fencing, security lighting, ancillary works;
- (e) furnishings and equipment, fittings and protective clothing as described in Appendix 5;
- (f) laboratory and field testing equipment as described in Appendix 5;
- (g) all consumables required for both laboratory and site testing;
- (h) delivery of all soil and materials samples from pits, quarries, suppliers or the completed works by the Contractor and at no additional cost to the Employer;
- (i) land line telephone connection(s) and extensions where described in Appendix 5;
- (j) mobile telephones, where described in Appendix 5;
- (k) wireless telephones and extensions, where described in Appendix 5;
- (l) cabling for computer networks(s);
- (m) the provision of temporary accommodation until the permanent laboratories are available.

The Equipment provided for the laboratories shall be duly calibrated. The cost of carrying out additional calibration of all testing instruments during contract execution and all tests necessary for proper completion of the Works, in accordance with the various specified or implied testing requirements in the Contract Documents shall be borne by the Contractor and all such costs shall be deemed to be already included in the Unit Prices for the maintenance of the laboratories except as provided below.

A  
BS

If any test not intended, nor specified, nor implied to be necessary, nor otherwise provided for in the Contract Documents is ordered by the Engineer, or if the Engineer orders any test to be carried out by a third party or at any place other than the site of the Works or the place of manufacture or fabrication of the materials to be tested, then the cost of these unforeseen tests shall be borne by the Employer unless the test results show the workmanship or materials not to be in accordance with the provisions of the Contract Documents, in which case the cost of the test shall be borne by the Contractor.

Payment for each type of laboratory shall be made upon completion, fully equipping and furnishing and upon occupation by the Engineer's / Employers staff to the extent that they can properly perform their duties.

The Provisional sum shall include a 15% mark up for the overheads and profit component of the contractor.

### **101.10 Survey Equipment**

#### **Description**

The Contractor shall supply the survey equipment described in Appendix 6 for the exclusive use of the Engineer. The Contractor shall be fully responsible for the equipment, which responsibility shall include:-

- b. maintenance, calibration and servicing as required;
- c. repairing all defects, including accidental damage, as required;
- d. replacing any lost or stolen items;
- e. effecting insurance of the equipment against damage or loss.

The equipment shall be supplied and maintained for as long as it is required including the period after Completion of Construction for final measurement purposes. At the end of the contract the survey equipment and consumable shall be revert to The Employer in good condition.

#### **a. Measurement**

The Provisional Sum shall include a 15% mark up for the over head & profit component of the Contract.

#### **b. Payment**

The payment shall represent full payment to the Contractor for the Contract item for the complete period of use and the Contractor shall not be entitled to further compensation irrespective of any increases in the Contract period for whatever reason.

In the event the Contractor fails to maintain, repair or replace any equipment item, the Engineer shall effect such maintenance, repairs or replacement and shall deduct from due payments to the Contractor.



**101.11 Other Facilities for the Engineer**

**a. Clerical and Technical Staff**

**Description**

The Contractor shall provide the Engineer with staff to assist in the administration and supervision of the Works. The staff provided shall be experienced and be capable of performing their allotted duties. The staff shall be nominated by the Employer and the salary will be fixed by the Employer. The Contractor shall ensure the continuity of the services of the selected personnel.

In particular, laboratory and survey assistants shall be capable of assisting the Engineer's staff in material testing and survey work respectively and have at least five years experience in similar works. Draughtsmen shall be conversant in Civil works and have at least 5 years experience in AutoCAD Drafting. Secretaries and the Administrators/Clerks shall be experienced in using computers/word processors and be capable of using the latest version of Microsoft Office computer software and have a good command of the English Language.

**i. Measurement**

The selection of supporting staff and the fixing of their salaries will be done jointly by the Employer and the Engineer. An additional overhead charge of 15% will be paid to the contractor.

**ii. Payment**

Payment for staff shall be made from the provisional sum in the Bill of Quantities. Salary for each category of staff shall be agreed between the Employer, Contractor and the staff concerned prior to the appointment unit rates payable to the contractor shall include EPF,ETF etc payable by the contractor in relation to their employment plus 15% (Fifteen percent) mark-up.

**b. Stationary for the Engineer and Employer**

**Description**

The Contractor shall provide stationery for the Engineer and his staff and the Employer duly requisitioned by authorized personnel. Stationery shall include all consumable items and shall include paper, printing materials (e.g. printer cartridges, printer ribbons, copier toner etc.) and all general office requisites. This item excludes parts, etc., required for repair or replacement in equipment supplied by the Contractor for the offices. Provision of such parts would be included in the Contractor's obligation for maintenance of offices.

**Measurement**

Stationery for the Engineer and Employer shall not be measured but payment shall be based on the original invoices and receipts for stationery material ordered and received by the Office Manager/Engineer's Representative's staff.

→  
BW

**Payment**

Payment for stationery shall be the actual net invoiced price of stationery provided (with all suppliers' discounts deducted) with the mark-up of 15% the net invoiced price added to allow for all procurement and delivery costs incurred by the Contractor. Payment of invoiced cost with the mark-up shall be full payment for stationery provided and shall be made from the provisional sum item contained in the Bill of Quantities.

↑  
BS

## **102 - FACILITIES FOR THE CONTRACTOR AND GENERAL REQUIREMENTS**

### **102.1 - DESCRIPTION**

The Contractor shall make provision for installation, maintenance and removal at the completion of the Works, of his offices, sheds, and shelters. He shall provide and maintain at his own cost sanitary facilities on site, first aid and fire fighting equipment, drinking water facilities, electricity and telephone for the duration of the Contract.

The Contractor shall be responsible for the security of the Site and the safety of public and adjoining property and shall be liable for any claims arising from loss or damage suffered. He shall employ watchmen for this purpose.

All temporary accommodation shall be kept well maintained during the contract period and shall be available for inspection by the Engineer and/or Government Medical Officer of Health. The Contractor must comply immediately with any instruction given by the Engineer and/or Medical Officer for cleaning, disinfecting and maintenance of any building to return it to a hygienic and sanitary condition.

The Contractor shall confine his apparatus, the storage of materials and the operations of his workmen to the limits indicated by law, ordinances, permits, or direction of the Engineer. The Contractor shall erect temporary fences as required by the Engineer. The Site boundary lines shall be to the approval of the Engineer.

The Contractor shall provide and maintain water, electricity and power required for the Works, including that required by the Sub-Contractors, pay all charges and bear all costs for the necessary temporary installation including pipework, pumps, water tankers, storage tanks, generating equipment, etc., and remove on completion, and make good all work disturbed.

### **102.2 - CONSTRUCTION PLANT & WORKSHOP FOR THE CONTRACTOR**

The Contractor shall make provision for the installation, maintenance and removal of fully equipped workshops, stores, and other plants (e.g. crushing, concrete, bitumen etc.) The Contractor shall also provide all necessary construction plant, equipment, tools necessary, and sundry equipment required for any particular trade necessary for the execution and completion of the Works. All plant and equipment required for the Contract is subject to the approval of the Engineer.

### **102.3 - CONTRACTOR'S SITE ORGANISATION**

The Contractor shall employ sufficient qualified staff on site to perform the setting out of the Works as described in the Conditions of Contract, Specifications and Drawings. The Contractor shall also provide the Engineer with all necessary assistance in checking the setting out of the Works, interpreting any information used by the Contractor and to carry out any additional surveying works should these be found necessary for the proper execution of the Works. For these purposes he should supply a minimum 3 chainmen as and when required by the Engineer.

The Contractor shall provide all assistance as required by the Engineer for recording the progress of the Works, monthly statements of the Works and for agreement of final measurement.

The Contractor shall be responsible for all follow up and co-ordination with all utility authorities (electricity, water, drainage, street lighting, telephone, horticulture. etc.).

A  
DF

The Contractor shall provide subject to the approval of the Engineer, qualified and sufficient numbers of engineers, quantity surveyors, supervisors, employees and skilled and non-skilled workmen for his supervision of the Works and site administration.

The Contractor shall provide all unskilled labour and all necessary tools as directed by the Engineer.

If at any time before the commencement or during the progress of the work, the Engineer decides that for the proper execution of any part of the Works, shop drawings are necessary, the Contractor shall prepare these drawings. The drawings shall be submitted to the Engineer for approval at least 14 days prior to the commencement of the relevant work on site.

The Contractor shall not proceed with the above work until the Engineer approves such shop drawings. The Contractor shall not be entitled to any extra payment or extension of time for the preparation of the shop drawings.

#### **102.4 - LABORATORY TESTING**

The specified testing of materials and completed work shall be carried out by the Engineer at the Contractor's expense, and the Contractor shall also be liable to provide labour, transport and packaging to deliver samples etc to the Engineer's Laboratories and shall be at the sole and full-time disposal of the Engineer. The Engineer's Laboratories shall be solely for the Engineer's testing of the Works and of materials to be incorporated therein.

The Contractor shall provide his own laboratory for his own quality control, and trial mix testing etc. The testing of the Works by the Engineer in no way absolves the Contractor from his responsibilities to carry out his own on site quality control testing of the materials and/or workmanship he has performed in completed work items.

The Contractor must make due allowance for the time required for any testing of materials or workmanship etc., within his programme for the Works.

#### **102.5 - PROGRAMME OF WORKS**

The Contractor shall submit to the Engineer for approval a computerized Critical Path Programme and other supporting documentation to indicate how he intends to complete the Works within the time stipulated in the Conditions of Contract. Such documentation should contain, but not be limited to, details of equipment; procedures; material procurement; and timing of works to be completed by other parties.

Due allowance must be made within the Programme for:

- (i) Traffic detour planning and phasing.
- (ii) Maintenance of accesses to all the residential, recreational, business and institutional premises affected by the Works.
- (iii) Any restraints and restrictions imposed by Utility Authorities or the Police.
- (iv) Activities of other Contractors.
- (v) The pavement wearing course and road markings to be laid at such a time to avoid damage by other construction activities.





The Contractor shall, in accordance with the Conditions of Contract, submit a comprehensive plant schedule, which shall include the proposed dates of arrival or establishment on the Site for each major item. Plant shall not be brought to or removed from the Site without the prior approval of the Engineer.

In addition to the Critical Path Programme, the Contractor shall, if required by the Engineer, provide a detailed bar chart schedule to be used by the Engineer for monitoring the progress of the Works.

Furthermore, the Contractor shall submit to the Engineer a daily work programme showing the activities to be undertaken for the day including laboratory tests and survey checks at least 12 days in advance.

#### **102.6 - WORK SITE, SETTING OUT AND CROSS-SECTIONS**

The Employer, through the Engineer shall hand over to the Contractor the work site according to the Drawings. The work site means all land and other locations, which the Employer passes to the Contractor to construct the Works mentioned in the Contract.

The Contractor is responsible for all the setting out of line and levels of the Works, and shall employ adequate qualified staff to carry this out.

Before the commencement of the Works the Contractor will be supplied with the information necessary to establish the lines and levels of the Works. The Engineer has shown on the Drawings all the survey markers established but can give no warranty for their existence at the start of the Contract nor will accept responsibility for replacing any survey markers found to be missing. Where survey markers have been established by the Engineer the Contractor shall check the accuracy of their position and level and shall immediately notify the Engineer of any discrepancies.

All setting out throughout the Works must be related to the Sri Lanka Mean Sea Level. As set by the Government Survey Department. Datum Levels and Survey Stations and values of Bench Marks and survey stations will be handed over by the Engineer to the Contractor. Any Temporary Bench Mark (T.B.M) to be fixed on the Site shall be tied in to the Sri Lanka Survey Department Datum.

The Contractor shall, as soon as practicable, supply the Engineer with records in approved form relating to all reference pegs and bench marks and shall keep such records up to date by formal notice to the Engineer.

All survey reference pegs shall be carefully preserved except where construction requires their removal; no such removal shall be made without the prior approval of the Engineer.

Before commencing work on any section of the Works, the Contractor shall survey and level the original ground surface and shall prepare plans and cross-sections accordingly. These shall, when finally agreed, be signed by the Engineer and Contractor as truly representing the configuration of the areas in question before the commencement of the Works in that section.

All setting out shall be approved in writing by the Engineer before work may commence. The centrelines are to be checked by and approved by the Engineer.

When necessary the Contractor shall provide, at his expense, sufficient templates for approval by the Engineer, to control the finished shape of certain works. These templates shall be in accordance with the specifications and drawings where such are provided. All templates must be approved and shall be maintained in good order to provide the section required for the entire Works.

A  
PS

Templates may be checked from time to time, and any deficiencies noted shall be rectified immediately. The Contractor shall also supply straight edges and lines when required to control the work.

The Engineer will revise the line and/or grade and will require the Contractor to adjust the stake-out accordingly, and also to carry out any additional surveying works should these be found necessary for the proper execution of the Works.

Where directed by the Engineer, the Contractor shall take such levels and dimensions as may be required for the purpose of measurement prior to disturbance of the ground. These shall be agreed between the Contractor and the Engineer before any surface is disturbed or covered up.

Any change of the ground elevation resulting from compaction or other works provided for in the Contract Documents shall be deemed included in such works and paid for within the bid prices listed in the Bill of Quantities. The Contractor shall consequently in no way be entitled to any additional payment or claim whatsoever.

## **102.7 - PROJECT SIGN BOARDS**

### **a. Description**

The Contractor shall erect firmly, sign boards in accordance with the drawings provided in the Contract or as directed by the Engineer. The project Signboard shall be made up of 1.25 m wide, 1.8 m high text in Sinhala, Tamil & English languages. The board shall be galvanized steel of gauge 18 or 25 mm thick marine plywood. The board shall be erected with the bottom of the board at a minimum of 2.3 meters above the adjacent ground and clear of motor traffic with posts and struts suitably set in concrete foundations. The Engineer shall issue to the Contractor the text (in black letters on yellow background), letter sizes, and construction details prior to the start date.

At the end of the Contract, all such sign boards shall be removed and the ground reinstated to the approval of the Engineer.

The project signboards shall be erected within 2 weeks of the commencement of the works.

### **b. Measurement**

Project signboards shall be measured as the number of sign boards, satisfactory provided and installed and accepted by Engineer and maintained throughout the Contract period, and the removal satisfactorily carried out and accepted by the Engineer.

### **c. Payment**

Payment shall be made at the stated unit rate per signboard. The price shall be full compensation for all materials and labour required to perform the work described. Payment for project signboards will be made in the proportion of 70 percent for provision and erection, and 30 percent for maintenance, updating the completion date periodically, removal of board and subsequent reinstatement of the land.



## 102.8 - PROGRESS PHOTOGRAPHS

A minimum of thirty-six (4 sets) photographs shall be taken by the Contractor each month to record the progress of the Works.

Photographs shall be 200 mm x 150 mm, in colour, and shall be marked with date of exposure, and location. Where conventional photography is used, the negatives shall be supplied to the Engineer.

High resolution digital photographs (minimum 3Mb pixel format) will be acceptable, in which case a 'hard copy' (CDRW disc or equal) shall be supplied in lieu of negatives.

### a. Measurement and Payment

Progress photographs shall be measured by the number of months or part thereof.

The rate shall include for:

taking the photographs;

development of the film and prints;

annotating and binding;

delivery of the specified number of prints to the Engineer / Employer;

delivery of negatives, or, in the case of digital photography, submitting or transferring electronic copies of the prints to the Engineer by means of CDRW discs or otherwise.

## 102.9 - QUALITY OF MATERIALS AND SUPPLY

Unless otherwise stated or approved by the Engineer all materials used in the Works shall be new and of the best quality as specified in the Contract. Materials delivered to the Site for the purpose of the Works, shall be accompanied by a "Certificate of Guarantee" signed by the authorised representative of the manufacturer. Such Certificate shall state that the materials specifications and test results are in compliance with the specified requirement of the pertinent designations of the most recent edition of the standards contained in the Contract Documents, or any other approved equivalent standard.

The borrow pit locations if not designated in the Contract Documents shall be approved by the Engineer in liaison with the Employer and/or other concerned Authorities or parties. The Contractor shall exercise a continuous quality control upon the extracted material to confirm its suitability for use. No material shall be supplied to the Site before the Engineer's approval of the type of equipment which the Contractor intends to use in the borrow pit, and for the method of work.

The Contractor shall select rock quarries and shall submit laboratory tested and accepted samples, within sufficient time before their use, in order for the Engineer to determine their conformity with the related Specifications. The Contractor shall exercise a continuous quality control upon the extracted material to confirm its continued suitability for use. No material shall be supplied on the Site before the Engineer's approval of the type of equipment that the Contractor intends to use in the quarry, and for the method of work.

The Engineer's acceptance of the materials does not relieve the Contractor of his total responsibility to carry on with additional investigations in order to obtain and supply during the progress of the Works uniform material conforming to the Specifications.

↑  
BS

The Contractor shall be responsible for payment of royalties, if any, arising due to the obtaining of materials for use in the Works. No separate payment will be made by the Employer as a royalty for materials for use in the Works.

Wherever in the Specifications tests on materials, tests on completed work, and construction control tests are called for or implied, they shall be carried out according to, and the materials shall comply with, the requirements of the Specifications and the latest edition of the applicable standard. The Contractor shall provide for the exclusive use of the Engineer copies of each and all codes of practice, international standards, test methods etc. relevant to the Works. In addition, the Contractor shall retain on the Site for the use of the Engineer all manufacturers' literature relating to all the products to be used in the Works, and the manufacturers' installations instructions for all relevant products, materials components and installations.

Where specific material or equipment is referred to in the Contract, it is intended only to indicate the acceptable standard. The Contractor may offer alternative materials or equipment of an equal standard. The Contractor must submit a statement listing proposed alternatives together with such information and samples as the Engineer may require satisfying that the alternatives offered are of equal quality to the items specified. The costs of submitting and testing such samples will be borne by the Contractor.

The Contractor will be required to produce documentary evidence that all materials which are not available in the local market and which have to be imported have been ordered sufficiently in advance to ensure that no delay to the Works occur. As soon as orders have been placed, copies of such orders shall be submitted to the Engineer. The Contractor shall be responsible for any delays as a result of late ordering.

All specified materials incorporated in the Works shall be fixed or applied strictly in accordance with the manufacturer's printed instructions. Should the Engineer discover in the Works any materials other than those approved, he may order their removal from the Site and replacement with approved materials at no cost to the Employer and in compliance with the Specifications.

The Bill of Quantities shall NOT be used as a basis for ordering materials, and the Contractor is entirely responsible for assessing the quantities of materials to be ordered.

All materials or manufactured items shall be carefully loaded, transported, unloaded and stored in an approved manner, and protected from damage and exposure to weather or dampness during transit and after delivery to the Site. Damaged material or manufactured items damaged during and after fixing in position shall be removed, repaired or replaced by and at the Contractor's expense. The Contractor shall erect and maintain ample temporary and weatherproof sheds for proper storage and protection of his own and sub-contractors' materials. Cement and other perishable material shall have floors raised 150mm off the ground. The Contractor shall clear away on completion and make good all areas disturbed.

Prior to ordering/delivering any material, or manufactured items, to the Site, the name and address of the supplier(s) shall be submitted to the Engineer for approval.

Where required by the Engineer, adequate samples, sample schedules and manufacturers' certificates of all the materials and goods to be used in the Works shall also be submitted to the Engineer for approval, and in the case of rejection further samples shall be submitted until such are approved. The cost of submitting all such samples shall be borne by the Contractor. If judged necessary by the Engineer the samples shall be tested for compliance with the Specifications. Approval of a source does not mean that all the materials from that source are approved. No source of supply shall be changed without Engineer's prior approval.

A  
QS

Approved samples shall be retained on the Site for comparison with products/materials incorporated in the Works, and shall be removed when no longer required by the Engineer.

#### **102.10 - APPROVAL BY THE ENGINEER**

The Contractor is required to give sufficient notice in writing to the Engineer requesting inspection and approval of various stages of construction of the Works. Unless stated otherwise in the Contract, a notice period of not less than four hours of normal working time shall be given before the work is ready for final inspection. The Contractor shall supply printed forms for this purpose. Further stages of work shall not proceed until the Contractor has received the written approval of the Engineer.

The Contractor shall give the Engineer details of the source of materials to be incorporated into the Works. Reasonable notice must be given by the Contractor to allow the Engineer to carry out such tests and enquiries as may be appropriate before giving approval.

When items to be incorporated into the Works are to be manufactured or fabricated off-site the Contractor shall give the Engineer not less than seven days notice in writing of the commencement of such work.

Where the approval of the Engineer is required under the Specifications, such approval shall not in anyway relieve the Contractor of his duties or responsibilities under the Contract.

#### **102.11 - EXISTING UTILITIES AND UTILITY DIVERSIONS**

The Contractor will be required to liaise with the relevant utility authorities, obtain their respective final quotations for the various relocation works required, and obtain the approval of the Employer for the necessary expenditure. Upon receipt of approval from the Employer, the Contractor shall instruct the utility authorities to commence with the relocation works, and shall be responsible for coordinating his activities with those of the utility authorities in order to avoid conflicts in working locations and such as to complement each others' programme scheduling. Payment for the utility relocation work shall be made by the Contractor to the respective authorities, and he shall be reimbursed for such direct expenditure, together with the percentage mark up stated to cover the Contractor's overheads and profit, from the appropriate Provisional Sums provided in Bill No 900. No additional payment will be made to the Contractor in respect of utility relocation works.

The Contractor will be reimbursed in respect of his costs in discharging his responsibilities under the Contract in regard to utility relocations through application of the percentage mark up stated to the actual costs of the utility diversion works as paid to the various utility authorities. No other payment will be made to the Contractor by the Employer in respect of work undertaken by him in connection with utilities. The cost of precisely locating utilities which are not to be relocated shall be deemed to be spread over the rates and prices entered against the other items of the Bills of Quantities in a manner deemed appropriate by the Contractor.

It is not envisaged that relocation of certain utilities to serve reservation areas will form part of the Works under the Contract.

The positions of all public and privately owned utilities shown on the Drawings have been based on the records of various utilities and Public Authorities and must be regarded as approximate. The Contractor must verify this information and satisfy himself as to the exact nature and position of all such apparatus. The Engineer does not guarantee the accuracy of the information given on the Drawings and no warranty is given or implied.

A  
GL

The Contractor shall take into account the current laws regarding the safety of utility lines, together with any amendment or additions thereto. The Contractor shall include in his bid for anything in these laws considered to have a monetary value/implication.

The cost of locating or verifying the location of existing utilities, liaison with the various Utility Authorities, and complying with the above shall be borne by the Contractor unless provided for elsewhere in the Contract.

Before opening the ground for any purpose, the Contractor shall notify all concerned parties by issue of formal "Notice of Intent" and must obtain information by Formal Notice regarding the location of all utilities. The complete responsibility for obtaining this information rests with the Contractor. The "Notice of Intent" shall be circulated to all concerned parties, and shall include the following:

Drawings and notices shall be sent in triplicate one of which shall be retained by the addressee and the other two returned to the sender duly marked to show underground utilities. "Notice of Intent" will be given 14 (fourteen) days in advance of the proposed Works. In the event that the work is not started within 8 (eight) weeks of the date of the "Notice of Intent" it will be deemed to have lapsed. A further Notice of Intent shall then be submitted.

The Contractor shall furnish copies of the above Notices of Intent to the Engineer. The Contractor shall acquaint himself with the position of all existing utilities and must obtain clearance from the relevant authority before commencing any work in a particular area. Written evidence of such clearance shall be provided to the Engineer by the Contractor. If any underground utility line is encountered unexpectedly, excavation shall cease, and the Engineer's Representative shall be notified immediately. Emergency work, as necessary, shall be put in hand without delay and without prejudice to the indemnity of the Employer.

The Contractor shall prepare records and drawings showing position, levels and types of each existing utility, including manholes, joint boxes and inspection chambers etc. All record drawings shall be prepared using a Computer Aided Drafting program approved by the Engineer. Soft Copy containing the drawings data shall be supplied to the Engineer in the approved digital format for incorporation in the final record drawings.

The Contractor shall take any and all measures reasonably required by any public or concerned Authority for the support and full protection of all mains, pipes, cables and other apparatus during the progress of the Works, and shall construct and provide to the satisfaction of the Authority concerned, all works necessary for the prevention of damage to utilities or interruption of services.

If in the execution of the Works, by reason of any subsidence caused by any act of neglect, or default of the Contractor, any damage to any apparatus, or any interruption of, or delay to the provision of any service is caused, the Contractor shall report it to the Engineer immediately. The Contractor shall also and bear and pay the cost reasonably incurred by the Authority concerned in making good such damage and shall make full compensation to the Authority for any loss, sustained by reason of such interruption or delay.

The Contractor shall familiarise himself and all his employees with the dangers of working in or near live sewers and at sewage treatment works, in particular to the risks of physical injury from the explosion of dangerous gases and/or bacterial infection from contact with sewage and of exposure to poisonous gases, which may be given off by the sewage. Hydrogen sulphide and methane are prevalent in the sewers and can exist in excavations where septic sewage from collection tanks is allowed to seep into groundwater. In the context of this clause, the term sewer includes irrigation mains and drains carrying ground water and/or storm water.

2  
25



The Contractor shall at all times during the progress of the Works, afford facilities to properly accredited utility agencies to access all or any of their apparatus situated in or under the Site, as may be necessary for inspecting, reporting, maintaining, removing, renewing or altering such apparatus in connection with the construction of the Works or any other purpose whatsoever.

The Contractor will be fully responsible for ensuring observance of the above regulations by his sub-contractors.

Where any utility or service works are to be constructed under a separate contract by the Employer within the Site, concurrent with the execution of the Works, the Contractor shall cooperate with the other Contractor and be responsible to fully coordinate construction operations so as to avoid interference with either Contractor's operations.

The Contractor shall prepare and furnish all necessary shop drawings etc. of the works required to complete the adjustment of existing and/or new apparatus to finished grades or specified levels. The drawings must be approved by both the concerned Utility Authorities and the Engineer prior to commencement of any work at the Site. The Contractor must allow in his rates for utilities installations, and the production of combined service drawings covering the whole of the Contract area. The drawings must show both existing utilities located by trial pits and coordinated by survey, and all proposed new utilities. These drawings are to be used to identify interface problems prior to the production of working drawings and well in advance of works in such locations of possible conflicts.

Drawings must be prepared using a Computer Aided Drawing program approved by the Engineer. Diskettes containing the drawing data of the original utility locations and those containing the drawing data of the relocated original utilities and of the new utility locations together with their protection shall be supplied to the Engineer for incorporation in the final record drawings in the approved digital format.

The Contractor shall also prepare CAD shop drawings for utility protection work and obtain the approval of the appropriate Authority and the Engineer before commencing with construction.

The Contractor shall relocate certain utilities to service reservation areas as specified in the Contract. This work may only include the construction of necessary protective housing (e.g. box culverts, slabs, concrete encased sleeves etc.) in the service reservation areas for utility lines to be relocated. Or this work may include necessary protective housing as described above and, in addition, the relocation of specific utility lines to the service reservation areas. In both cases, the Contractor shall complete the necessary survey to establish the lines and levels, and prepare and submit shop drawings to the Engineer for his review and approval. The Contractor shall obtain approval from any concerned Authority before requesting the approval of the Engineer to commencing such work.

The Contractor will be required to liaise with the relevant utility authorities, obtain their respective final quotations for the various relocation works required, and obtain the approval of the Employer for the necessary expenditure. Upon receipt of approval from the Employer, the Contractor shall instruct the utility authorities to commence with the relocation works, and shall be responsible for coordinating his activities with those of the utility authorities in order to avoid conflicts in working locations and such as to complement each others' programme scheduling. Payment for the utility relocation work shall be made by the Contractor to the respective authorities, and he shall be reimbursed for such direct expenditure, together with the percentage mark up stated to cover the Contractor's overheads and profit, from the appropriate Provisional Sums provided in Bill No 900. No additional payment will be made to the Contractor in respect of utility relocation works.

A  
BS

Any public or private service for water, electricity, drainage, etc., affected by the Works shall not be interrupted without the written permission of the Engineer. Such permission will be withheld until suitable approved permanent or temporary alternative services have been provided by the Contractor or by the owner of the utility or his agents.

Before any temporary traffic diversions, detours or road closures as may be required for the construction of road crossings are constructed full liaison with all the concerned local authorities and Police Departments and their written approval/no objection certificates for same must be submitted to the Engineer prior to work commencing.

Due allowance shall be given by the Contractor, when preparing the Programme of Works, to compliance with this Clause 102.11.

#### **102.12 - PROTECTION AND UPKEEP OF SITE AND ADJACENT AREAS AND PROPERTIES**

The Contractor shall take all necessary precautions to protect buildings, fences, roads, passages, culverts and other apparatus, if found, and he shall not demolish or remove any of these items except according to specific instructions by the Engineer. In the case of existence of buildings, ditches, excavations or any other work adjacent to the Site, the Contractor shall make necessary arrangements and take precautions for their support and protection at his own expense. It is the Contractor's responsibility to ensure that continuous access is maintained to all properties adjacent to the Works throughout the Contract period to the Engineer's satisfaction.

The Contractor shall be responsible at his own cost to repair and return to their previous condition items to which the Contractor's works have caused damage.

Pursuant to his contractual obligations under the Contract, the Contractor shall, whenever required or directed by the Engineer, cover up and protect the Works from weather and from damage by his own or other workmen performing subsequent operations. He shall provide all necessary dustsheets, hoardings, barriers and guard rails, waterways, etc., and clear away same at completion. The Contractor shall take all reasonable and proper steps for the protection of all places on or about the Works which may be dangerous to his workmen or any other persons or to traffic. The Contractor shall provide and maintain warning signs, warning lamps and barricades as necessary in all such places.

The Contractor shall furnish and place fresh or brackish water at his own expense for dust control when and where construction operations require it and at locations specifically instructed by the Engineer due to any adverse conditions created by the Contractor or his construction operations.

Existing roads, accesses to houses, buildings, etc., and any new roads, whether part of the Works or not, which are being used by the Contractor's construction traffic shall be kept clean and clear of all dirt, mud and material dropped from vehicles or from tyres, and any damage caused shall be repaired at the Contractor's expense. The Contractor shall provide, maintain and use as directed by the Engineer, suitable equipment, including mechanical road sweepers, solely for this purpose throughout the course of the Works.

A  
B

### 102.13 - MANAGEMENT, SAFETY AND CONTROL AND TEMPORARY DIVERSION OF TRAFFIC

The Contractor shall provide, erect and maintain such traffic signs, lamps, barriers, traffic control signals, lighting units, road markings and other such measures as may be necessary for the safety of the Works and third parties. The Contractor shall provide the Engineer with details of his overall scheme of traffic control or diversions for the entire project giving his programme of same etc. well in advance of his programmed commencement dates.

The Contractor shall, after consultation with all the concerned Local Authorities and Police prepare a scheme of traffic management for carrying out the Works. Such proposals shall be submitted to the Engineer for his approval, together with written approval/no objection certificates from the concerned authorities, not less than 30 days before the planned implementation of each proposal. The Contractor shall not commence any works affecting any public highway until all approved traffic safety measures conforming to the Engineers' prior approval have been fully implemented to the satisfaction of the Engineer. The Contractor shall maintain all signs, lamps, barriers, traffic control signals, and road markings in a clean and legible condition, and shall position, re-position, cover or remove them as required by the progress of the Works.

The Contractor shall construct temporary diversion ways wherever the construction of the Works will interrupt existing public or private roads or rights-of-way. Diversions must be constructed in advance of any interference with the existing rights-of-way, and the subsequent traffic management, safety and control shall be in accordance with the paragraphs of this Clause 102.13 and/or as directed by the Engineer.

Where traffic management schemes are shown in the Contract Drawings they are for guidance and bidding purposes only. It is solely the responsibility of the Contractor to plan and design the necessary traffic diversions in the most efficient way possible in order to enable him to complete the Works within the Contract Period, with the minimum disruption to normal traffic flow, and absolute minimum impact on the Works, third parties, and environment.

The standard of construction and lighting of diversions shall be suitable in all respects for the volume, size and speed of traffic using the existing way. The level of lighting shall be as indicated on the Drawings or as directed by the Engineer, and must satisfy the requirements of the concerned local authorities prior to being approved by the Engineer. The width and number of lanes shall be sufficient to maintain an acceptable traffic flow commensurate with existing conditions. In any case the minimum width of traffic lane shall be 3.5 metres. On dual carriageway detours the number of traffic lanes provided in each direction shall be a minimum of two.

Permanent roads used as temporary detour roads shall be signed and marked in compliance with detour road requirements whilst under detour road status. Should this road marking and signing be of a temporary nature the Contractor shall ensure that its removal will not impair the quality of the permanent Works. Under no circumstances will the Contractor be allowed to open any new carriageway for detour traffic with permanent road markings which are not in compliance with the accepted detour markings.

The minimum pavement construction of any diversion road, unless otherwise specified, shall not be less than 40mm of bituminous paving course on 150mm of primed granular road base, constructed in accordance with the requirements of Division 400 of the Specifications. Paving may be laid directly on primed subgrade only with the Engineer's prior approval. The Contractor will remain responsible for the maintenance of the pavement in a satisfactory condition for as long as the diversion is required.

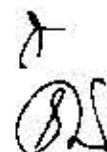

In urban areas, the traffic diversions shall be illuminated to a suitable lighting intensity as indicated on the Drawings. In rural or other areas, where no street lighting exists, all signing shall be reflectorized and all changes in direction shall be floodlit at night to an intensity approved by the Engineer.

#### **102.14 - FIRE PRECAUTIONS**

Adequate precautions shall be taken against fire throughout all the Contractor's and Sub-Contractors' operations. Quantities of flammable materials on site shall be kept to an absolute minimum, and shall be properly handled and stored. Gasoline and other flammable liquids, as well as pressurised gas tanks, shall be stored in and dispensed from safety containers; however, storage of such containers shall not be within the offices or any other buildings. Except as otherwise provided herein, the Contractor shall not permit fires to be built or open type heating devices to be used in any part of the work.

Construction practices, including cutting and welding, and protection of adjacent materials during construction shall be in accordance with good standard practices for such work. The Contractor shall provide a sufficient number of approved portable fire-extinguishers distributed about the buildings and construction site. The Contractor shall arrange for periodic inspection by the local fire authority and shall co-operate with the said authority to promptly carry out their recommendations at his own expense.

#### **102.15 - SAFETY OFFICERS**

The Contractor shall inform the Engineer in writing within two weeks of the start of the Works the names of qualified and responsible persons resident on the Site who will be undertaking the duties of Safety Officers and Safety Supervisors. A Safety Officer shall be in continuous attendance on site 24 hours a day throughout the Contract Period.

#### **102.16 - CONTRACT DRAWINGS AND DOCUMENTS**

The Works shall be executed in accordance with the Drawings and other such information as may be issued or approved by the Engineer. The Contractor will be furnished with one set of the Drawings free of charge.

#### **102.17 - SHOP DRAWINGS, WORKING DRAWINGS, OPERATIONS AND MAINTENANCE INSTRUCTIONS**

The Contractor will not be permitted to execute any kind of works at the Site unless current approved shop/working drawings are in existence. For any work or part thereof as requested, the Contractor shall supply four (4) copies of shop/working drawings for approval by the Engineer. All working drawings shall be A3 size folded to A4 size. For all such drawings, the Engineer shall return to the Contractor one (1) copy with any necessary corrections for re-submission, or marked with approval. The Contractor shall also provide the Engineer with all information, scale drawings and every assistance so that the Engineer can prepare drawings of work as executed to form a complete record of the finished work. All drawings must be prepared using a Computer Aided Drafting system approved by the Engineer.

Drawings shall be plotted by the Contractor as required by the Specifications, and diskettes/disks containing the drawings data are to be supplied to the Engineer in the approved digital format. At the end of the Contract, the Contractor shall submit to the Engineer the original computer files of all drawings previously approved with two (2) sets of prints of the same. In case of loss or destruction of any of the copies previously submitted to the Engineer for approval, the Contractor shall supply free of charge, the necessary copies so as to make three (3) complete sets of all drawings approved during construction.



The Contractor shall record the exact location of all utility apparatus excavated during the Works and shall submit drawings to the Engineer showing such information for incorporation by the Engineer into the Record Drawings. The cost of producing such drawings, either during construction or at the time of delivery of the final account (for which the original computer drawing file or drawing negative plus 3 copies of all attachments are necessary), shall be borne directly by the Contractor, and no separate payment shall be in anyway considered.

Within sixty (60) days of the date of field staking the Contractor shall submit to the Engineer for his approval the plotting of the original and final earthwork cross-sections, together with the area and volumetric earthwork computations. The Contractor's cross-section shall be on transparent cross-section sheets for print reproduction, or Computer Aided Drawing format approved by the Engineer.

On final approval of the Contractor's cross-sections, the Contractor shall give the Engineer the original transparent tracings or computer drawing file, and three (3) prints of the same along with approved volumetric earthwork computations (in A4 size and bound). If the Contractor fails or refuses to submit cross-sections within the specified time the Engineer may withhold payment for all or any part of the earthwork quantities involved. All cross-sections shall be plotted on A3 size drawing folded to A4 size

#### **102.18 - RECORD DRAWINGS**

The Contractor shall provide the Engineer with assistance to prepare accurate record drawings. These drawings shall show the Works as executed, complete with existing and finished levels (top, invert, and formation levels, plans, cross and longitudinal sections, locations of all junctions, manholes, inlets, extent of concrete bed and structures, and all things necessary to form a complete pictorial record of the finished work). Also to be shown are the exact locations with dimensions of existing and new utility ducts, cables, pipes, etc. A3 record drawings so prepared by the Engineer shall be dated and signed by the Contractor and the Engineer as being a true record of the as-built Works.

#### **102.19 - ACCOMMODATION WORKS**

The Contractor shall be responsible for making all necessary arrangements with owners and occupiers for carrying out accommodation works, including, where necessary, access onto or across private land. Where, in the opinion of the Engineer, the convenience or amenity of an owner or occupier or of the public generally is affected by the Works, the Engineer may order the Contractor to complete any accommodation work, or part of an accommodation work, with the utmost expediency and irrespective of the Contractor's overall programme for the Works.

#### **102.20 - PUBLICITY**

The Contractor or any agents or servants in his employ shall not provide any information concerning the Works for publication in the press or on radio, television or cinema screen or elsewhere without the written approval of the Employer. The Contractor, or any sub-contractor shall erect no advertisements on the Site without written approval of the Employer. Should any advertisement be erected within the Site without such prior approval the Engineer may instruct the Contractor to remove it forthwith. Should such an instruction fail to be carried out within 24 hours, the Engineer may remove the advertisement and charge the cost to the Contractor. All advertisement within the Site shall be removed within one month of the date of the Certificate of Substantial Completion of the Works, unless the Employer agrees in writing for any advertisement to remain for a further period.

7  
25

**102.21 - TIDYING THE SITE**

The Contractor shall maintain the Site in a clean and orderly condition free from accumulation of waste materials and rubbish during the entire construction period to the satisfaction of the Engineer. On completion the entire Site within the Right-of-Way is to be cleared of all construction materials and temporary buildings, etc. to the satisfaction of the Engineer.

**102.22 - SOIL INVESTIGATION**

Any information provided by the Employer about soils investigations carried out is for the Contractor's incidental information only. It is the Contractor's responsibility to check and confirm the existing ground conditions, and in particular the likelihood of encountering water during the course of sub-surface construction.

**102.23 - WORKS FREE FROM WATER**

Except where in the opinion of the Engineer, the route of the work necessitates underwater construction, the Contractor shall execute all works in the dry, and shall construct any temporary drains, water courses, pumping and other works that may be necessary for the purpose. The Contractor shall have included for the cost of all operations necessary to comply with this Clause within his bid.

**102.24 - OTHER CONTRACTORS ON SITE**

The Contractor shall extend full cooperation by way of liaison and coordination with other contractors who may be operating within the Site of the Works engaged in essential work for the Government of Sri Lanka.

AS

## 103 - MAJOR EQUIPMENT AND PLANT

### 103.1 - GENERAL

"Equipment" shall mean, where mentioned in these Specifications, all machines, tools, equipment and all necessary parts for their operation and maintenance; and also, the laboratory tools and instruments and/or equipment necessary for the proper construction of the road and the proper completion of all the Works.

The Contractor shall submit, as stipulated in the "Instructions to Bidders" a detailed list of plant and equipment, which he shall undertake to bring to the Site to carry out the Works. The list shall include for each piece of equipment, the type, size, quantity, manufacturer, model, identification number and year of manufacture. The Contractor shall supply all plant and equipment necessary for the construction of each phase of the work and it must be on the Site, inspected and approved by the Engineer prior to the commencement of the particular phase of work. Any plant or equipment or portion thereof, which becomes worn or defective shall be immediately repaired or replaced to the satisfaction of the Engineer.

### 103.2 - COMPACTING EQUIPMENT

The compaction equipment for earthwork may be towed or self-propelled and shall include a suitable combination of tamping rollers, grid rollers, segmented pad rollers, vibrating rollers, pneumatic rollers and other compaction equipment that can satisfactorily and uniformly obtain the required compaction.

#### i) Tamping or Sheepfoot Rollers

Tamping or sheepfoot rollers shall consist of metal rollers, drums, or shells surmounted by metal studs with tamping feet projecting not less than sixteen and one-half (16.5) centimetres from the surface of the roller, drum or shell. Tamping feet shall be spaced not less than fifteen (15) centimetres or more than thirty (30) centimetres measured diagonally centre to centre and the cross section area of each tamper foot, measured perpendicularly to the axis of the stud, shall be not less than twenty-five and eight-tenths (25.8) square centimetres. The weight of tamping rollers shall be such that when fully loaded, the load on each tamper foot will be determined by dividing the total weight of the roller (loaded) by the number of tamper feet in one (1) row parallel to the axis of the roller.

#### ii) Pull Type Steel Rollers

Pull-type steel rollers shall have not less than one and two-tenths (1.2) metre effective width of roller and shall be designed and constructed so that the weight per linear centimetre of roller can be varied from 70 N to at least 100 N.

#### iii) Self-propelled Steel Rollers

The power mechanism of a self-propelled roller shall be capable of propelling the roller smoothly and without jerking when starting, stopping, or reversing directions free from backlash, loose link motion, faulty steering mechanism and worn king bolts. The steering mechanism shall have no lost motion, shall operate readily and permit the roller to be directed on the alignment desired. The faces of all rollers shall be smooth and free from defects, which mark the finished road surface. Rollers shall be equipped with water tanks and sprinkling devices to wet the roller to prevent adherence of the placed material.

A  
BLS

Two-axle tandem steel rollers shall weigh not less than eight (8) tonnes or more than twelve (12) tonnes and shall have a weight per centimetre width of roll between 35kg and 70kg.

Three-axle tandem steel rollers shall weigh not less than eleven (11) tons. A three-axle tandem roller shall be so constructed that the rollers, when locked in position for all treads to be in one plane, are held with a rigidity which will satisfy the following test: under full load:

a) with the weight of the roller supported on the central roller, the tread of the central roller shall not be more than three (3) millimetres above the plane tangent to the tread of the end rollers.

b) with the weight of the roller supported on the end rollers, the tread of the central roller shall not be more than six (6) millimetres below the plane tangent to the treads of the end rollers.

#### iv) Trench Rollers

Trench rollers shall be of approved type weighing not less than fifty-three and six tenths (53.60) kilograms per centimetre of width and shall be equipped with water and sprinkling devices that shall be used for wetting the roller to prevent adherence of the placed material.

#### v) Pneumatic-tyred Rollers

The tyres on the front and rear axles of pneumatic-tyred rollers shall have wide smooth treads and shall be staggered to provide complete coverage of the entire area over which the roller travels. The tyres shall be inflated to a pressure that has been approved by the Engineer, and the pressure shall be reasonably uniform in all tyres. The Contractor shall provide a suitable gauge, having been approved by the Engineer, for determining air pressure in the tyres.

Light self-propelled pneumatic-tyred rollers shall be so constructed so that they may be loaded to provide a gross weight of at least forty (40) kilograms per centimetre of width of tyre tread.

Heavy self-propelled pneumatic-tyred rollers shall be constructed so that they can be loaded to provide a gross weight of not less than twenty five (25) tonnes, and they shall have tyre pressures of 6 - 6.3 kg/cm<sup>2</sup>.

#### vi) Vibration Compactors

Equipment using the principle of vibration as a tamping force shall be in good mechanical condition and shall be capable of transmitting forceful vibrations or impacts to the various materials placed in construction. The equipment may be the roller or pad type or a combination of roller and pad type. Vibrating compactors shall be of the type and force approved by the Engineer.

### 103.3 - HAULING AND WEIGHING EQUIPMENT

#### i) Hauling Equipment

Hauling equipment for aggregate shall consist of vehicles having dump bodies suitable for dumping materials in a windrow or in spreader boxes. The bodies shall be so constructed that their volume measurement can be accurately determined. They shall be so constructed and maintained to prevent loss of materials during hauling operations.

The equipment shall be provided with dump controls that can be operated from the driver's seat. The bodies of hauling equipment using public roads shall be fitted with tarpaulins to prevent the nuisance of spillage.

### **ii) Weighing Equipment**

Weighing equipment for truck-hauled material shall consist of accurate and reliable platform scales and they shall be accurate to one percent throughout the range of use. The scale shall have a platform of adequate length to weigh in one operation the longest truck or truck-trailer combination that will be used for the Works. Scales shall be inspected and sealed or certified by an approved scale company, as often as the Engineer deems necessary to ensure their accuracy. The seal or certification shall show the date of the inspection. Where no approved scale company exists, or at the option of the Engineer, the Contractor shall check and adjust the scale in the presence of the Engineer in the method recommended by the manufacturer and/or approved by the Engineer. It is the Contractor's responsibility to have sufficient standard test weights for each scale on the Site.

The Engineer, as often as he deems it necessary, shall direct the Contractor to check and adjust any scale on site to ensure its accuracy. The Contractor shall, when directed by the Engineer, make weight comparisons with other permanently located scales that meet with the approval of the Engineer. These weight comparisons shall be for the purpose of providing information on the performance of the Contractor's scale and will not be used as a basis for adjusting the scale. The approaches to the scale platform shall be maintained by the Contractor to the satisfaction of the Engineer. The Contractor shall furnish a suitable weather tight building to enclose the indicating mechanism and shall have adequate lighting for the scale operator's use. The Contractor shall have on hand not less than ten (10) twenty-five (25) kilogram weights for testing the scale

### **iii) Controlled Water Distribution Equipment**

Equipment for distribution of water shall consist of distributors or tanks equipped with spray bars and, when required, pumps to operate under pressure. The pumps shall be of sufficient capacity to provide uniform and adequate distribution and shall be mounted on pneumatic-tyred trailers pulled by pneumatic-tyred equipment. The minimum capacity of any tank shall be four (4) cubic metres where applicable. The distributor equipment shall be constructed to permit accurate and uniform distribution of the desired quantities of water per unit of surface area. The control valves shall be constructed to permit full closing and to prevent leakage. The water control valves shall be constructed such as to be operable from the driver's seat, or provisions shall be made for an additional operator to operate the control valves while the equipment is travelling at the proper speed for distribution.

## **103.4 - MAIN PLANT FOR BITUMINOUS PAVING WORKS**

### **i) Equipment for Heating Bituminous Materials**

Equipment for heating bituminous materials shall be of adequate capacity to heat the material properly by circulating the bituminous material around the system of heated coils or pipes, or by circulating the bituminous material through a system of coils or pipes enclosed in a heated jacket, or other approved means. The heating device shall be constructed so that it will prevent the direct flame from a burner from striking the surface of the coils, pipes or jackets through which the bituminous material is circulated. The heating device shall not be operated in a manner that will injure the bituminous material. Tankers or trucks received on the Site which have defective coils, or from which the coils have been removed, will be rejected by the Engineer unless some satisfactory auxiliary means can be provided by the Contractor for the heating of the bituminous material without the introduction of moisture. The use of any

8  
02



equipment for the agitation of bituminous material to aid in heating will be prohibited if it injures or in any way changes the characteristics of the bituminous material or introduces free steam or moisture into the tank containing the bituminous material.

Tanker or truck connections for transferring bituminous material from tankers to distributors, supply tanks, or storage tanks shall be constructed so that they cannot be used for any other purpose. The use of a tanker or truck connection or any other equipment by means of which free steam can be introduced directly into the bituminous material as a means of agitation or auxiliary heating is prohibited.

#### **ii) Bitumen Distributor**

Equipment for the distribution of bituminous materials shall be fitted with the following appliances or devices:

- tachometers,
- pressure gauge,
- adjustable length spray bars,
- separate power unit and pump on distributing system,
- heating coils and burner,
- thermometer well and accurate thermometer,
- measuring sticks,
- quick opening gate in dome.

All distributors and supply tanks shall be mounted on dependable motor trucks or trailers equipped with pneumatic tyres. The units shall be so designed to ensure that no rutting or other injury to the road surface will result. The distributor shall have pneumatic tyres of such width and number that the load produced on the road surface shall not exceed one hundred and ten (110) kilograms per linear centimetre of the width. They will be sufficiently powered to maintain the desired speed of the equipment during operation.

The manometer designating the speed of the truck shall be a separate operating unit attached to the truck equipped with a larger gauge approximately fourteen (14) centimetres in diameter and graduated in units so that the speed of the truck can be determined within limits of approximately three (3) metres per minute or equivalent thereto. The gauge shall be so located that it can be easily read at all times by the driver of the distributor.

The distributor shall be equipped with either a tachometer, calibrated to indicate revolutions per minute, attached to the pump shaft or a pressure gauge calibrated to indicate kilograms per square centimetre placed in the distributing system, by which the flow of bitumen may be regulated.

The spray bars shall be constructed to permit adjustment for length in increments of thirty (30) centimetres for any length up to seven (7) metres, to permit vertical adjustment of all nozzles to the desired height above the road surface conforming to the roadway crown, and to permit lateral shifting of the entire spray bar during operation. The spray bars and nozzles shall be constructed to prevent clogging of the nozzle during the intermittent operation and to provide positive and intermediate cut-off when distribution of oil ceases, thus preventing dripping of oil from the bar.

The power unit and pump distribution system shall have a capacity of not less than nine hundred fifty (950) litres per minute. Also it must be equipped with a by-pass into the supply tank and be capable of distributing a uniform and constant flow of bituminous material through all nozzles at a pressure between one and one quarter (1.25) and three and one-half (3.5) kilograms per square centimetre.

A  
BS

The entire distributor assembly shall be so constructed and operated as to ensure accurate distribution of bituminous material at rates of from two-tenths (0.2) to seven and half (7.5) litres per square metre with uniform pressure, and with an allowable variation from any specified rate not to exceed one-tenth (0.1) litres per square metre. Minimum capacity of the distributor shall be four thousand (4,000) litres.

### iii) Calibration and Checking of Distributors

All distributors shall be calibrated and checked before being used for the Works. The calibration of the tank will be performed by the Contractor in the presence of the Engineer by the method prescribed by the manufacturer and/or as directed by the Engineer. The operation of the distributor will be checked by the Engineer the first time it is used and when he deems it necessary thereafter. When the operation is subsequently found to be satisfactory, a new certificate will be issued.

### iv) Stationary Mixing Plants

Stationary mixing plants shall consist of measuring and proportioning equipment and mixing equipment. They shall also include dryers when aggregates are furnished that contain moisture in excess of the amounts permitted for mixing. The measuring and proportioning equipment shall consist of a system of hoppers and scales designed for proportioning and measuring by batch weights or of continuous flow equipment so designed and operated that the flow of materials can be accurately and continuously regulated, and so arranged to permit easy and accurate checking of the rate of flow on a weight basis. For continuous flow mixing, the proportioning equipment may be at the stockpile site so that the individual aggregate may be blended prior to entering the drier. The drier shall be capable of drying and heating the mineral aggregates to specification requirements. The proportioning devices for the bituminous materials and aggregates shall be so synchronised that proper proportioning will be obtained at all times. The design of the mixing chambers shall provide adjustment to permit a mixing period of sufficient duration to produce a thorough and uniform mix. The approval of and continued use of a stationary plant shall be contingent upon its ability to proportion and mix satisfactorily the several materials in adequate quantity for the proper progress of the work.

### v) Hot Mix Plants

All equipment shall meet the approval of the Engineer, shall be kept in good working condition, shall meet the requirements herein specified, and shall be of sufficient capacity to produce and process not less than eighty (80) tons of mixed material per hour. All plants used by the Contractor for the preparation of bituminous mixes and (Plant Mix) prepared mixes shall conform to all the requirements of these Specifications except that scale requirements shall apply only where weight proportioning is used. Additionally, batch mixing plants and continuous plants shall conform to the special requirements of these specifications.

In addition the hot mix plant shall be provided with the following:-

- (i) Covered protected ladders or stairways with secure hand rails in adequate number which shall be placed at all points required for accessibility to all operations.
- (ii) Covering devices for pulleys, belts and drive mechanisms and other moving parts.
- (iii) Ample and unobstructed space on the mixing platform.

✓  
②

- (iv) A clear and unobstructed passage at all times in and around the tipper loading space which shall be kept free from drippings from the mixing platform.
- (vi) Insulated flexible pipe connections to carry hot bitumen from the heated storage tanks to the mixer.

#### **vi) Requirements for all Plants**

##### **Uniformity**

The plants shall be so designed, co-ordinated and operated to produce a uniform mixture.

##### **Scales**

Scales for any weight box or hopper may be of either the beam or springless dial type and shall be of a standard make and design, accurate to one (1) percent of the maximum load that may be required.

When scales are of the beam type, there shall be a separate beam for each size of aggregate. There shall be provided a "Tell-tale Dial" that will start to function when the load being applied is within fifty (50) kilograms of that desired. Sufficient vertical movement shall be provided for the beams to permit the tell-tale dial to function properly. Each beam shall have a locking device so designed and located that the beam can easily be suspended or thrown into action.

Dial scales shall be springless, of a standard make, and of such size that the numerals on the dial can be read at a distance of at least eight (8) metres. The dial shall be of the compounding type having full complement of index. Pointers so placed as to give excessive parallax errors shall not be used. The scales shall be substantially constructed, and those that easily get out of adjustment shall be replaced with other makes when so ordered. All dials shall be so located as to be plainly visible to the operator at all times.

Scales shall be inspected and sealed or certified as often as the Engineer may deem necessary to ensure their continued accuracy. The initial inspection shall be done by an approved scale company, or by the Contractor in the presence of the Engineer, by the method prescribed by the manufacturer and/or as directed by the Engineer. The Contractor shall have on hand not less than ten (10) twenty-five (25) kilograms weights for testing the scales.

##### **Equipment for the Preparation of Bituminous Material**

Tanks for the storage of bituminous material shall be equipped to heat and hold the material at the required temperature. The heating shall be accomplished by steam coils, electric hot coils, or other approved means so that the flame shall not be in contact with the tank.

The circulating system for the bituminous material shall be designed to ensure proper and continuous circulation during the operating period. Provision shall be made for measuring and sampling storage tanks. Storage tanks shall have sufficient capacity to provide for continuous operation. The storage tanks shall be calibrated and equipped with a device whereby the Engineer may determine the amount of asphalt on hand at any time.

##### **Feeder for Drier**

The plant shall be provided with accurate mechanical means for uniformly feeding the aggregate into the drier so that uniform production and uniform temperature will be obtained.

8  
82



A separate mechanical feeder equipped with an adjustable gate opening shall be provided for each individual aggregate being combined to produce the total aggregate. The feeders and gate shall be so constructed and equipped that a continuous and uniform flow of each material will be ensured. They shall also be installed in such a manner as to be readily accessible for calibrating at all times.

#### **Drier**

The plant shall include a drier(s) that continuously agitates the aggregate during the heating and drying process. The drier shall be capable of drying and heating the mineral aggregate to specification requirements. The burners shall be of such capacity, and they shall be so constructed and operated that complete combustion of the fuel is obtained.

#### **Screens**

Plant screens' capable of screening all aggregates to the specified sizes and proportions and having normal capacities in excess of the full capacity of the mixer, shall be provided.

#### **Bins**

The plant shall include storage bins (cold and hot) of sufficient capacity to supply the mixer when it is operating at full capacity. Bins shall be arranged to ensure separate and adequate storage of appropriate fractions of the mineral aggregates. Separate dry storage shall be provided for Portland cement, hydrated lime, or other similar material when used and the plant shall be equipped to feed such material into the mixer. Each bin shall be provided with overflow pipes, of such size and at such location as to prevent backing up of material into other compartments or bins. Each compartment shall be provided with its individual outlet gate, constructed so that when closed there shall be no leakage. The gates shall cut off quickly and completely. Bins shall be so constructed that samples can be readily obtained. Bins shall be equipped with adequate tell-tale devices to indicate the position of the aggregates in the bins at the lower quarter point. The minimum number of bins shall include at least one bin for each different stockpile of material being used. Intermixing of material from different stockpiles in one bin or on the ground shall not be permitted.

#### **Bituminous Control Unit**

Satisfactory means shall be provided, by weighing or metering, to obtain the proper amount of bituminous material in the mix within the tolerance specified. Means shall be provided for checking the quantity or rate of flow of bituminous material into the mixer. Suitable means shall be provided for maintaining the specified temperature of the bituminous material in the pipelines, meters, weight buckets, and spray bars.

#### **Thermometric Equipment**

An armoured thermometer of adequate range in temperature reading shall be fixed in the bituminous feed line at a suitable location near the charging valve at the mixer unit. The plant shall also be equipped with either an approved dial-scale mercury-actuated thermometer, an electric pyrometer, or other approved thermometric instrument so placed at the discharge chute of the drier as to register automatically or indicate the temperature of the heated aggregates.

All plants whether continuous or batch type shall be equipped with two recording thermometers. These instruments shall be provided with dust-proof cases, long leads, and automatic recording mechanism capable of recording the desired temperature for a period of

A  
95

twenty-four (24) hours on a chart not less than twenty (20) centimetres in diameter, or on a continuous sheet. The chart for either type shall be graduated in hours, minutes, and degrees of temperature. The maximum time graduation shall be fifteen (15) minutes and the maximum temperature graduation shall be five (5) degrees centigrade. Hours on the chart shall be designated as a.m. or p.m.

The temperature recording thermometers shall be installed on points or a framework, separate from the plant, to eliminate plant vibration.

They shall be located in a manner to provide easy access to the case and chart. The bulb of one instrument shall be installed in the hot asphalt line as close as is practicable to the spray bar discharge, the bulb of the second recording thermometer shall be installed in the hot aggregate bin, which contains the fine aggregate. The bulb shall be located where the hot materials will flow over it during the proportioning operation and shall not be located near the corners of the bin or at locations where the material will collect or pack around it. The Engineer reserves the right to pass judgement upon the efficiency of thermometric instruments.

#### **Control of Mixing Time**

The plant shall be equipped with positive means to govern the time of mixing and to maintain a constant time unless changed by order of the Engineer.

#### **Dust Collectors**

The plant shall be equipped with a dust collector constructed to waste or return uniformly to the hot elevator all or any part of the material collected, as desired.

#### **Safety Requirements**

Adequate and safe stairways to the mixer platform and sampling points shall be provided and guarded ladders to other points shall be placed at all points where accessibility to plant operation is required. Accessibility to the top of truck bodies shall be provided by a platform or other suitable device to enable the Engineer to obtain sampling and mixture temperature data. A hoist or pulley system shall be provided to raise scale calibration equipment, sampling equipment and other similar equipment from the ground to the mixer platform.

All gears, pulleys, chains, sprockets, and other dangerous moving parts shall be thoroughly guarded and protected. Ample and unobstructed space shall be provided on the mixing platform. A clear and unobstructed passage shall be maintained at all times in and around the truck loading area. The area shall be kept free from droppings from the mixing platform.

#### **vii) Special Requirements for Batching Plants Using Weigh Box or Hopper**

The equipment shall include a means for accurately weighing each size of aggregate in a weigh box or hopper suspended on scales and of ample size to hold a full batch without hand raking or running over. The gate shall close tightly so that no material is allowed to leak into the mixer while the batch is being weighed. Asphalt plants shall meet requirements in accordance with ASTM D995 & ASTM D290.

A  
DS

### **Bituminous Control**

The equipment used to measure the bituminous material shall be accurate to plus minus five-tenths (0.5) percent. The bituminous material bucket shall be a non-tilting type with a loose sheet metal cover. The length of the discharge opening or spray bar shall be not less than three quarters (3/4) the length of the mixer and it shall discharge directly into the mixer. The bituminous material bucket, its discharge valve or valves and spray bar shall be adequately heated. Steam jackets, if used, shall be efficiently drained and all connections shall be so constructed that they will not interfere with the efficient operation of the bituminous scales. The capacity of the bituminous material bucket shall be at least fifteen (15) percent in excess of the weight of bituminous material required in any batch. The plant shall have an adequately heated quick-acting, non-drip, charging valve located directly over the bituminous material bucket.

The indicator dial shall have a capacity of at least fifteen (15) percent in excess of the quantity of bituminous material used in a batch.

The dial shall be in full view of the mixer operator. The flow of bituminous material shall be automatically controlled so that it will begin when the dry mixing period is over and all of the bituminous material required for one batch will be discharged in not more than fifteen (15) seconds after the flow has started. The section of the bituminous line between the charging valve and the spray bar shall be provided with a valve and outlet for checking the metering device.

### **Mixer**

The batch mixer shall be an approved type capable of producing uniform mixture. If not enclosed, the mixer box shall be equipped with a dust hood to prevent loss of dust. The clearance of blades from all fixed and moving parts shall not exceed 25 millimetres. Unless the maximum diameter of the aggregate in the mix exceeds 30 millimetres, in which case the clearance shall not exceed 38 millimetres.

### **Control of Mixing Time**

The mixer shall be equipped with an accurate time lock to control the operations of a complete mixing cycle. It shall lock the weigh box gate after the charging of the mixer until the closing of the mixer at the completion of the cycle. It shall lock the bituminous material bucket throughout the dry mixing period and shall lock the mixer gate throughout the dry and wet mixing periods. The dry mixing period is defined as the interval of the time between the opening of the weigh box gate and the start of introduction of bituminous material. The wet mixing period is the interval of time between the start of introduction of bituminous material and the opening of the mixer gate. The control of the timing shall be flexible and capable of being set at intervals as necessary for mixing time throughout the total mixing cycle. A mechanical batch counter shall be installed as a part of the timing device and shall be so designed as to register only completely mixed batches.

### **Automation and Recording of Bituminous Concrete Plants**

The plants shall be equipped with an automatic mass measuring cycling and monitoring system approved by the Engineer. Recording equipment shall monitor the batching sequence of each component of the mixture and produce a printed record of these operations. For each day's production the Engineer shall be provided with a clear, legible copy of the recording. There should be provisions so that scales may not be manually manipulated during the printing process.

A  
Q1

## **viii) Special Requirements for Continuous Mixing Plants**

### **Aggregate Proportioning**

The plant shall include means of accurately proportioning each size of aggregate. The plant shall have a feeder mounted under each compartment bin. Each compartment bin shall have an accurately controlled individual gate to form an orifice for volumetrically measuring the material drawn from each compartment. The feeding orifice shall be rectangular with one (1) dimension adjustable by positive mechanical means and provided with a lock. Indicators shall be provided for each gate to show the respective gate opening in centimetres.

### **Weight Calibration of Aggregate Feed**

The plant shall include a means for calibration of gate opening by weighing test samples. Provisions shall be made so that materials fed out of individual orifices may be bypassed to individual test boxes. The plant shall be equipped to conveniently handle individual test samples weighing not less than one hundred (100) kilograms. Accurate scales shall be provided by the Contractor to weigh test samples.

### **Weight Calibration of Bituminous Material**

The bituminous discharge line shall be equipped with suitable valves and a bypass so that the asphalt pump meter may be readily calibrated. For each change of stockpiles, the plant shall be recalibrated.

### **Synchronisation of Aggregate Feed and Bituminous Material Feed**

Satisfactory means shall be provided to afford positive interlocking control between the flow of aggregate from the bins and the flow of bituminous material from the meter or other proportioning device. This control shall be accomplished by interlocking mechanical means or by any other positive method satisfactory to the Engineer.

### **Mixer**

The plant shall include a continuous mixer of an approved type, adequately heated and capable of producing a uniform mixture. It shall be equipped with a discharge hopper with dump gates which will permit rapid and complete discharge of the mixture. The paddles shall be adjustable for angular position on the shaft and reversible to retard the flow of the mix. The mixer shall have a manufacturer's plate giving the net volumetric contents of the mixer at the several heights inscribed on a permanent gauge. Charts shall be provided showing the rate of feed of the aggregate per minute for the aggregate being used.

### **Bituminous Paver**

Bituminous pavers shall be self-contained, power propelled units, provided with automatically controlled activated screed or strike-off assembly, heated if necessary, and capable of spreading and finishing courses of bituminous plant mix material in lane widths applicable to the specified typical section and thickness shown on the plans. Pavers used for shoulders and similar construction shall be capable of spreading and finishing courses of bituminous plant mix material in the widths shown on the plans. Pavers shall be capable of laying one hundred (100) tonnes per hour.



The machines shall employ mechanical devices such as equalising runners, straight-edge runners, evener arms, or other compensating devices to adjust the grade and confine the edges of the mixer to true lines without the use of stationary side forms.

The paver shall be equipped with a distribution system to place the mixture uniformly in front of the screed.

The screed or strike-off assembly shall effectively produce a finished surface of the required evenness and texture without tearing, shoving or gouging the mixture.

The paver shall be capable of being operated, when laying mixture, at forward speed consistent with satisfactory laying of the mixture.

The automatic controls for the paver shall be an automatic linkage arrangement so that through the process of automatically adjusting the screed, the thickness of asphaltic mixtures can be placed and finished to predetermined grade and a uniform crown or cross-section.

Manually controlled bituminous pavers may be used only with the written consent of the Engineer. A manually controlled bituminous paver shall be of the self-propelled type with spread and strike-off facilities designed to spread the mixture in such a manner that no supplemental shaping will be required. It shall be capable of spreading the mixture evenly, with uniform density, without segregation and shall strike off true to the cross-section screeds. It must be constructed so as not to follow minor irregularities in the base and must be readily adjustable to control accurately the depth spread.

No manually operated bituminous paver shall be delivered to the Site prior to its approval by the Engineer.

A self-propelled aggregate spreader shall be of approved design supported by at least four (4) wheels equipped with pneumatic tyres on two (2) axles. The aggregate spreader shall be equipped with a means of applying the larger cover coat material to the surface ahead of the smaller cover coat material and with positive control so that the required amount of material will be deposited uniformly over the full width of the bituminous material. Other types of aggregate spreaders may be used provided they accomplish equivalent results and/or are approved by the Engineer.

### **103.5 Measurement & Payment**

#### **Mobilization and Demobilization of Contractor's Facilities and Plant/Equipment**

The Contractor will be paid for the mobilization of major items of Plant/Equipment. Major items of Plant/Equipment are defined as those that cost more than 1% of the Contract Price with an overall maximum of 5% of the Contract Price.

Payment for temporary installation and facilities, including offices, site laboratory, accommodation, workshops, quarries, borrow pits, batching and blending plants, etc. shall be made upon their satisfactory completion.

50% of the item will be paid on arrival and erection on the site of the specified items of Plant/Equipment. The remainder will be paid on confirmation by the Engineer that the output of the Plant/Equipment complies with the requirements of the specification.

↑  
DS



## 104 - GENERAL CLIMATE PREVAILING IN SRI LANKA

The information below is given only as a general outline description of the climate of Sri Lanka. The Contractor will be assumed to have made his own detailed investigations of the climatic conditions occurring in and around the Site, and taken into consideration the same when preparing his Bid.

Sri Lanka is a tropical island in the Indian Ocean just north of the Equator and east of the southern tip of India.

The island has a marked variation in climate due to its central highland region being surrounded by an extensive lowland area.

The regional differences in temperature are due to altitude and not latitude. Slight monthly differences in temperature occur, mainly due to the seasonal movement of the sun, some modifying influences are also caused by rainfall. In the lowlands, the mean annual temperature is 27°C with a mean daily range of 6°C, in the central highlands with altitudes up to 2,400m a cooler climate is experienced

The relative humidity varies generally from 70% by day to 90% at night.

Annual rainfall varies from 2,500mm to over 5,000mm in the southwest of the island, while in the northwest and southeast the annual averages are usually less than 1,250mm. The project is sited in the southwest quarter of the island.

Between May and September the winds at mean sea level are from the southwest, and this period is known as the Southwest Monsoon season. From December to February, the winds at mean sea level are from the Northeast and this period is known as the Northeast Monsoon season. The two two-month periods between March-April and October-November between the monsoon seasons are referred to as the inter monsoon periods. During these latter periods, due to large scale convective activity over the Inter Tropical Convergence Zone, rains occur.

## 105 - CARE OF THE ENVIRONMENT

The Contractor shall take all reasonable precautions, whether specified in the Contract or not to prevent damage to the natural environment occurring as a result of the execution of the Works. The Contractor will be required to prepare Environmental Management Plans (EMP) for the North and South Sections and submit to the Engineer for approval prior to work commencing on site.

A draft EMP is given below for guidance

### 105.1 - DRAFT ENVIRONMENTAL MANAGEMENT PLAN

The Environmental Management Plan (EMP) outlines the actions necessary for the contractor to comply with current and future environmental regulations during the construction.

The environmental management plan (EMP) therefore;

- Provides the overall management guidelines;
- Enables accurate assessment and control of significant impacts;
- Ensures that management undertakings made in the PEIA and Project Design Document are appropriately addressed.

8  
BS

In addition, ongoing monitoring is necessary to ensure that all measures undertaken are effective and meet environmental requirements in regards to water quality, dust, noise levels, safety, freshwater and terrestrial flora and fauna.

### Action Plan 1 – Air Quality

#### Objectives:

- To preserve air quality on project site.
- To implement dust control measures in accordance with best practice.

#### Tasks

##### Before Construction:

- Dust control measures to be formulated in accordance with Ambient Air Quality Regulations, 1994.
- Water for dampening would be drawn from appropriate sources water tankers with sprinkler.

##### During Construction:

- Prevent any burning of litter, green waste, or used construction material on site.
- Dust control to be achieved by spraying water on unsealed road portions as required.

##### Decommissioning:

- No special dust control measures required other than implementation of effective rehabilitation measures.

#### Monitoring

- Regular visual inspection of project machinery to ensure equipment condition and maintenance is not affecting air quality levels.
- Ongoing analysis monitoring with sample collection and analysis on 6-monthly intervals before and during construction.
- Provide full time supervision with reporting on a daily basis (North and South Sections)

#### Deliverables/Compliance Criteria

Dust levels not to exceed the permissible limits given in Ambient Air Quality Regulations, 1994.

#### Corrective Action

- Improve road and project vehicle maintenance.
- Reduce vehicle speed.
- Improve method of construction procedures.

### Action Plan 2 – Handling, Storage and Disposal of Waste and Hazardous Materials

#### Objectives

To ensure that there is no impact from the handling, storage and disposal of wastes and hazardous substances (includes oil) within the project area.

## Tasks

### Before Construction:

Ensure hazardous substances and wastes have been allocated safe and secure storage areas at the construction camp or project site office.

### During Construction:

- Clearly defined areas for storage of tyres, lead-acid batteries, inert solids, waste oil, septic tanks, and hazardous wastes.
- Clearly defined areas for storage of any hazardous substances used at the project site office, depot, vehicle fueling station, fuel tanks etc.
- Construct and maintain a bund for waste oil storage
- If required, construct and maintain septic system at the construction camp according to the Guidance of Local Authority of the respective area or otherwise connect to existing sewer line.
- Ensure correct labeling and adequate separation between different types of hazardous materials.

### Decommissioning:

- Remove all hazardous wastes from the depot and project site.
- Remove all storage tanks such as fuels and waste oils from the depot & project site.
- Disconnect and desludge septic tanks and fill with sand.

## Monitoring

Conduct weekly reviews of waste and hazardous goods management.

## Deliverables/Compliance Criteria

- Ensure septic tanks are designed to meet criteria according to CEA/local authority or toilet facilities are properly connected to existing sewer lines.
- All storage in accordance with CEA/local authority requirements
- Ensure hazardous substances are transported in accordance with the CEA/local authority requirements.

## Corrective Action

- Comprehensive maintenance program for storage and associated pipe work around dangerous substance storage.
- Formulate an Emergency Response Plan.

## Action Plan 3 – Water Quality and Ecosystem Monitoring

### Objectives

- To continuously review water quality data to determine the impact on water quality of the construction.
- To protect the environmental values of an aquatic ecosystems of the project area.
- To comply with all relevant statutory requirements.

A  
BN

## Tasks

### Before Construction:

- Review hydrological data.
- Identify suitable sites and analytical parameters for water quality monitoring.
- Determine biological indicators and monitoring requirements to satisfy regulatory reporting requirements and design appropriate monitoring systems.
- Determine validity of analytical suite and/or monitoring frequency.

### During Construction:

- Monitor construction to ensure minimum disturbance to waterways.
- Construct water management system as designed to stabilise disturbed areas.
- Manage water quality to ensure compliance criteria are met.
- Control point source contamination from on-site and off-site sources.

### Decommissioning:

- Ensure access to water quality monitoring sites is maintained.
- Monitor decommissioning activity to ensure minimum disturbance to waterways.
- Remove or secure safely any material, which could cause further contamination.
- Review requirements for ongoing monitoring, determine what monitoring facilities and access must be retained during construction phase and compliance criteria satisfied.
- Decommission, remove and/or rehabilitate all structures, facilities and monitoring facilities - excluding ongoing monitoring facilities.

## Monitoring

- Undertake baseline surface water quality monitoring at identified sites (under specific monitoring strategies).
- Continue surface quality monitoring; during operating phase adapt frequency and/or analytical parameters monitored where required by regulatory authorities and/or on the basis of analytical data obtained.
- Monitor rate of sedimentation at strategic points along the rivers using marked stakes.
- Event monitor stabilised disturbed areas and suspended solids in sedimentation basin during/immediately following significant rainfall events.
- Continue selected monitoring until stable, environmentally acceptable conditions are evident.
- Continue surface quality monitoring for a period to be determined following decommissioning.

## Deliverables/Compliance Criteria

- Adapt compliance criteria as required by regulatory authorities.
- Water quality to comply with appropriate guidelines, taking into account site-specific factors.
- Report water quality trends to operational/environmental staff.
- Waste discharges from on and off-site sources meet regulatory receiving water quality standards.
- Water quality indicators will not exceed appropriate accepted guidelines as a consequence of construction or operation.

### Corrective Action

- Where impact is identified, recommend corrective changes to be made.
- Where no impact is identified, recommend appropriate changes to the monitoring program to reduce frequency and/or parameters without compromising integrity of program.
- Modify management or site activities as necessary to meet/comply with stated regulations.

### Action Plan 4 – Noise and Vibration Control

#### Objectives

To implement noise and vibration control measures in accordance with best practice.

#### Tasks

##### During Construction:

- Trucks and other engine driven equipment at the project site will be fitted with high efficiency mufflers and retarders where necessary to avoid causing excessive noise.
- Equipment will be maintained and attended to promptly to avoid loose or rattling covers, work bearings and broken equipment.
- Where appropriate, mechanical equipment will be located on mounts designed to isolate structure-borne vibration and noise.
- Noise control equipment will be inspected in accordance with manufacturers' recommendations, or as may be otherwise reasonably required, and defects will be repaired promptly.

##### Decommissioning:

No special noise measures.

#### Monitoring

- Baseline pre-construction noise monitoring close to villages or nearest residences.
- Noise monitoring to be carried out at the commencement of construction and operation from nearest dwellings during critical early morning and evening hours or upon receipt of complaints.
- Regular visual and aural inspection of machinery to ensure equipment condition and maintenance is not affecting noise levels.
- Ongoing noise and vibration monitoring throughout operation period to regulate effect of abatement measures.

#### Deliverables/Compliance Criteria

- Noise levels not to exceed standards stated in Noise Regulations of Sri Lanka – National Environmental (Noise Control) Regulations, No.1, 1996, and interim standard for vibration dated 4 July 2002.
- Vibration levels of road not to exceed 2mm/s at any time.

A  
B2



### **Corrective Action**

- Improve noise attenuation of project machinery.
- Construction of noise barriers at strategic locations to the nearest receptors.
- Monitor noise (am/pm) from nearest residences and any complainant's dwelling.
- Reassess permitted noise level.

### **Action Plan 5 – Litter Control**

#### **Objectives**

To ensure the project site is clean, tidy and free of litter.

#### **Tasks**

##### **During Construction:**

- Project staff to practice reduce, reuse, recycle and dispose of litter in that order of preference on site.
- Adequate signage of litter prevention and bin locations to be in a visible position for project staff, visitors and other authorized personnel.
- Prohibit dumping of litter into adjacent streams and rivers.
- Periodically empty litter bins.

##### **Decommissioning:**

- Remove all temporary litter signage at completion of construction.
- Remove all litter receptacles from the project site

#### **Monitoring:**

Daily inspection of project site housekeeping by the contractor.

#### **Deliverables/Compliance Criteria**

- Ensures that all litter is disposed off-site through existing solid waste disposal channels.
- Litter free and environmental friendly project site.

#### **Corrective Action**

- Litter receptacles are to be cleaned daily by designated staff
- Educate and train project staff on proper litter disposal methods.

### **Action Plan 6 – Erosion Control**

#### **Objectives**

- To minimise disturbance of existing natural vegetation and exposed earth surfaces as a result of construction and operational activities
- To mitigate any effect of the discharge of water containing silt laden soil into rivers, streams and adjacent land.

7  
B2

## Tasks

### Before Construction:

- Carry out a vegetation survey and record species of conservation significance, any environmentally and culturally significant areas.
- With assistance of the Engineer, assess the need to install drains, silt traps and silt ponds on areas likely to discharge silt-laden water into rivers or nearby streams and land.
- Silt retention ponds to be designed according to its retention period and method of operation.

### During Construction:

- Construct all drains, erosion protection and sediment control measures to minimise erosion through the Engineer.
- Silt retention ponds will be designed to have a retention volume of at least 1% of the contributing catchment area multiplied by a depth of 2 metres. The length to width ratio shall be 2:1
- Ponds to be cleaned each time retained sediment reaches a depth of 1 metre.
- All drains should empty into silt traps or ponds prior to any discharge to any waterway.
- Material trapped in the pond to be periodically cleared and disposed off at waste disposal area.

### Decommissioning:

- Remove all temporary infrastructure and rehabilitate during the dry season.
- Maintain erosion and sedimentation controls until vegetation establishment.
- Erosion control and sediment collection structures removed after rehabilitation to ensure minimum erosion.
- Supplement topsoil with direct seeding of grasses or other vegetation cover native to the area
- Maintain erosion control structures in areas where vegetation is being established.

## Monitoring

- Monitor activities to ensure progressive rehabilitation (and use of topsoil) as soon as possible.
- Check erosion following each significant rainfall event and institute remedial measures as required.
- Annual assessment (species density and diversity) of effectiveness of re-vegetation programs.

## Deliverables/Compliance Criteria

- Erosion in drainage lines will not create excessive disturbance to stream and river sedimentation
- All disturbed areas will be rehabilitated to stable, self-sustaining biological communities that is compatible with the existing surrounding.

## Corrective Action

Undertake additional erosion control and re-vegetation measures as required.

↑  
DS

## Action Plan 7 – Occupational Health and Safety (OHS)

### Objectives

To put into place a system to manage health and safety of the project staff and the general public in accordance with the Labour Act of Sri Lanka.

### Tasks

#### Before Construction:

- Familiarise staff with requirements of Industrial Safety of the Labour Act.
- Audit current status of contractor equipment, procedures and staff competence.
- Establish relationship with OHS inspectorate at Department of Labour.
- Formulate strategy for remedial action.
- Appoint trained safety officer.
- Provide First Aid Kit and training.
- Form an OHS committee and formulate a OHS Management System if contractor does not have an existing one.

#### During Construction:

Instruct project staff the need to adhere to the requirements of the Industrial Safety of the Labour Act.

#### Decommissioning:

No special requirements.

### Monitoring

- Identify key performance indicators such as lost time injury, medical treatment and accidents.
- Put in place a monthly statistics recording accidents.
- Investigate the cause of any accidents that may have occurred

### Deliverables/Compliance Criteria

- Demonstrate to the OHS inspectorate that the contractor has an effective OHS management system.
- Safe working environment.

### Corrective Action

- Ensure that the accident is not repeated
- Junior staff trained to takeover safety responsibilities when responsible staff is absent from project site
- Formulate Emergency Response Plans

## Action Plan 8 - Waste Excavation Disposal

### Objectives

To manage the removal and deposition of excavated material from the construction sites for future use in order to minimise environmental impact

Handwritten signature or initials.

## Tasks

### Before Construction:

- Inspect selected waste excavation disposal areas as agreed with the Engineer. e.g. area that is clear of future works with ease of construction of toe drains around stockpile.
- Disposal site is to be located at least 30m away from the adjacent streams, on elevated ground.
- Install perimeter drains, silt traps or ponds around the site to prevent any discharge of silt-laden water into rivers or adjacent streams.

### During Construction:

- Adhere to dump site operational instructions.
- Excavated material is to be stockpiled, compacted by track rolling and shaped to blend with existing topography on area approved by the Engineer

### Decommissioning:

At the completion of use of site. Re-topsoil and re-vegetate the area with soil and vegetation close to its previous condition.

## Monitoring

Inspect the disposal site regularly to ensure waste excavation instructions are adhered to.

## Deliverables/Compliance Criteria

No adverse effects on all waterways, original site and adjacent land.

## Corrective Action

- Train staff in the daily operational procedures of the site.
- Inform the Engineer and issue stop work instructions if procedures not followed.

## Specific Monitoring Strategies

### Terrestrial and Freshwater Flora and Fauna Monitoring

Annual assessment of terrestrial and freshwater flora and fauna within the project area in respect to any impact from the project.

### Water Quality Monitoring

The primary objective of the water quality monitoring program is to:

- conform compliance with statutory regulations;
- provide data necessary for evaluating the environmental performance;
- assess the impact of the construction on water quality and the need for remedial measures;
- alert site management and appropriate authorities of potential environmental problems or other recurring pollution incident; and
- allow for a periodic review of mitigating measures and safeguards.

A  
B

The sites are to be monitored bi-annually during construction.

The following parameters will be monitored in each survey:

- parameters agreed with CEA including temperature, pH, electrical conductivity, turbidity, dissolved oxygen

Multi-element scans will be conducted.

The undertaking of this monitoring program will provide a basis from which the impact of activity of construction will be assessed. Such a program will be reviewed and may extend into the operational phase if necessary.

Where such damage is an unavoidable consequence of the construction of the Works, the Contractor shall diligently execute such measures to mitigate or repair such damage as are specified herein including but not necessarily limited to landscaping and topsoiling of spoil areas and borrow pits, arranging drainage of borrow pits and spoil areas to prevent scour and subsequent siltation or pollution of water courses with silt, topsoiling of the specified areas of the Permanent Works and the provision of replacement trees as provided for by the specification.

Waste oil shall not be discharged on to the ground or into water courses but shall be collected and disposed of in a manner approved by the Engineer.

All waste or rubbish shall be disposed of at approved locations. Trees both within and outside the Site shall be carefully protected against any damage unless the removal of such trees is necessary for the execution of the works.

If in the opinion of the Engineer the Contractor fails to comply with the provisions of this clause or any provision relating to the care of the natural environment, the Engineer may arrange for necessary measures to be implemented by others and to recover the cost from payments due to the Contractor or from retention monies or from Performance securities held by the Client.





## **106 - INVESTIGATIONS, DESIGN AND PREPARATION OF CONSTRUCTION DOCUMENTS**

### **106.1 Description**

The Contractor shall carry out and be responsible for the design of the entire works other than the parts of the works for which detailed designs are given in the contract. The contractor shall also be responsible for the design necessitated in remedying any defects in the works.

The detailed design shall be carried out in accordance with the following and all other requirements of the contract.

The Pavement Design shall be based on the following documents:

- Overseas Road Note 31 – Transport Research Laboratory, Fourth Edition, 1993
- A Guide to the Structural Design of Roads under Sri Lankan Conditions – RDA Publication

The Design of Structures shall be based on the following documents:

- Design Code BS 5400
- Bridge Design Manual – RDA Publication 1997

The Geometric Design shall be based on the following documents:

- Austroads -2009 (for Expressway)
- AASHTO-2004 (for Expressway)
- Guide to the Geometric Design of Roads – RDA Publication 1998 (for other than Expressway)

The contractor shall carry out the detailed designs based on preliminary designs / outline designs / conceptual designs carried out by the Employer and given in the contract. The outcomes of the design, including working drawings, shall have sufficient details in compliance with the contract documents to the satisfaction of the Engineer. The designs require the approval of the Engineer.

The surveys and investigations to be carried out by the Contractor in respect of the design of the entire works, as detailed in the specifications or otherwise required shall be deemed to be a part of the design.

### **106.2 Measurement and Payments**

The rate shall include for all costs associated with studies, tests, investigations and comprehensive design of the work including preparation of designs and construction documents required for construction of the Works.



## 107 PROVISION OF INSURANCE, BONDS AND SECURITIES

### 107.1 Description

The Contractor shall provide all necessary Insurances, Bounds, Guarantees and Securities as are required and detailed in the Tender Documents, Conditions of Contract or this Specification.

### 107.2 Measurement and Payment

Measurement shall be as a lump sum payment for all expenditure with regard to the provision of insurances, Bounds and Securities.

Payment shall be made on submission of the original Insurance, Bound, Guarantee or Security or proof of payment of the same provided that the original shall be made available to the Engineer within a reasonable time after proof of payment.

## 108 - TRAFFIC MANAGEMENT AND MAINTENANCE OF EXISTING ROADS

At least 14 days prior to the start of the Works, the Contractor shall submit to the Engineer a detailed Traffic Management Plan including programme and method statement. These shall be approved by the Engineer before the Contractor commences work, and shall show amongst other things the method of protection of the public, and give details of the hours of operation, location, types and numbers of traffic safety devices, barricades, warning signs, flagmen and the like.

In the preparation of his Traffic Management Plan including programme and method statement, the Contractor shall comply with the following:

- a) The Contractor shall conduct his operation in such a manner that no greater length or amount of work is undertaken than he can carry out efficiently having due regards to the rights and convenience of the public.
- b) The Contractor shall take particular care, when passing traffic through his Works, that all excavations and other hazards are properly protected with barriers and are illuminated at night.
- c) If the Contractor proposes a road closure he shall provide an alternative routine of the traffic, which must be approved by the Engineer and the landowners/authorities concerned before commencing the construction of any detour/deviation.
- d) The Contractor shall set out in detail the measures which will be adopted to ensure the safe and timely passage of all categories of traffic through the works. In the event that the plan includes the provision of diversions onto other roads, it shall be shown that this has been agreed with the appropriate local authorities, and such roads or tracks shall be fully maintained during the period of use by the contractor, so that they are capable of being used by saloon cars as well as all other traffic categories.
- e) The verges of the diversions shall be cleared and maintained clear for a width of at least 1.5m beyond the edge of the carriageway or such lesser width as the Engineer may agree. The surface of all diversions shall be maintained in a smooth and motorable condition, free from ruts, potholes and loose material, and the Contractor



shall constantly water all detours/deviations as necessary to keep down dust and to facilitate the proper blading and grading of the surface. All drainage works shall be maintained in good working order.

- f) The Contractor shall be responsible for the provision, erection, maintenance and removal of all temporary signs and barriers necessary for safety and convenience, to pass traffic not only upon the existing road to be constructed or realigned and such temporary roads or bridges as he may construct, but also on all minor and private roads off the site of the Works which are used as diversions. Particular care shall be taken to ensure that all signs, barriers, and lighting are clearly visible at night and at times of heavy rain. Temporary advance detour signs shall be erected before any road junction, and a detour sign shall be erected at both ends of any diversion and at other minor roads where there is any possibility of the diverted traffic mistaking the route of the detour. Temporary signs and barriers shall conform with the requirements of "Manual on Traffic Control Devices, Part II, July 2004" prepared by the National Road Safety Secretariat.
- g) Where in the opinion of the Engineer, it is impracticable to provide a two-lane diversion, a single lane carriageway not less than 3.0m wide with traffic control and passing places at 250m intervals shall be provided. Each passing place shall be not less than 20m long, and provide an additional width of 3.5m. The continuous length in which single lane passage is provided shall not exceed 500m at any one location without the Engineer's prior approval. The Contractor shall furnish sufficient competent flagmen, Stop-Go boards and the like to control and regulate the flow of traffic under one-way traffic operations.
- h) Any damages to existing roads or land caused by the Contractor shall be reinstated at his own expense, including the cost of repair for any damages to structures, utilities or watercourses. If required by the Engineer, such temporary routes shall be restored to the original contour and made impassable to vehicular traffic. The surfaces shall be scarified as needed to provide a condition which shall facilitate natural re-vegetation, provide for proper drainage, and prevent erosion.
- i) The traffic management programme and method statement shall conform in all respects with the requirements of the Technical Specification.

During the day, plant and equipment working in position adjacent to traffic and having a projection beyond the normal width of the unit, for example a grader blade, shall have a fluorescent red marker attached to the outer end of the projection. During poor light conditions or at night, an additional traffic controller with an illuminated red wand shall direct traffic around such plant and equipment.

At night, all plant items and similar obstructions shall be removed from the normal path of vehicles, to provide a lateral clearance of at least 6m where practicable, with a minimum clearance of 1.2m. plant and equipment within 6m of the normal path of vehicles, shall be not less than two yellow steady lamps suspended vertically from the point of the obstruction nearest to a traffic lane, and one yellow steady lamp at each end of the obstruction on the side farthest away from the traffic lane.

No revisions shall be made to the approved traffic management programme and method statement without the prior written permission of the Engineer, and the Contractor shall allow 7 days for the Engineer to review any request for a revision thereof.

The Contractor's obligations to undertake traffic management and maintenance of existing roads shall continue unless or until attendance is no longer required.



### Maintenance of the Existing Haul Road.

The Contractor shall maintain the whole of the existing road where and when required by the Engineer:

- Scarification, grading, watering and rolling of the existing road to maintain a fair running surface
- Repair of potholes and depressions
- Cutting, reshaping and deepening where necessary, side drains and ditches
- Clearing and maintaining culverts
- Clearing and maintaining existing watercourses
- Clearing and trimming of verges and intrusive bush growth

The Contractor's obligations to maintain any part or all of the existing haul road under this sub-section shall cease when any part or all of the Works has been taken over by the Employer.

### 108.1 Measurement and Payment

#### a. Measurement

Arrangement for traffic during construction shall be measured per month and the quantity of work for payment during the month shall be assessed by the Engineer on the Contractor's claim.

#### b. Payment

Payments shall be determined by the Engineer on the proportionate completed works during a month in accordance with the Clause 108.

### 109 ADMINISTRATIVE COSTS OF THE PROJECT MANAGEMENT UNIT

#### 109.1 Description

The Administrative Costs of the Project Management Unit shall be included in the Bill of Quantities of the civil works contract. This item shall cover costs in respect of rentals of buildings and vehicles, fuel, equipment purchases and installation, hiring of employees etc.

#### 109.2 Payment

The Contractor shall make payments to the relevant agencies, organizations, or individuals for services rendered in respect of rentals of buildings and vehicles, fuel, equipment purchases and installation, hiring of employees etc. on the certification of the Employer.

Payment in respect of the above expenditure shall be reimbursed to the contractor inclusive of an overhead component of 15% of the cost through the interim payment certificates upon submission of proof that such payment has been made to the relevant party through a banker's cheque acceptable to the Employer.

7  
82

**110 - PAY ITEMS AND BASIS OF PAYMENT**

The various pay items for this work section are to be as listed in Section 100 of the Bill of Quantities.

The rates for all pay items inserted in Section 100 will be considered as full and final payment for all the Contractor's obligations as per these Specifications.

A  
Bd



## APPENDIX 1

### LIST OF STANDARDS

The Contractor shall provide for the use of the Engineer technical publications, standards and codes of practice, stipulated by the Engineer. In all cases original publications of the edition currently in force are assumed. The type of publications requested may include:

- Sri Lankan Standards
- British Standards
- AASHTO publications
- ASTM publications
- FIDIC publications
- HMSO publications
- TRL publications
- Any other relevant Books or Publications

The books and publications shall become the property of the Employer upon completion of Contact

**APPENDIX - 2**

**OFFICES FOR ENGINEER AND EMPLOYER**

The Contractor shall also provide all items listed in the attached Schedules.

All offices shall be of durable standard to the satisfaction of the Engineer. Offices shall be supplied with hot and cold water air conditioned, electricity and electrical fittings to British Standards or to those of the Ceylon Electricity Board, whichever is more stringent. Offices shall be provided with adequate facilities for the disposal of waste water and sewage to the satisfaction of the Engineer. Such facilities shall be connected to individual or communal septic tanks of sufficient capacity.

Throughout the duration of the Contract, the Contractor shall ensure an uninterrupted supply of gas, water and electricity to the offices.

**The Main Type A Office requirements on this Contract are as follows**

Room No	Description	Minimum Size	No	Area m <sup>2</sup>
1	Team Leader	5m x 4m	1	20
2	Conference Room	8m x 4m	1	32
3	Senior Contract/ Claim Specialist	3m x 3m	1	9
4	02 Resident Engineers( Bridges& Highways)	3m x 4m	1	12
5	Contracts/ Claims Engineer & Assistant Contract/ Claims Engineer	5m x 3m	1	15
6	Chief QS & QS(2)	5m x 3m	1	15
7	Highway/ Bridge Engineers(2)	5m x 3m	1	15
8	Environmental Specialist & Geotechnical Engineer(2)	5m x 3m	1	15
9	Programming/ Drainage Design Engineer(2)	5m x 3m	1	15
10	Materials/Pavement Engineer(2)	5m x 3m	1	15
11	Assistant Engineers(2)	5m x 3m	1	15
13	Site Inspectors(3)	5m x 4m	1	20
14	QS CAD Operator and QS Claims/ Variations Assistants(2)	5m x 3m	1	15
15	CAD Operators(2)	5m x 4m	1	20
16	Office Manager & Admin Assistant/ Jnr. Secretary	5m x 4m	1	20
17	Secretary and Computer Operator	5m x 3m	1	15
18	Store Room	5m x 3m	1	15
19	Kitchen	6m x 2.4m	1	14
20	Dining	4m x 2.5m	1	10
19	Toilets /shower	5.1m x 4m	unit	20
20	Toilet	3m x 1m	1	3
				330

A  
OS

**OFFICES FOR THE ENGINEER – FURNITURE AND EQUIPMENT**  
**Schedule**

The new fittings required under this Contract for the site offices indicated in the schedule of offices shall be to the Engineer's approval and are as follows.

**Office Type A**

DESCRIPTION	No.
<b>A. Offices</b>	
The Main Office of gross floor area 250sq.m. in close proximity to the Contractor's Main Site Office.	1
Office rooms	7
Conference rooms	1
Bathrooms – male	2
Bathrooms – female	2
Kitchen	1
Store room	1
Lunch room	1
<b>B. Furniture</b>	
Office desks, L shape, 150x75cm with 130x45 cm computer credenza and each having at least 3 drawers, one of which is lockable.	2
Office desks, L shape, 120x70cm with 120x45 cm computer credenza and each having at least 3 drawers, one of which is lockable.	6
Office desks, 120x70cm and each having at least 3 drawers, one of which is lockable.	12
Computer desks.	12
Executive chairs with gas lift height adjustment and arm rests (High Back).	2
Executive chairs with gas lift height adjustment and arm rests( Medium Back).	6
Executive chairs with arm rests( Low Back).	12
Typist chairs with gas lift height adjustment and arm rests.	12
Visitor's chairs.	30
Steel filing cabinets with four drawers.	8
Book shelves, 1m. x 2m. with 3 shelves and lockable cupboard at base.	9
Storage cabinets 1mx2m, two door, lockable.	5
Conference table to sit 25.	1
Conference room chairs.	25
Office table with glass top	3
Bulletin board 0.9x0.6m.	5
Bulletin board 1.2x0.8m.	3
White marker board 1.2mx0.8m.	4
Office safe 0.125cu.m secured to the building.	1
Waste paper baskets	15
Coat stands	4
Plan chest – AO Type – 5 drawers.	1
Window blinds/curtains to all windows.	1 set
<b>C. Equipment</b>	
Internationally Reputed Brand Personal Computer, Inter <sup>®</sup> Core <sup>™</sup> i7 -960; 3.20 GHz Processor, 8GB upgradable up to 24GB DDR3 RAM, 500GB SATA 7200rpm Hard Drive, DVD/RW SATA, Modem, 101 Key English USB Key Board, 1 Parallel, 1 Serial, 10 USB 2.0 Ports, Mouse Port, PS/2 KeyBoard Port, External Microphone, RJ45, VGA Card, 19" TFT Flat Screen Monitor supporting 1280x1024 resolution at 75Hz, Optical Mouse with scroll wheel and mouse pad, licensed Windows 7 Professional, Kaspersky Internet Security Virus Guard; 3 Years comprehensive warranty	9
Uninterrupted Power Supply, On line Unit 1 kVA with sealed maintenance free battery and 60 minutes backup time.	9
Internationally reputed Brand Note Book PC: 3 <sup>rd</sup> Generation Intel <sup>®</sup> Core <sup>™</sup> i7 Processor, DDR3 SDRAM, 1600MHz supporting upto 16GB Memory; 500GB 7200rpm Hard Drive; 14" diagonal LED Backlit HD. Anti glare(1366x768); Intel <sup>®</sup> HD Graphics 4000; SRS PRO Audio/ Integrated Stereo Speakers; 720p HD Web cam; 4 x USB 2.0 ports; Charging Port; 1 RJ-45(Ethernet); 1 VGA; 1 Display port; Headphone/microphone combo port; DVD/RW Drive; Integrated Wireless LAN; Bluetooth; Network slot; licensed Windows 7 Professional, Kaspersky Internet Security Virus Guard; 3 Years comprehensive warranty	3

A  
B

LAN (24 hub) wiring loops for desktop computers and printers	1
Broadband wireless internet connection linked to the office LAN with capacity to provide internet services to all computers on network.	1
A3/A4 Ink jet colour printer.	2
A4 laser jet printer. (Minimum 20 pages per minute; 1200x1200dpi; 64 MB RAM; 375MHz Processor	9
Computer software, licensed copies of MS Project - latest available version.	4
Computer software, licensed copies of AUTOCAD latest available version.	2
Telephone lines at least one capable of international direct dialing.	3
12 phone exchange with handset in each office.	1
Mobile cellular phones with SIMM cards.	8
Plain paper fax machine, with multi function as printer and scanner.	2
Heavy duty photocopier with laser/digital technology, minimum 65 copies per minute, magnification of +25 to 400% in 1% steps. original print area A3 and paper size A3 to A6, resolution 600dpi minimum, continuous copying of 500 pages minimum, scan memory of 1GB minimum, System Hard Disk at least 80GB. System Processor 600MHz or more. Electronic/ Automatic copy sorting capacity of 85 sheets each set up to 20 sets. capable of network printing and supplied with stand. Auto shut off/ standby arrangement.	1
Desktop multifunctional Laser Colour Photocopier( Copier, printer, Colour scanner etc. 35 copies per minute minimum (A4 Colour/B&W); Minimum 500 pages continuous copying. Maximum original size A3; Zoom Range 25% -400% In 1% steps; System Processor 1 GHz. System Memory 2 GB; System Hard Disk 250GB Minimum; Exposure Modes Automatic & Manual 5 steps (Minimum); Electronic/ Automatically copy sorting.	1
Copier/ Digital duplicator 256 MB RAM and 40GB Hard Disk; 25 Copies per Minute minimum; Electronic Filing System; 2x 550 Sheet Cassettes & Duplex capacity.	1
Digital camera; minimum 14 MP with 5x optical zoom.	3
Multimedia Projector with remote control	1
Mechanical comb binding machine.	2
Heavy duty Stapler	1
Refrigerator (300 litre) with separate deep freezer	1
Two ring gas cooker with grill and two gas bottles	1
Other kitchen equipments including electric kettle (2 Nos), 38 place tea set, 15 place dinner set, cutlery, kitchen disposal bin, kitchen table and work surfaces, double sink unit with draining board, wall and base kitchen units.	1 set
<b>D. Safety Equipment</b>	
Safety helmets.	30
Water/ windproof jacket and over trousers.	30
Motorcycle crash helmets.	15
Fire extinguishers - one per room	10
First aid box - stocked.	2

A  
82

Office Type B		No.
DESCRIPTION		
<b>A. Offices</b>		
Office of the Employer of gross floor area 180sq.m. minimum each located close to the Contractor's Main Site Office.		1
Office rooms		4
Conference rooms		1
Bathrooms - male		2
Bathrooms - female		1
Kitchen		1
Store room		1
Lunch room		
<b>B. Furniture</b>		
Office desks, L shape, 150x75cm with 130x45 cm computer credenza and each having at least 3 drawers, one of which is lockable.		1
Office desks, L shape, 120x70cm with 120x45 cm computer credenza and each having at least 3 drawers, one of which is lockable.		1
Office desks, 120x70cm and each having at least 3 drawers, one of which is lockable.		5
Computer desks.		5
Executive chairs with gas lift height adjustment and arm rests (High Back).		2
Executive chairs with gas lift height adjustment and arm rests (Medium Back).		5
Typist chairs, gas lift height adjustment, arm rests.		5
Visitor's chairs.		15
Steel filing cabinets with four drawers.		3
Book shelves, 1bx2x with 3 shelves and lockable cupboard at base.		4
Storage cabinets 1mx2m, two door, lockable.		3
Conference table to sit 15		1
Conference room chairs.		15
Office table with glass top		1
Bulletin board 0.9x0.6m.		2
Bulletin board 1.2x0.8m.		1
White marker board 1.2mx0.8m.		2
Office safe 0.125cu.m secured to the building.		1
Waste paper baskets		5
Coat stands		1
Plan chest - AO Type - 5 drawers.		1
Window blinds/curtains to all windows.		1 set
<b>C. Equipment</b>		
Internationally reputed Brand Note Book PC: 3 <sup>rd</sup> Generation Intel® Core™ i7 Processor, DDR3 SDRAM, 1600MHz supporting upto 16GB Memory; 500GB 7200rpm Hard Drive; 14" diagonal LED Backlit HD. Anti glare(1366x768); Intel® HD Graphics 4000; SRS PRO Audio/Integrated Stereo Speakers; 720p HD Web cam; 4 x USB 2.0 ports; Charging Port; 1 RJ-45(Ethernet); 1 VGA; 1 Display port; Headphone/microphone combo port; DVD/RW Drive; Integrated Wireless LAN; Bluetooth; Network slot; licensed Windows 7 Professional, Kaspersky Internet Security Virus Guard; 3 Years comprehensive warranty		4
Internationally Reputed Brand Personal Computer, Inter® Core™ i7 -860; 3.20 GHz Processor, 8GB upgradable up to 24GB DDR3 RAM, 500GB SATA 7200rpm Hard Drive, DVD/RW SATA, Modem, 101 Key English USB Key Board, 1 Parallel, 1 Serial, 10 USB 2.0 Ports, Mouse Port, PS/2 KeyBoard Port, External Microphone, RJ45, VGA Card, 19" TFT Flat Screen Monitor supporting 1280x1024 resolution at 75Hz, Optical Mouse with scroll wheel and mouse pad, licensed Windows 7 Professional, Kaspersky Internet Security Virus Guard; 3 Years comprehensive warranty		5
Uninterrupted Power Supply. On line Unit 1 kVA with sealed maintenance free battery and 60 minutes backup time.		3
LAN (8 hub) wiring loops for desktop computers and printers		
Broadband wireless internet connection linked to the office LAN with capacity to provide internet services to all computers on network.		1
A3 / A4 laser jet printer.		2
Computer software, licensed copies of MS Project - latest available version.		2
Computer software, licensed copies of AUTOCAD latest available version.		1
Telephone lines at least one capable of international direct dialing.		2

↑  



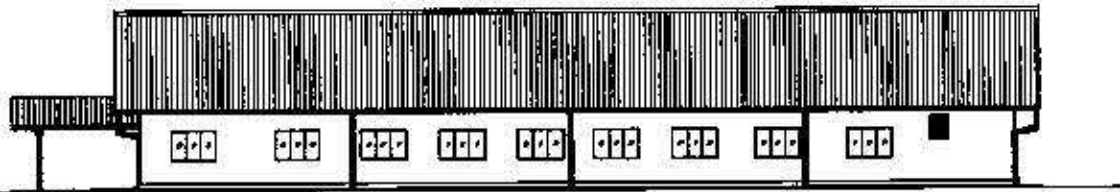

B phone exchange with handset in each office.	1
Mobile cellular phones with SIMM cards.	5
Plain paper fax machine, with multi function as printer and scanner.	1
Heavy duty photocopier with laser/digital technology, minimum 65 copies per minute, magnification of +25 to 400% in 1% steps, original print area A3 and paper size A3 to A6, resolution 600dpi minimum, continuous copying of 500 pages minimum, scan memory of 1GB minimum, System Hard Disk at least 80GB. System Processor 600MHz or more. Electronic/ Automatic copy sorting capacity of 85 sheets each set up to 20 sets, capable of network printing and supplied with stand. Auto shut off/ standby arrangement.	1
Digital camera; minimum 14 MP with 5x optical zoom.	1
Mechanical comb binding machine.	1
Heavy duty Stapler	1
Kitchen equipment including refrigerator (300 litre) with separate deepfreeze, electric kettle, 24 place tea set, 12 place dinner set, cutlery, kitchen disposal bin, kitchen table and work surfaces, double sink unit with draining board, wall and base kitchen units.	1set
<b>D. Safety Equipment</b>	6
Safety helmets.	6
Water/ windproof jacket and over trousers.	6
Fire extinguishers - at least one per room	1
First aid box - stocked.	

2  
BL

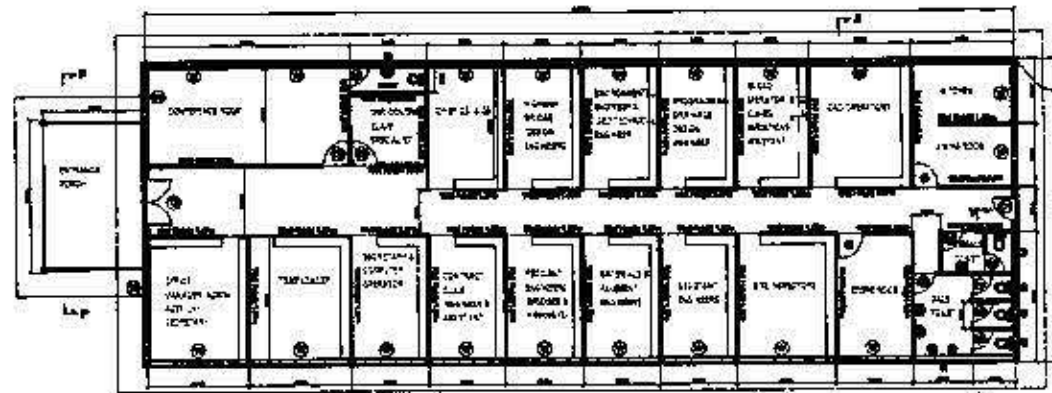

**SIDE ELEVATION**  
Scale 1:200



**PLAN**  
Scale 1:200

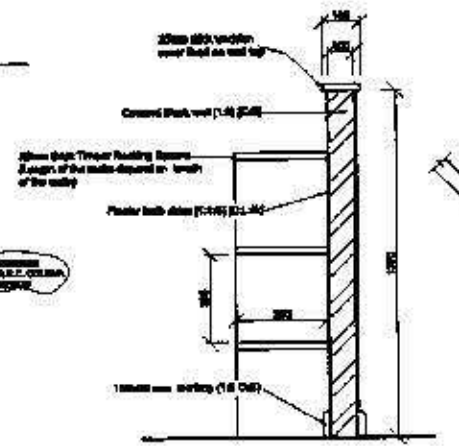

**SECTION - PARTION WALL**  
Scale 1:20

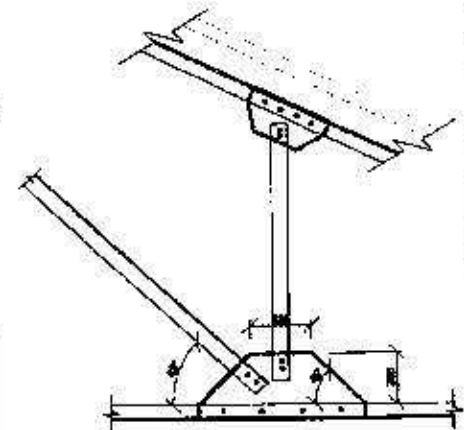

**DETAIL 'C'**  
Scale 1:20

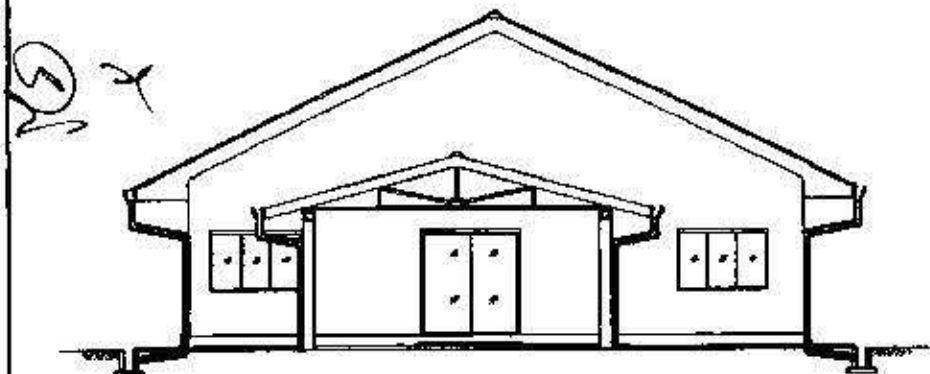

**SECTION P - P**  
Scale 1:100

SCHEDULE OF DOORS & WINDOWS			
Type	Size (mm)	Description	Qty
D	1800x2100	Striped Plywood Double Flush Glazed Door	01
D1	1800x2100	Striped Plywood Glazed Door with 1.5 gauge Aluminium Frame	01
D2	1800x2100	Plywood Door	04
D3	900x2100	PVC Door	07
W	1800x1200	Striped Plywood Glazed Window with 1.5 gauge Aluminium Frame	01
F	750x200	Striped Plywood Glazed Panel with 1.5 gauge Aluminium Frame	08

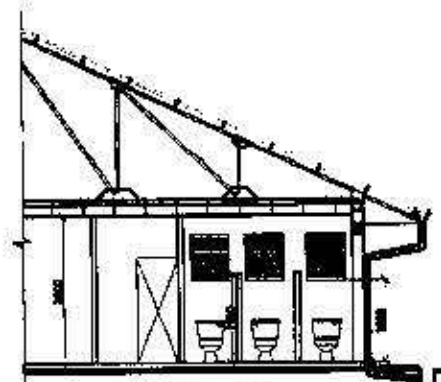

**SECTION Y - Y**  
Scale 1:100

- Notes:
1. All dimensions are in millimetres.
  2. Ceiling shall be in Central Air Conditioning system.
  3. All Outer walls to be in 225mm brick block work.
  4. All inner walls to be in 100mm brick compact block work.

DEMOCRATIC SOCIALIST REPUBLIC OF SRI LANKA  
MINISTRY OF PORTS AND HIGHWAYS  
**Road Development Authority**

SOUTHERN EXPRESSWAY EXTENSION PROJECT  
FROM MATARA TO HAMBANTOTA  
FUNDED BY EXPORT IMPORT BANK OF CHINA

BUILDING TYPE 'A'

DESIGNED BY:	
CHECKED BY:	
APPROVED BY:	
DWG. NO.	SEP/DRG/BLD TYPE 'A'
DATE	08/11/2024



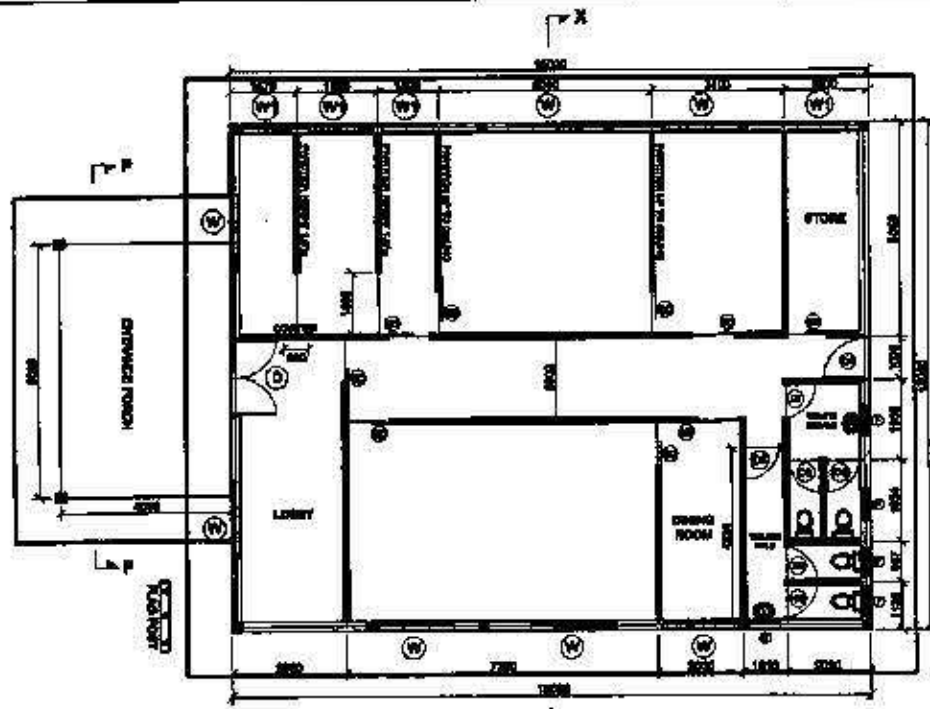

PLAN

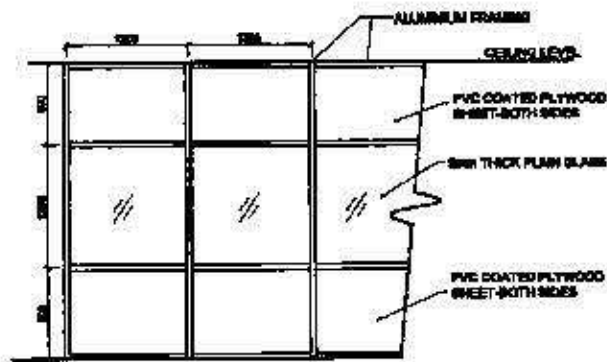

ELEVATION OF ALUMINUM FRAMED PARTITION

Scale 1:30

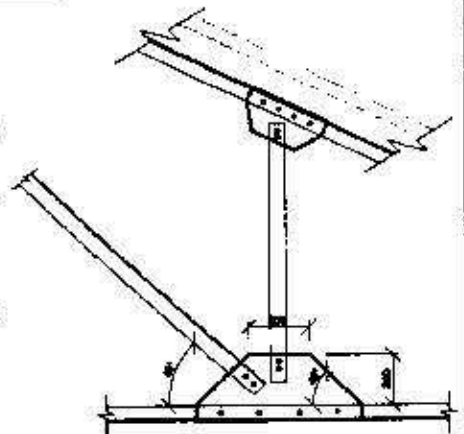

DETAIL 'C'

Scale 1:30

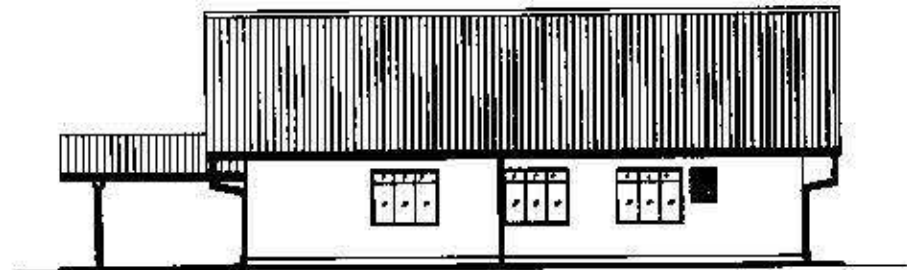

SIDE ELEVATION

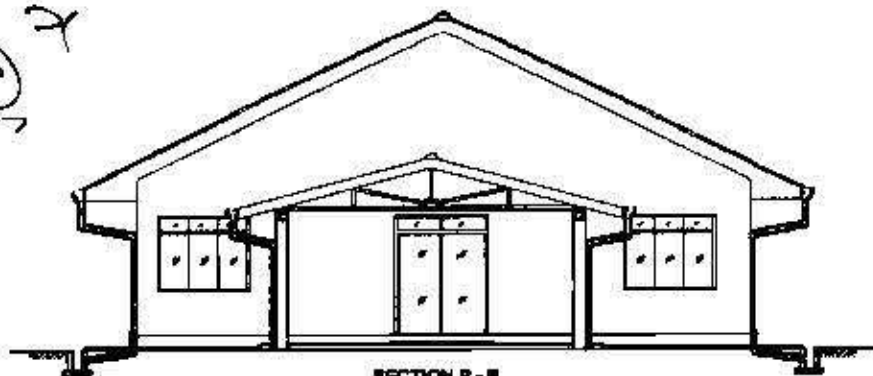

SECTION P-P  
Scale 1:100

SCHEDULE OF DOORS & WINDOWS

Type	Size (mm)	Description	Qty
D	1800x2400	5mm Plain Glass Door with 1.8 gage Aluminium Frame	01
W1	1000x2000	5mm	01
WD	1000x2100	Aluminium Sliding Door	02
D2	800x2100	PVC Door	02
W	1800x1800	5mm Plain Glass Window with 1.8 gage Aluminium Frame	02
W1	1200x1800	5mm Plain Glass Window with 1.8 gage Aluminium Frame	01
F	725x900	Do	02

Notes:

- All Dimensions are in millimeters.
- Soil Type Air Condition for the Areas of B/SFD
- Engineers
- Technical Offices / Clerk, Computer Ops. / B/SFD, E/SFD
- Contractors
- All Outer walls to be in 225mm thick brick work.
- All Inner walls to be in 100mm thick cement block work.

DEMOCRATIC SOCIALIST REPUBLIC OF SRI LANKA  
MINISTRY OF PORTS AND HIGHWAYS  
Road Development Authority

SOUTHERN EXPRESSWAY EXTENSION PROJECT  
FROM MATARA TO HAMBANTOTA  
FUNDED BY EXPORT IMPORT BANK OF CHINA

DESIGNED BY:  
CHECKED BY:  
APPROVED BY:  
DRAWING NO. SEP-ORC/2017/12  
SHEET 1 OF 2

REVISION DATE

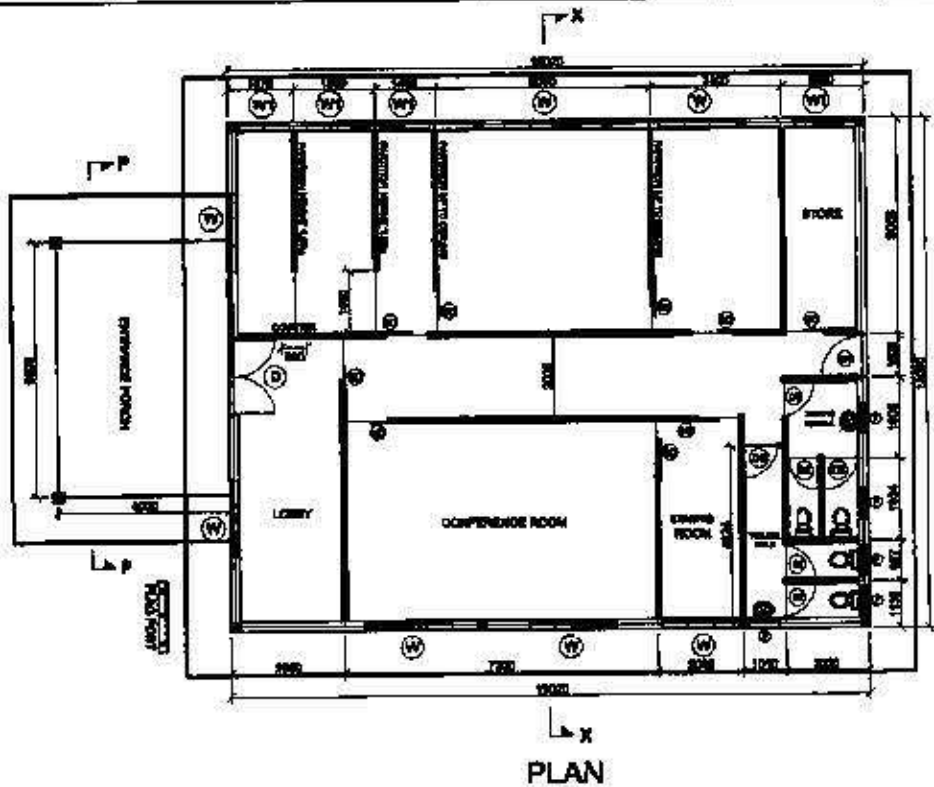

PLAN

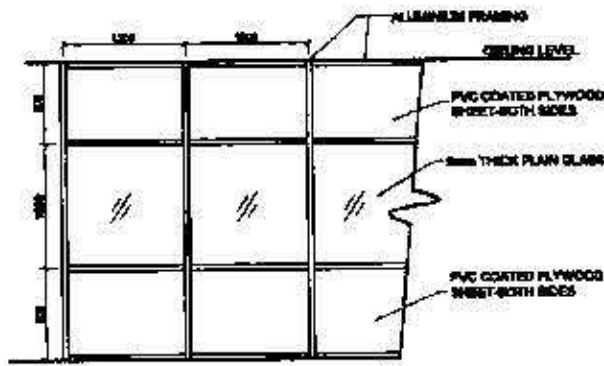

ELEVATION OF ALUMINUM FRAMED PARTITION

Scale 1:30

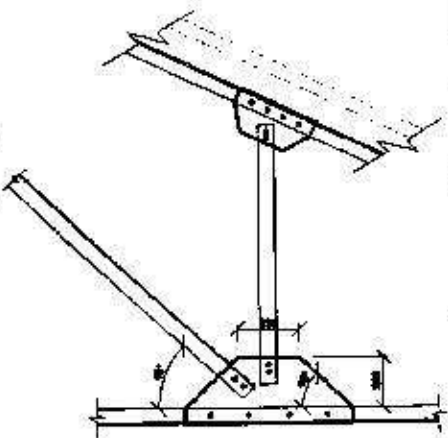

DETAIL 'C'

Scale 1:20

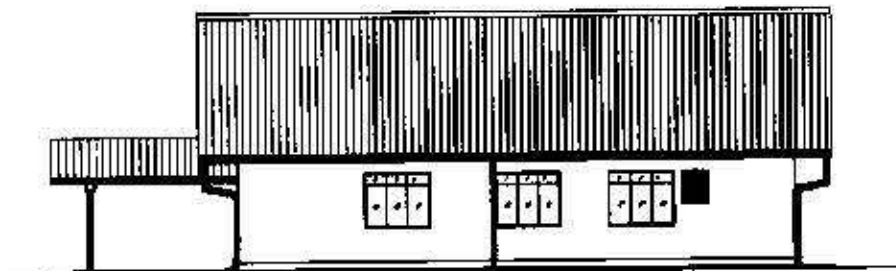

SIDE ELEVATION

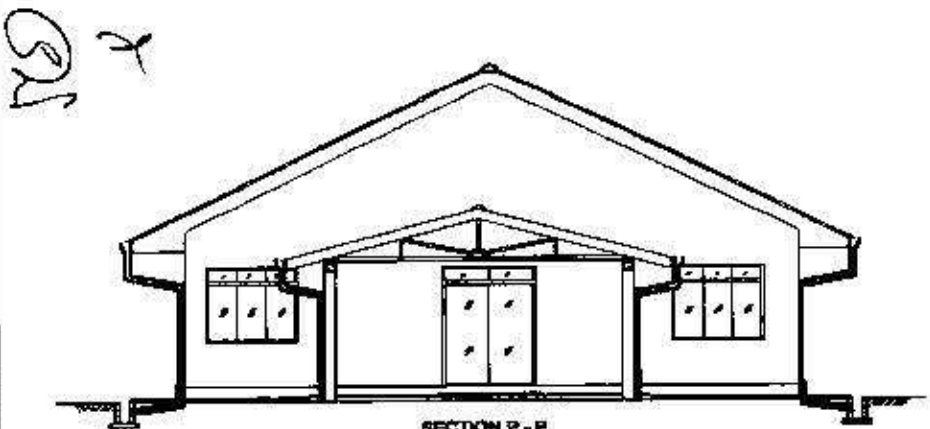

SECTION P-P

Scale 1:100

SCHEDULE OF DOORS & WINDOWS			
Type	Qty (mm)	Description	Note
D	1000x2100	8mm Plain Glass Door with 1.8 gage Aluminium Frame	01
D1	1000x2100	Do	01
CD	1000x2100	Aluminium Sliding Door	02
CD	800x2100	PVC Door	03
W	1800x1800	8mm Plain Glass Window with 1.8 gage Aluminium Frame	04
W1	1800x1800	8mm Plain Glass Window with 1.8 gage Aluminium Frame	01
F	750x200	Do	05

**Notes:**

1. All Dimensions are in Millimeters.
2. Split Type Air Condition for the Areas of  
 a) DPO  
 b) Engineers  
 c) Technical Officers / Clerk, Computer Ops. / SMO, SMO  
 d) Conference
3. All Door walls to be in 225mm thick brick work.
4. All inner walls to be in 150mm thick cement block work.

DEMOCRATIC SOCIALIST REPUBLIC OF SRI LANKA  
 MINISTRY OF PORTS AND HIGHWAYS  
 Road Development Authority

SOUTHERN EXPRESSWAY EXTENSION PROJECT  
 FROM MATARA TO HAMBANTOTA  
 FUNDED BY EXPORT IMPORT BANK OF CHINA

OFFICE TYPE 'B' (FOR EMPLOYER)

APPROVED BY:	
DESIGNED BY:	
APPROVED BY:	
DWG. NO.	MEP-005-BLD-TYPE B
DATE:	2023/07/11





**OFFICES FOR THE ENGINEER – FURNITURE AND EQUIPMENT  
SCHEDULE**

The new fittings required under this contract for the site offices indicated in the schedule of offices shall be to the Engineer's approval and are as follows.

**Office Type A**

Item	Description	Unit	Room No																			Total
			1	2	3	4	5	6	7	8	9	10	11	12	13	14	15	16	17	18	19	
1	Office Desks 'L' shape; 150cmx75cm computer credenza and each having at least 2 drawers, one of which is lockable.	Nos	1	-	1	-	-	-	-	-	-	-	-	-	-	-	-	-	-	-	2	
2	Office desks, L shape, 120x70cm with 120x45 cm computer credenza and each having at least 3 drawers, one of which is lockable.	Nos	-	-	-	2	-	-	-	-	-	-	-	-	-	-	-	-	-	-	2	
3	Office desks, 120x70cm and each having at least 3 drawers, one of which is lockable.	Nos	-	-	-	-	2	2	2	2	2	2	2	3	-	-	-	-	-	-	19	
4	Computer desks.	Nos	-	-	-	-	1	1	1	1	1	1	1	1	0	2	2	1	1	-	14	
5	Executive chairs with gas lift height adjustment and arm rests (High Back).	Nos	1	-	1	-	-	-	-	-	-	-	-	-	-	-	-	-	-	-	2	
6	Executive chairs with gas lift height adjustment and arm rests( Medium Back).	Nos	-	-	-	-	2	2	2	2	2	2	2	-	-	-	-	-	-	-	14	
7	Executive chairs with arm rests( Low Back).	Nos	-	-	-	-	-	-	-	-	-	-	2	3	2	-	-	-	-	-	7	
8	Typist chairs with gas lift height adjustment and arm rests.	Nos	-	-	-	-	1	1	1	1	1	1	1	1	2	2	1	1	-	-	14	
9	Visitor's chairs.	Nos	2	-	2	2	2	2	2	2	2	2	2	3	-	-	5	-	-	-	30	
10	Steel filing cabinets with four drawers.	Nos	-	-	-	-	1	1	1	1	1	1	-	-	1	-	-	3	-	-	10	
11	Book shelves, 1m. x 2m. with 3 shelves and lockable cupboard at base.	Nos	1	-	1	1	1	1	1	1	1	1	1	-	-	-	-	2	1	-	12	
12	Storage cabinets 1mx2m, two door, lockable.	Nos	1	-	1	1	1	1	1	1	1	1	-	-	-	-	-	2	1	-	11	
13	Conference table to sit 25.	Nos	-	1	-	-	-	-	-	-	-	-	-	-	-	-	-	-	-	-	1	
14	Conference room chairs.	Nos	-	25	-	-	-	-	-	-	-	-	-	-	-	-	-	-	-	-	25	
15	Office table with glass top	Nos	-	-	-	-	-	-	-	-	-	-	-	-	-	-	2	-	-	-	2	
16	In / Out trays	Nos	2	-	2	4	4	4	4	4	4	4	4	4	-	-	-	2	-	-	42	
17	Bulletin board 1.2x0.8m.	Nos	1	-	-	-	-	-	-	-	-	-	-	-	-	-	1	-	-	-	2	
18	White marker board 1.2mx0.8m.	Nos	1	-	1	1	1	1	1	1	1	-	-	-	-	-	1	-	-	-	8	
19	Office safe 0.125cu.m secured to the building.	Nos	-	-	-	-	-	-	-	-	-	-	-	-	-	-	1	-	-	-	1	
20	Waste paper baskets	Nos	1	2	1	2	2	2	2	2	2	2	2	2	2	1	1	1	1	-	28	
21	Coat stands	Nos	1	1	1	1	-	-	-	-	-	-	-	-	-	-	-	-	-	-	4	
22	Plan chest – A0 Type – 5 drawers.	Nos	-	-	-	-	-	-	-	-	-	-	-	-	-	-	1	-	-	-	1	
	Window blinds/curtains to all windows.	Nos																				Set

24	Internationally Reputed Brand Personal Computer, Inter® Core™ i7 -960; 3.20 GHz Processor, 8GB upgradable up to 24GB DDR3 RAM, 500GB SATA 7200rpm Hard Drive, DVD/RW SATA, Modem, 101 Key English USB Key Board, 1 Parallel, 1 Serial, 10 USB 2.0 Ports, Mouse Port, PS/2 KeyBoard Port, External Microphone, RJ45, VGA Card, 19" TFT Flat Screen Monitor supporting 1280x1024 resolution at 75Hz, Optical Mouse with scroll wheel and mouse pad, licensed Windows 7 Professional, Kaspersky Internet Security Virus Guard; 3 Years comprehensive warranty	Nos	-	-	-	-	2	2	2	2	2	2	2	4	-	2	2	1	1	-	-	24
25	Uninterrupted Power Supply, On line Unit 1 kVA with sealed maintenance free battery and 60 minutes backup time.	Nos	-	-	-	-	2	2	2	2	2	2	2	4	-	2	2	1	1	-	-	24
26	Internationally reputed Brand Note Book PC: 3 <sup>rd</sup> Generation Intel® Core™ i7 Processor; DDR3 SDRAM, 1600MHz supporting upto 16GB Memory; 500GB 7200rpm Hard Drive; 14" diagonal LED Backlit HD. Anti glare(1366x768); Intel® HD Graphics 4000; SRS PRO Audio/ Integrated Stereo Speakers; 720p HD Web cam; 4 x USB 2.0 ports; Charging Port; 1 RJ-45(Ethernet); 1 VGA; 1 Display port; Headphone/microphone combo port; DVD/RW Drive; Integrated Wireless LAN; Bluetooth; Network slot; licensed Windows 7 Professional, Kaspersky Internet Security Virus Guard; 3 Years comprehensive warranty	Nos	1	-	1	2	-	-	-	-	-	-	-	-	-	-	-	-	-	-	-	4
27	LAN (36 hub) wiring loops for desktop computers and printers	Nos	-	-	-	-	-	-	-	-	-	-	-	-	-	-	-	1	-	-	-	1
28	Broadband wireless internet connection linked to the office LAN with capacity to provide internet services to all computers on network.	Nos	-	-	-	-	-	-	-	-	-	-	-	-	-	-	-	1	-	-	-	1
29	A3/A4 Ink jet colour printer.	Nos	1	-	-	2	-	1	1	-	-	-	-	-	-	-	-	-	1	-	-	6
30	A4 laser jet printer. (Minimum 20 pages per minute; 1200x1200dpi; 64 MB RAM; 375MHz Processor)	Nos	1	-	1	1	2	1	1	2	2	2	2	2	-	-	-	1	1	-	-	19
31	Computer software, licensed copies of MS Project – latest available version.	Nos	1	-	1	2	1	1	-	-	1	-	-	-	-	-	-	-	-	-	-	7
32	Computer software, licensed copies of AUTOCAD latest available version.	Nos	1	-	-	2	-	-	2	-	-	-	-	-	-	-	-	-	-	-	-	5
33	Telephone lines at least one capable of international direct dialing.	Nos	1	-	1	1	1	-	-	-	-	-	-	-	-	-	-	1	-	-	-	5
34	12 phone exchange with handset in each office.	Nos	-	-	-	-	-	-	-	-	-	-	-	-	-	-	-	-	-	-	-	0
35	Mobile cellular phones with SIMM cards.	Nos	1	-	1	2	2	2	2	2	2	2	2	2	3	2	2	1	-	-	-	28
36	Plain paper fax machine, with multi function as printer and scanner.	Nos	1	-	-	1	-	-	-	-	-	-	-	-	-	-	-	1	-	-	-	3
37	Heavy duty photocopier with laser/digital technology, minimum 65 copies per minute, magnification of +25 to 400% in 1% steps. original print area A3 and paper size A3 to A6, resolution 600dpi minimum, continuous copying of 500 pages minimum, scan memory of 1GB minimum, System Hard Disk at least 80GB. System Processor 600MHz or more. Electronic/ Automatic copy sorting capacity of 85 sheets each set up to 20 sets. capable of network printing and supplied with stand. Auto shut off/ standby arrangement.	Nos	-	-	-	-	-	-	-	-	-	-	-	-	-	-	-	1	-	-	-	1

38	Desktop multifunctional Laser Colour Photocopier( Copier, printer, Colour scanner etc. 35 copies per minute minimum (A4 Colour/B&W); Minimum 500 pages continuous copying; Maximum original size A3; Zoom Range 25% - 400% in 1% steps; System Processor 1 GHz. System Memory 2 GB; System Hard Disk 250GB Minimum, Exposure Modes Automatic & Manual 5 steps (Minimum); Electronic/ Automatically copy sorting.	Nos	1	-	-	-	-	-	-	-	-	-	-	-	-	-	-	-	-	-	1
39	Copier/ Digital duplicator 256 MB RAM and 40GB Hard Disk, 25 Copies per Minute minimum; Electronic Filing System; 2x 550 Sheet Cassettes & Duplex capacity.	Nos	-	-	-	-	-	-	-	-	-	-	-	-	-	1	-	-	-	-	1
40	Digital camera; minimum 14 MP with 5x optical zoom	Nos	1	-	1	2	-	-	1	1	-	-	-	-	-	-	-	-	-	-	6
41	Multimedia Projector with remote control	Nos	-	1	-	-	-	-	-	-	-	-	-	-	-	-	-	-	-	-	1
42	Mechanical comb binding machine.	Nos	-	-	-	-	-	-	-	-	-	-	-	-	-	1	-	-	-	-	1
43	Heavy duty Stapler	Nos	-	-	-	-	-	-	-	-	-	-	-	-	-	1	-	-	-	-	1
44	Refrigerator (300 litre) with separate deep freezer	Nos	-	-	-	-	-	-	-	-	-	-	-	-	-	-	-	-	-	1	1
45	Two ring gas cooker with grill and two gas bottles	Nos	-	-	-	-	-	-	-	-	-	-	-	-	-	-	-	-	-	1	1
46	Other kitchen equipments including electric kettle (2 Nos), 36 place tea set, 15 place dinner set, cutlery, kitchen disposal bin, kitchen table and work surfaces, double sink unit with draining board, wall and base kitchen units.	Nos	-	-	-	-	-	-	-	-	-	-	-	-	-	-	-	-	-	set	0
47	Safety helmets.	Nos	-	-	-	-	-	-	-	-	-	-	-	-	-	30	-	-	-	-	30
48	Water/ windproof jacket and over trousers.	Nos	-	-	-	-	-	-	-	-	-	-	-	-	-	25	-	-	-	-	25
49	Motorcycle crash helmets.	Nos	-	-	-	-	-	-	-	-	-	-	-	-	-	15	-	-	-	-	15
50	Fire extinguishers - one per room	Nos	1	1	1	1	1	1	1	1	1	1	1	1	1	1	1	1	1	1	19
51	First aid box – stocked.	Nos	-	-	-	-	-	-	-	-	-	-	-	-	-	2	-	-	-	-	2

GA

**OFFICES FOR THE EMPLOYER – FURNITURE AND EQUIPMENT  
SCHEDULE**

The new fittings required under this contract for the site offices indicated in the schedule of offices shall be to the Engineer's approval and are as follows:  
**Office Type B**

Item	Description	Unit	Room No									Total	
			1	2	3	4	5	6	7	8	9		
1	Office desks, L shape, 150x75cm with 130x45 cm computer credenza and each having at least 3 drawers, one of which is lockable.	Nos	1	-	-	-	-	-	-	-	-	-	1
2	Office desks, L shape, 120x70cm with 120x45 cm computer credenza and each having at least 3 drawers, one of which is lockable.	Nos	-	-	1	-	-	-	-	-	-	-	1
3	Office desks, 120x70cm and each having at least 3 drawers, one of which is lockable.	Nos	-	-	1	4	-	-	-	-	-	-	5
4	Computer desks.	Nos	-	-	1	4	-	-	-	-	-	-	5
5	Executive chairs with gas lift height adjustment and arm rests (High Back).	Nos	1	-	1	-	-	-	-	-	-	-	2
6	Executive chairs with gas lift height adjustment and arm rests( Medium Back).	Nos	-	-	1	4	-	-	-	-	-	-	5
7	Typist chairs, gas lift height adjustment, arm rests.	Nos	-	-	1	4	-	-	-	-	-	-	5
8	Visitor's chairs.	Nos	2	-	2	11	-	-	-	-	-	-	15
9	Steel filing cabinets with four drawers.	Nos	1	-	1	1	-	-	-	-	-	-	3
10	Book shelves, 1bx2x with 3 shelves and lockable cupboard at base.	Nos	1	-	1	2	-	-	-	-	-	-	4
11	Storage cabinets 1mx2m, two door, lockable.	Nos	1	-	1	1	-	-	-	-	-	-	3
12	Conference table to sit 15	Nos	-	1	-	-	-	-	-	-	-	-	1
13	Conference room chairs.	Nos	-	15	-	-	-	-	-	-	-	-	15
14	Office table with glass top	Nos	-	-	-	1	-	-	-	-	-	-	1
15	In/ Out Trays	Nos	2	-	4	8	-	-	-	-	-	-	14
16	Bulletin board 1.2x0.8m.	Nos	1	-	1	2	-	-	-	-	-	-	4
17	White marker board 1.2mx0.8m.	Nos	1	-	1	1	-	-	-	-	-	-	3
18	Office safe 0.125cu.m secured to the building	Nos	1	-	-	-	-	-	-	-	-	-	1
19	Waste paper baskets	Nos	1	2	2	5	-	-	-	-	-	-	10
21	Plan chest – AO Type – 5 drawers.	Nos	-	-	-	1	-	-	-	-	-	-	1
22	Window blinds/curtains to all windows.	Nos	-	-	-	-	-	-	-	-	-	-	Set

A  
GT



23	Internationally reputed Brand Note Book PC: 3 <sup>rd</sup> Generation Intel® Core™ i7 Processor, DDR3 SDRAM,1600MHz supporting upto 16GB Memory; 500GB 7200rpm Hard Drive; 14" diagonal LED Backlit HD. Anti glare(1366x768); Intel® HD Graphics 4000; SRS PRO Audio/ Integrated Stereo Speakers; 720p HD Web cam; 4 x USB 2.0 ports; Charging Port; 1 RJ-45(Ethernet); 1 VGA; 1 Display port; Headphone/microphone combo port; DVD/RW Drive; Integrated Wireless LAN; Bluetooth; Network slot; licensed Windows 7 Professional, Kaspersky Internet Security Virus Guard; 3 Years comprehensive warranty		1		2	1														
24	Internationally Reputed Brand Personal Computer, Inter® Core™ i7 -960; 3.20 GHz Processor, 8GB upgradable up to 24GB DDR3 RAM, 500GB SATA, 7200rpm Hard Drive, DVD/RW SATA, Modem, 101 Key English USB Key Board, 1 Parallel, 1 Serial, 10 USB 2.0 Ports, Mouse Port, PS/2 KeyBoard Port, External Microphone, RJ45, VGA Card, 19" TFT Flat Screen Monitor supporting 1280x1024 resolution at 75Hz, Optical Mouse with scroll wheel and mouse pad, licensed Windows 7 Professional, Kaspersky Internet Security Virus Guard; 3 Years comprehensive warranty		1		2	2														
25	Uninterrupted Power Supply, On line Unit 1 kVA with sealed maintenance free battery and 60 minutes backup time.		1		2	2														
26	LAN (8 hub) wiring loops for desktop computers and printers	Nos	-	-	-	1	-	-	-	-	-	-	-	-	-	-	-	-	-	1
27	Broadband wireless internet connection linked to the office LAN with capacity to provide internet services to all computers on network.	Nos	1	-	1	2	-	-	-	-	-	-	-	-	-	-	-	-	-	4
28	A3 / A4 laser jet printer.	Nos	1	-	1	2	-	-	-	-	-	-	-	-	-	-	-	-	-	4
29	Computer software, licensed copies of MS Project – latest available version.	Nos	1	-	1	-	-	-	-	-	-	-	-	-	-	-	-	-	-	2
30	Computer software, licensed copies of AUTOCAD latest available version.	Nos	1	-	1	-	-	-	-	-	-	-	-	-	-	-	-	-	-	2
31	Telephone lines at least one capable of international direct dialing.	Nos	1	-	1	-	-	-	-	-	-	-	-	-	-	-	-	-	-	2
32	8 phone exchange with handset in each office	Nos	1	-	1	1	-	1	1	-	-	-	-	-	-	-	-	-	-	5
33	Mobile cellular phones with SIMM cards.	Nos	1	-	1	2	-	-	-	-	-	-	-	-	-	-	-	-	-	4
34	Plain paper fax machine, with multi function as printer and scanner.	Nos	1	-	-	1	-	-	-	-	-	-	-	-	-	-	-	-	-	2
35	Heavy duty photocopier with laser/digital technology, minimum 65 copies per minute, magnification of +25 to 400% in 1% steps, original print area A3 and	Nos	1	-	-	-	-	-	-	-	-	-	-	-	-	-	-	-	-	1
36	Digital camera; minimum 14 MP with 5x optical zoom.	Nos	1	-	1	1	-	-	-	-	-	-	-	-	-	-	-	-	-	3
37	Mechanical comb binding machine.	Nos	-	-	-	1	-	-	-	-	-	-	-	-	-	-	-	-	-	1
38	Heavy duty Stapler	Nos	-	-	-	1	-	-	-	-	-	-	-	-	-	-	-	-	-	1

GA  
K

39	Kitchen equipment including refrigerator (300 litre) with separate deepfreeze, electric kettle, 24 place tea set, 12 place dinner set, cutlery, kitchen disposal bin, kitchen table and work surfaces, double sink unit with draining board, wall and base kitchen units.	Nos	-	-	-	-	-	1	-	-	-	1
40	Desktop multifunctional Laser Colour Photocopier (Copier, printer, Colour scanner etc. 35 copies per minute minimum (A4 Colour/B&W); Minimum 500 pages continuous copying; Maximum original size A3; Zoom Range 25% - 400% in 1% steps; System Processor 1 GHz. System Memory 2 GB; System Hard Disk 250GB Minimum; Exposure Modes Automatic & Manual 5 steps (Minimum); Electronic/ Automatically copy sorting.	Nos	1	-	-	-	-	-	-	-	-	1
41	Copier/ Digital duplicator 256 MB RAM and 40GB Hard Disk; 25 Copies per Minute minimum; Electronic Filing System; 2x550 Sheet Cassettes & Duplex capacity.	Nos	-	-	-	-	1	-	-	-	-	1
42	Digital camera; minimum 14 MP with 5x optical zoom.	Nos	1	-	1	2	-	-	-	-	-	4
43	Multimedia Projector with remote control	Nos	-	1	-	-	-	-	-	-	-	1
44	Mechanical comb binding machine.	Nos	-	-	-	-	-	1	-	-	-	1
45	Heavy duty Stapler	Nos	-	-	-	-	-	1	-	-	-	1
46	Refrigerator (300 litre) with separate deep freezer	Nos	-	-	-	-	-	-	-	-	1	1
47	Two ring gas cooker with grill and two gas bottles	Nos	-	-	-	-	-	-	-	-	1	1
48	Other kitchen equipments including electric kettle (2 Nos), 36 place tea set, 15 place dinner set, cutlery, kitchen disposal bin, kitchen table and work surfaces, double sink unit with draining board, wall and base kitchen units.	Nos	-	-	-	-	-	-	-	-	1	Set
49	Safety helmets.	Nos	-	-	-	-	-	30	-	-	-	30
50	Water/ windproof jacket and over trousers.	Nos	-	-	-	-	-	25	-	-	-	25
51	Motorcycle crash helmets.	Nos	-	-	-	-	-	15	-	-	-	15
52	Fire extinguishers - one per room	Nos	1	1	1	1	1	1	1	-	-	7
53	First aid box - stocked.	Nos	-	-	-	-	-	2	-	-	-	2

BT  
f

## APPENDIX - 3

### HOUSING AND FURNITURE FOR ENGINEER & EMPLOYER

The Contractor shall provide and maintain accommodation for Engineer's Staff and for the Employer including the provision of watchmen for security purposes until the Contract Completion to the satisfaction of the Engineer. The contractor shall maintain all furniture, fittings and equipment in good repair and pay for all water, sanitary arrangements gas, kerosene and telephone and electricity services all to the approval of the Engineer.

Accommodation shall be equipped with security grills, and furniture, air-conditioning, equipment and fittings, with all windows shall be glazed and provided with blinds, security netting and insect screens. The following table 2.1 indicates the minimum ground floor requirements of the accommodation.

**Table 2.1**

Description	Number of Rooms Required		Area of each (sq.m)
	Type 'A' & 'A1'	Type 'B'	
Living/ Dining Room	1	1	40
Veranda	1	1	18
Office Room/ Study Room	1	1	12
Bed room	2	3	16
Attached Toilets/ Bathrooms	2	3	5
Kitchen	1	1	12
Pantry	1	1	12
Servants Accommodation	1	1	12
Servants Toilet	1	1	4.5
<b>Total</b>	<b>136.5</b>	<b>157.5</b>	

### 3. Furniture, Equipment and Fittings for the Accommodation of the Engineer's Site Staff

The Contractor shall provide, install and maintain and provide consumables to maintain the furniture, equipment and fittings as shown in Table 3.1, until Contract Completion and to the satisfaction of the Engineer. All of the items shall be new and subject to the approval of the Engineer.

At Contract completion, the furniture, equipment and fittings shall be handed over to the Employer.

**Table 3.1**

ITEM	DESCRIPTION	Number Required		
		TYPE 'A'	TYPE 'A1'	TYPE 'B'
Telephone Connection Independent line		1	1	1
<b>Veranda</b>				
Veranda Table	Wooden 20.mx1.0m	1	1	1

Veranda Chair		4	4	6
ITEM	DESCRIPTION	Number Required		
		TYPE 'A'	TYPE 'A1'	TYPE 'B'
<b>Living/Dining Room</b>				
Lounge Suite	1 No 3seater, 3 No. 1 seater, 1 No coffee table and 2 Nos of side tables	1	1	1
Dining Table	Wooden 2.0m x1.2m	1	1	1
Dining Room Chairs	Cushioned	4	4	4
Book case	1.0m x 0.35m x 3 shelves	1	1	1
Occasional table		1	1	1
Air Conditioner	24,000 BTU/ hour split type	1	-	-
TV set	TV set including antenna & booster)	1	1	1
<b>Office Room</b>				
Writing Desk	1.5m x 0.75m	1	1	3
Chairs		2	2	3
Book case	1.0 x 2.0 x0.35 m x 3 shelves	1	1	1
Air Conditioner	10,000BTU/hr split type	1	-	-
<b>Bed Rooms</b>				
Beds	Single with mattress and two pillows	4	4	4
	Queen size with mattress	4	4	-
Bedside cabinet		2	2	3
Dressing Table with mirror and stool		1	1	1
Chest of Drawers	1.0m high with 6 drawers	2	2	3
Wardrobe with fittings	2m high, 1.0m wide, 0.35 m deep with shelves and two doors	2	2	3
Bedside Lamp		2	2	3
Mattress covers		4	4	5
Mosquito nets	Single	4	4	4
Waste paper basket		2	2	3
Air conditioner	12,000BTU/hr split type	2	-	-
<b>Pantry</b>				
Store shelves		set	set	set
Electrical iron and ironing board		set	set	set
Pantry cupboards		set	set	set
Glass cabinet		1	1	1
Refrigerator	12 cu.ft capacity	1	1	1

BA &

ITEM	DESCRIPTION	Number Required		
		TYPE 'A'	TYPE 'A1'	TYPE 'B'
Cold water dispenser (Electric)	20 liter capacity including spring water	1	1	1
Sink unit with draining board	With hot and cold water taps and waste water outlet	1	1	1
<b>Kitchen</b>				
Kitchen cup boards		set	set	set
Kitchen Table		1	1	1
Chairs		2	2	2
Sink unit with draining board	with cold water taps and waste water outlet	1	1	1
Electrical or gas cooker	With 4- heater rings, grill	1	1	1
Electric kettle	2 liter capacity	1	1	1
Cooking Utensils/ equipment	Complete set for 6 persons	set	set	set
Crockery	Complete set for 6 persons	set	set	set
Cutlery	Complete set for 6 persons	set	set	set
Tea Service	Complete set for 6 persons	set	set	set
Plate Rack		1	1	1
<b>Servant Accommodation</b>				
Beds	Single with mattress and pillows	1	1	1
Wardrobe with fittings	2m high, 1.0m wide, 0.35 m deep with shelves and two doors	1	1	1
Armless Chairs		1	1	1
Occasional Table		1	1	1
Bedside Lamp		1	1	1
Mattress covers		2	2	2
Pillow covers		4	4	4
Mosquito Nets	Single	1	1	1
<b>General</b>				
Rugs	Complete set	1	1	1
Doormats	Complete set	1	1	1
Curtains	Complete set	1	1	1
Cleaning equipment	Complete set	1	1	1
<b>Toilet</b>		1	1	1
Cleaning equipment	Complete set	1	1	1



ITEM	DESCRIPTION	Number Required		
		TYPE 'A'	TYPE 'A1'	TYPE 'B'
Kitchen		1	1	1
Cleaning equipment General	Complete set	1	1	1

Q1 A

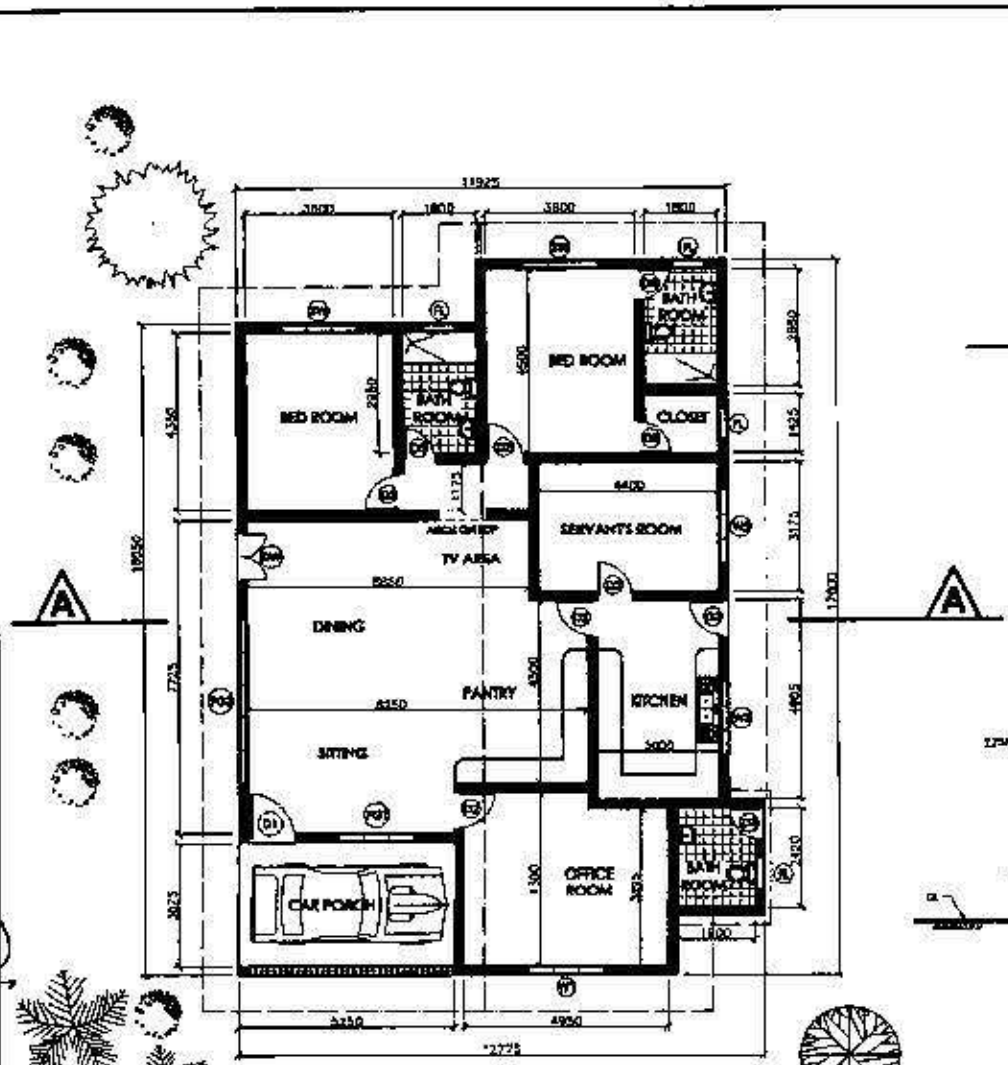

**FLOOR PLAN**  
NOT TO SCALE

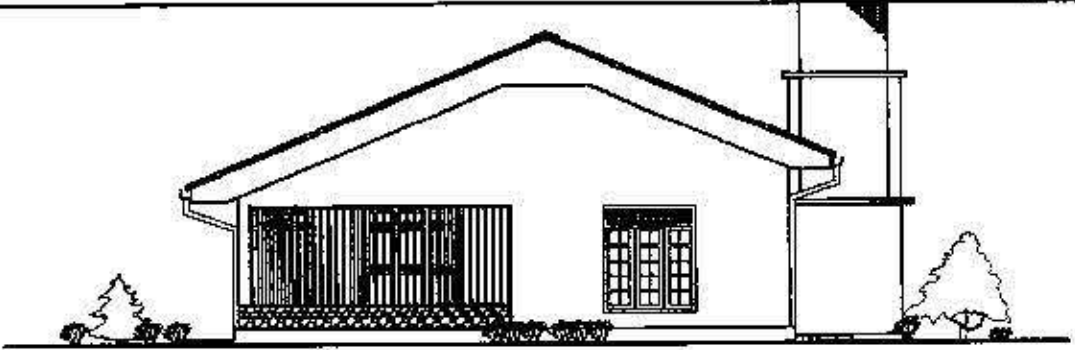

**FRONT VIEW**  
SCALE 1:100

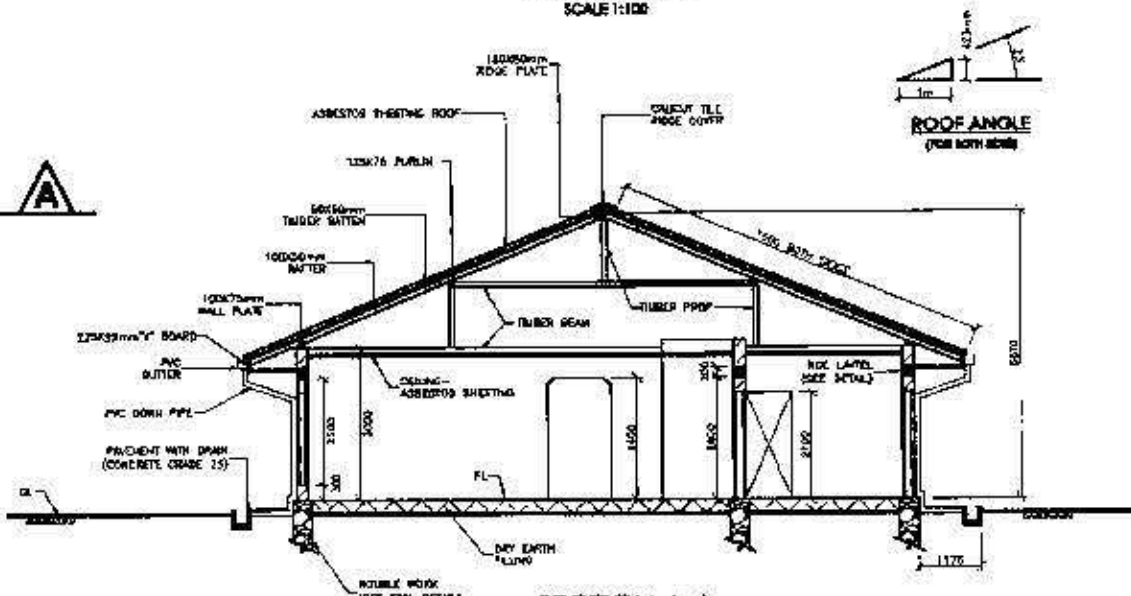

**SECTION A-A**  
SCALE 1:100

- Notes:**
1. ALL DIMENSIONS ARE IN MILLIMETERS.
  2. SCALE AS MENTIONED.
  3. ALL WALLS TO BE BUILT IN 225mm THICK BRICK.
  4. PLEASE NOTE THAT THE PREVAILING SOIL CONDITIONS AT SITE ARE NOT CONSIDERED. PRIOR TO CONSTRUCTION, ENSURE ITS SUITABILITY FOR THE FOUNDATION DESIGN.
  5. ALL BATH ROOM WALLS LINING UP TO 1500mm WITH 300x200mm GLAZED CERAMIC WALL TILES. BATH ROOM FLOORS LINING WITH 300x200mm NON-SLIP GLAZED CERAMIC FLOOR TILES.
  6. ALL FLOOR AREA EXCEPT VERANDAH & GARAGE LINING WITH NON-SLIP GLAZED CERAMIC FLOOR TILES.
  7. SIZES OF TIMBER BEAMS & PROPS FOR THE ROOF AS PER THE RECOMMENDATION OF THE ENGINEER.
  8. CAPACITY OF 2000 LITRES WATER TANK (PLASTERED) TO BE INSTALLED ON THE BATH ROOM TOP SLAB AS SHOWN IN THE FRONT VIEW.
  9. DELIVERY LINE SHOULD BE CONNECTED THROUGH A BOOSTER PUMP.

DEMOCRATIC SOCIALIST REPUBLIC OF SRI LANKA  
MINISTRY OF PORTS AND HIGHWAYS  
**Road Development Authority**

No	REVISION	DATE

SOUTHERN EXPRESSWAY EXTENSION PROJECT  
FROM MATARA TO HAMBANTOTA  
FUNDED BY EXPORT IMPORT BANK OF CHINA

ACCOMMODATION - TYPE A

DESIGNED BY:	
DRAWN BY:	
APPROVED BY:	
ENGL. NO.	
KEEPING COPY AT:	
SHEET 1 OF 2	

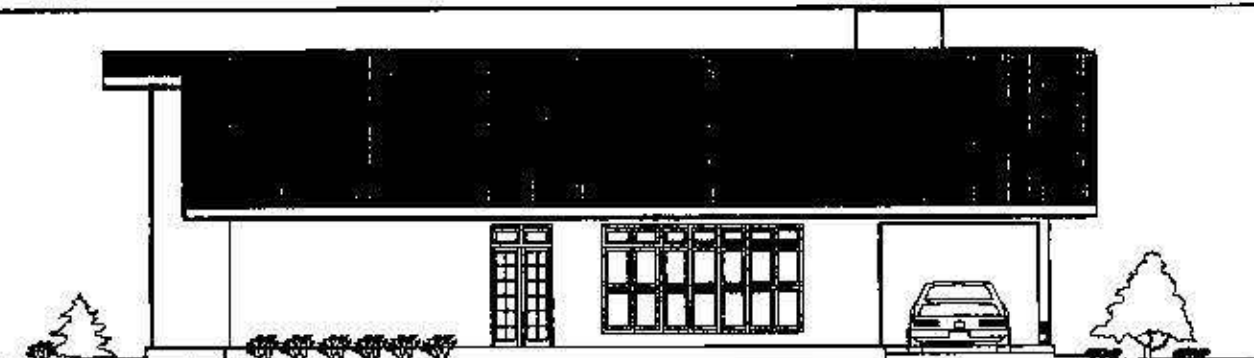

**SIDE VIEW**

SCALE 1:100

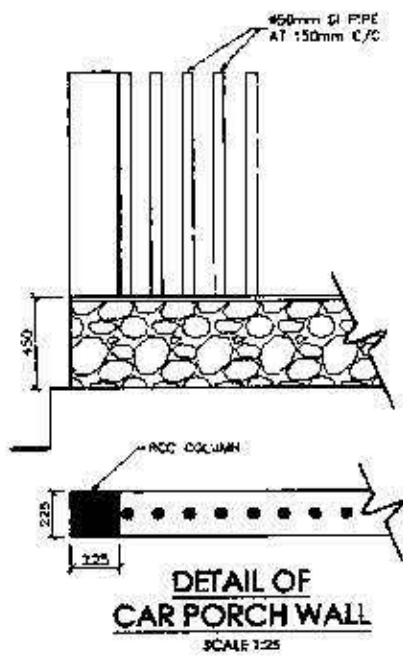
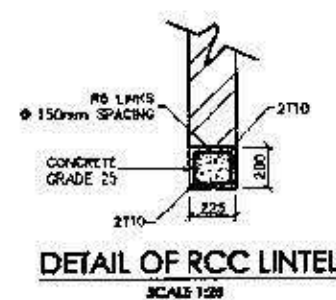

SCHEDULE OF DOORS & WINDOWS			
TYPE	SIZE	DESCRIPTION	NOS.
D1	1200x2400	FLUSH PANNELED DOOR WITH FIXED GLASS ON TOP	01
D2	900x2100	PLYWOOD DOOR	04
D3	800x1300	DOOR	04
DW	1300x2400	SCOTCH TYPE DOOR WINDOW WITH FIXED GLASS ON TOP	01
W1	1800x2100	SCOTCH TYPE WINDOW WITH GLASS ON TOP	01
W2	1800x1800	DOOR	02
SW	1800x1800	ALUMINIUM FRAMED GLAZED SLIDING WINDOW	02
WC1	1800x2100	EMBER FRAMED TOP SASH OPERABLE WINDOW	01
WC2	4000x2100	DOOR	01
FL	7200x900	GLAZED FANLIGHT WITH SLATS ON TOP	04

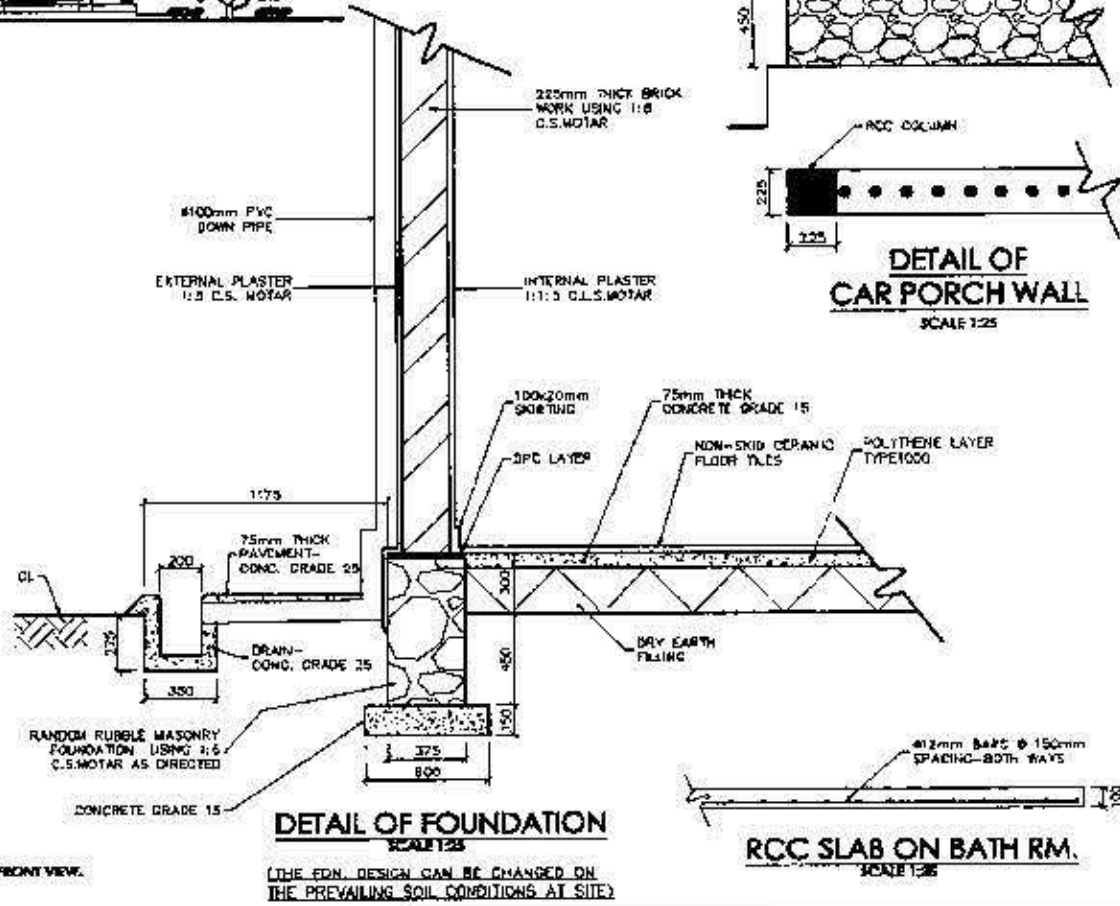

- Notes:**
- ALL DIMENSIONS ARE IN MILLIMETERS.
  - SCALE AS MENTIONED.
  - ALL WALLS TO BE BUILT IN 225mm THICK BRICK.
  - PLEASE NOTE THAT THE PREVAILING SOIL CONDITIONS AT SITE ARE NOT CONSIDERED. PRIOR TO CONSTRUCTION, ENSURE IT'S SUITABLE FOR THE FOUNDATION DESIGN.
  - ALL BATH ROOM WALLS LINING UP TO 1800mm WITH 300000hrs GLAZED CERAMIC WALL TILES. BATH ROOM FLOORS LINING WITH 200x200mm NON-SLIP GLAZED CERAMIC FLOOR TILES.
  - ALL FLOOR AREA EXCEPT VERANDAH & GARAGE LINING WITH NON-SLIP GLAZED CERAMIC FLOOR TILES.
  - SIZE OF TIMBER BEAMS & PROPS FOR THE ROOF AS PER THE RECOMMENDATION OF THE ENGINEER.
  - CAPACITY OF 2000 LITERS WATER TANK (PLASTIC) TO BE INSTALLED ON THE BATH ROOM TOP SLAB AS SHOWN IN THE FRONT VIEW.
  - DELIVERY LINE SHOULD BE CONNECTED THROUGH A BOOSTER PUMP.

DEMOCRATIC SOCIALIST REPUBLIC OF SRI LANKA  
MINISTRY OF PORTS AND HIGHWAYS  
**JP** Road Development Authority

NO.	REVISION	DATE

SOUTHERN TRANSPORT DEVELOPMENT PROJECT  
FUNDED BY EXPORT IMPORT BANK OF CHINA  
SECTION: PINNADUWA TO MATARA  
  
ACCOMMODATION - TYPE A

DESIGNED BY:	
DRAWN BY:	
APPROVED BY:	
DWG. NO.	SSSP/DRG/TYPE 'A' - 3

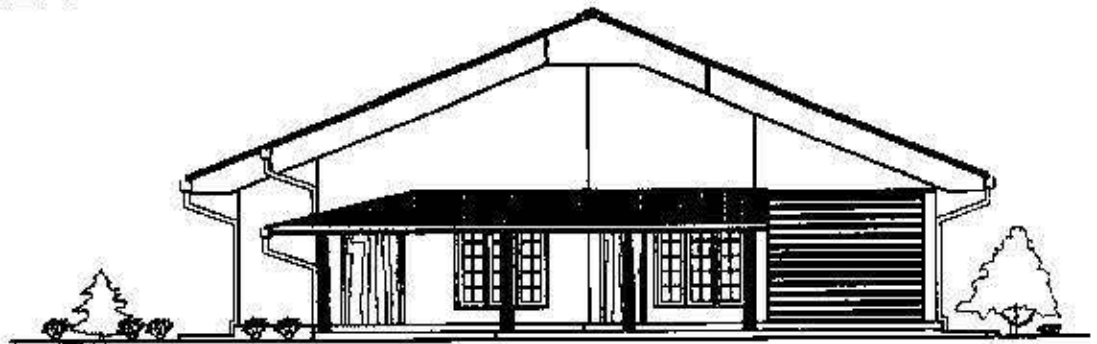

**FRONT VIEW**  
SCALE 1:100

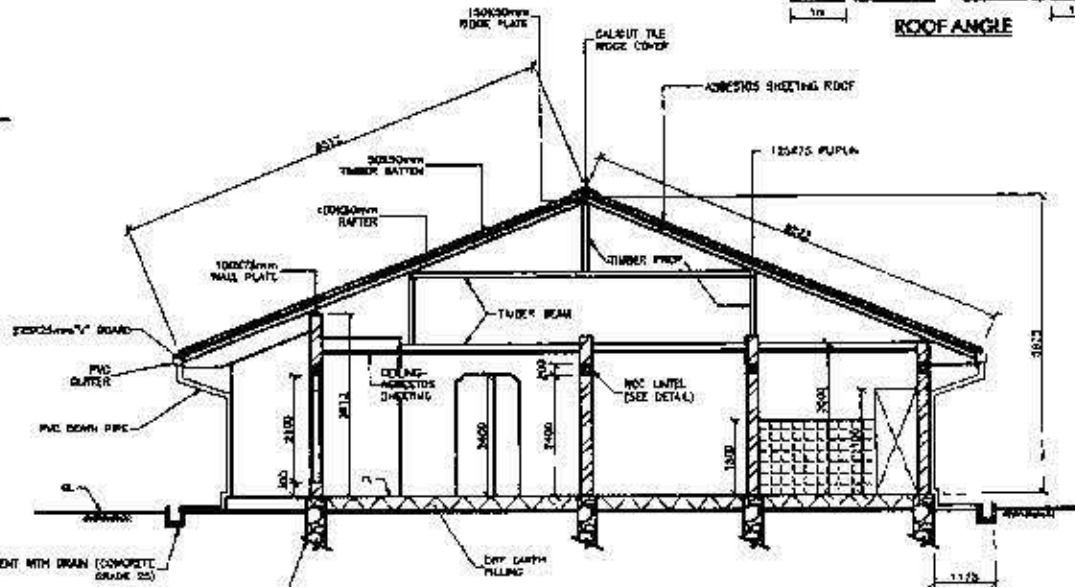
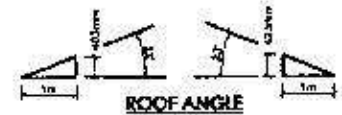

**SECTION A-A**  
SCALE 1:100

**Notes:**

1. ALL DIMENSIONS ARE IN MILLIMETRES.
2. SCALE AS MENTIONED
3. ALL WALLS TO BE BUILT IN 200mm THICK BRICK
4. PLEASE NOTE THAT THE PREVAILING SOIL CONDITIONS AT SITE ARE NOT CONSIDERED. PRIOR TO CONSTRUCTION ENSURE IT'S SUITABILITY FOR THE FOUNDATION DESIGN.
5. ALL BATH ROOM WALLS LINING UP TO 1500mm WITH 200x200mm GLAZED CERAMIC WALL TILES
6. BATH ROOM FLOORS LINING WITH 200x200mm NON-SLIP GLAZED CERAMIC FLOOR TILES.
7. ALL FLOOR AREA EXCEPT VERANDAH & GARAGE LINING WITH NON-SLIP GLAZED CERAMIC FLOOR TILES.
8. SIZE OF TIMBER BEAMS & PROPS FOR THE ROOF AS PER THE RECOMMENDATION OF THE ENGINEER.

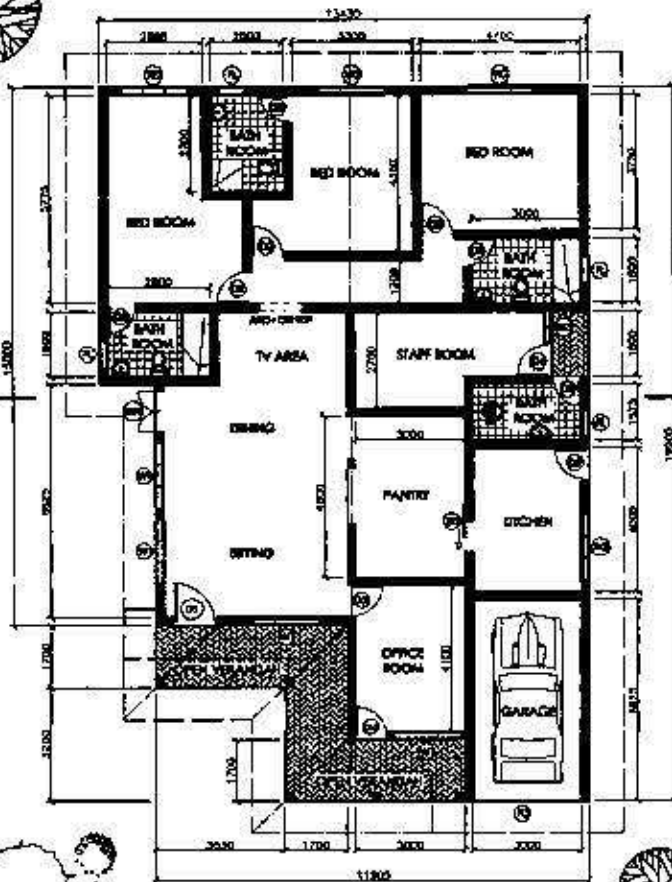

**FLOOR PLAN**  
NOT TO SCALE

DEMOCRATIC SOCIALIST REPUBLIC OF SRI LANKA  
MINISTRY OF PORTS AND HIGHWAYS  
**Road Development Authority**

SOUTHERN EXPRESSWAY EXTENSION PROJECT  
FROM MATARA TO HAMBANTOTA  
FUNDED BY EXPORT IMPORT BANK OF CHINA

ACCOMMODATION - TYPE B

DESIGNED BY:	
CHECKED BY:	
APPROVED BY:	
ENGL. NO.	REP-DRG-ACC-TYPE B-4
	SHEET 1 OF 2

NO.	REVISION	DATE

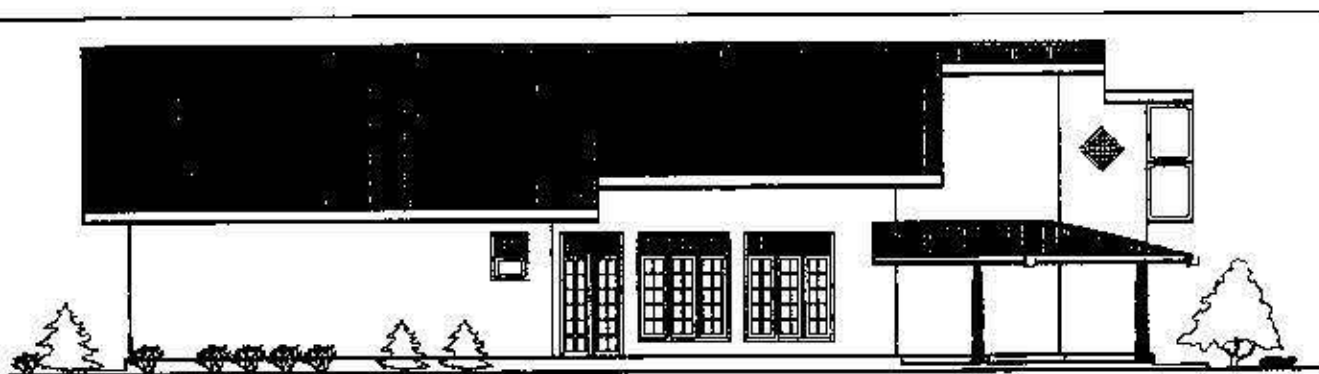

**SIDE VIEW**  
SCALE 1:100

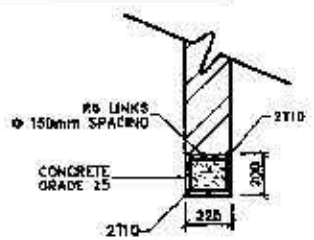

**DETAIL OF RCC LINTEL**  
SCALE 1:25

SCHEDULE OF DOORS & WINDOWS			
TYPE	SIZE	DESCRIPTION	NO.
D1	1200x2400	RUSH PANELED DOOR WITH SLATS ON TOP	01
D2	1900x1100	PLYWOOD DOOR	05
D3	800x2100	DOOR	04
D4	1900x1100	PLYWOOD DOOR WITH SLATS ON TOP	02
DW	1200x1400	SCOTCH TYPE DOOR WINDOW WITH SLATS ON TOP	01
D5	1900x2100	ALUMINIUM FRAMED GLAZED SLIDING DOOR	01
FD	3000x2400	ALUMINIUM ROLLER SHUTTER DOOR	01
W1	1800x2100	SCOTCH TYPE WINDOW WITH SLATS ON TOP	04
W2	1800x1800	DOOR	04
W3	1900x2100	DOOR	01
FL	1900x1100	GLAZED FAUCIANT WITH SLATS ON TOP	04

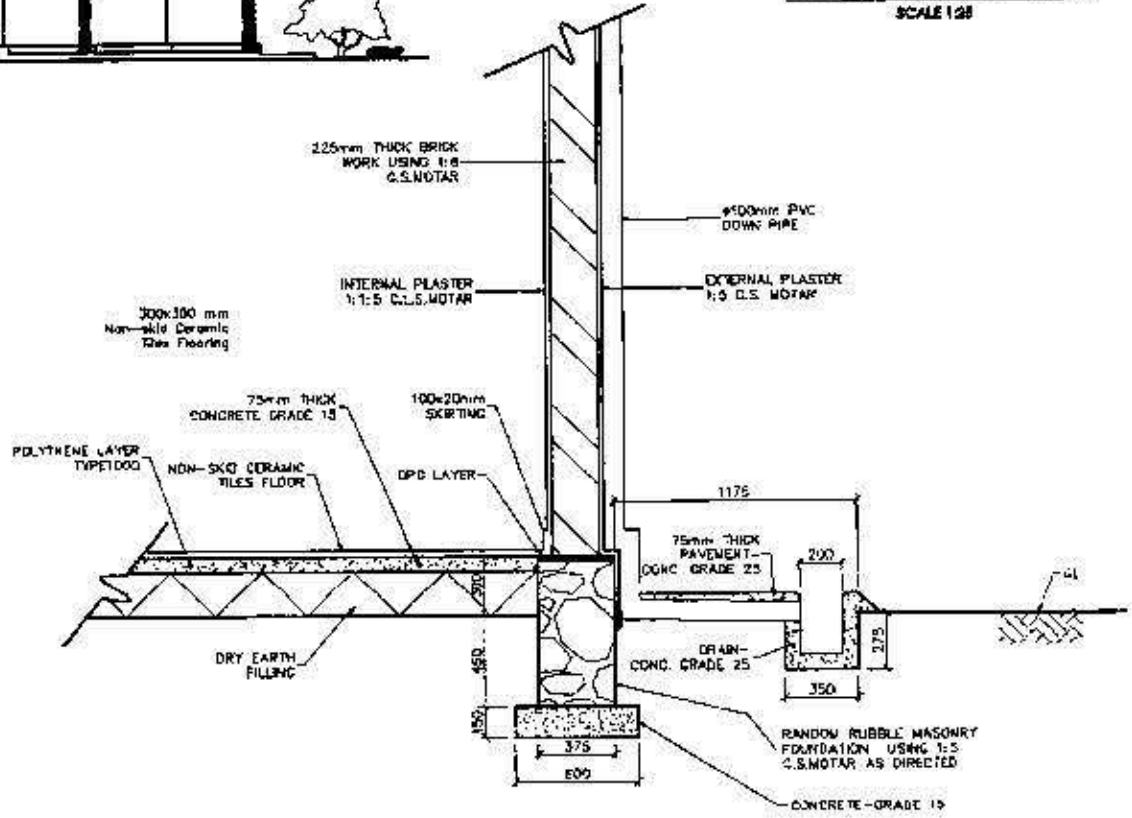

**DETAIL OF FOUNDATION**  
SCALE 1:25

(THE FDN. DESIGN CAN BE CHANGED ON THE PREVAILING SOIL CONDITIONS AT SITE)

- Notes:**
1. ALL DIMENSIONS ARE IN MILLIMETERS.
  2. SCALE AS MENTIONED
  3. ALL WALLS TO BE BUILT IN 225mm THICK BRICK
  4. PLEASE NOTE THAT THE PREVAILING SOIL CONDITIONS AT SITE ARE NOT CONSIDERED, PRIOR TO CONSTRUCTION, ENSURE ITS SUITABILITY FOR THE FOUNDATION DESIGN.
  5. ALL BATH ROOM WALLS LINING UP TO 1.800m WITH 200x200mm GLAZED CERAMIC WALL TILES
  6. ALL BATH ROOM FLOORS LINING WITH 200x200mm NON-SLIP GLAZED CERAMIC FLOOR TILES.
  7. ALL FLOOR AREA EXCEPT VERANDAH & GARAGE LINING WITH NON-SLIP GLAZED CERAMIC FLOOR TILES.
  8. SETS OF TIMBER BEAMS & PROPS FOR THE ROOF AS PER THE RECOMMENDATION OF THE ENGINEER.

DEMOCRATIC SOCIALIST REPUBLIC OF SRI LANKA  
MINISTRY OF PORTS AND HIGHWAYS  
Road Development Authority

SOUTHERN EXPRESSWAY EXTENSION PROJECT  
FROM MATARA TO HAMBANTOTA  
FUNDED BY EXPORT IMPORT BANK OF CHINA

ACCOMMODATION - TYPE B

DESIGNED BY:	
CHECKED BY:	
APPROVED BY:	
DWG. NO.	SEP-BRC-ACC-TYPEB-1
SHEET 2 OF 2	

REVISION DATE



**APPENDIX - 4**

**VEHICLES FOR THE ENGINEER AND EMPLOYER**

Vehicles shall be provided in accordance with the following schedules.

**For the Engineer:**

VEHICLE TYPE	BASIC SPECIFICATION
Type 1A	4 wheel drive Jeep, 2000cc (minimum) diesel engine, air conditioned, 4 seats, 5 speed transmission with high/low ratio transfer gear, reverse camera 4 door with cover to load platform.
Type 1B	4 wheel drive double cab pickup, 1800cc (minimum) diesel engine, air conditioned, 4 seats, 5 speed transmission with high/low ratio transfer gear, 4 door with cover to load platform.
Type 2	1500cc (minimum) Petrol saloon Car, air conditioned, 4 seats, 5 speed transmission, driver and passenger airbags, 4 doors, reverse camera
Type 3	2 wheel drive passenger van, 2000cc (minimum) diesel engine, air conditioned, 9 seats (minimum), 4 doors.
Type 4	150cc four stroke petrol engine motorcycle

**For the Employer:**

VEHICLE TYPE	BASIC SPECIFICATION
Type 1A	4 wheel drive Jeep, 2000cc (minimum) diesel engine, air conditioned, 4 seats, 5 speed transmission with high/low ratio transfer gear, reverse camera, 4 door with cover to load platform.
Type 2	1500cc (minimum) Petrol Saloon Car, air conditioned, 4 seats, 5 speed transmission, driver and passenger airbags, reverse camera, 4 doors.

## APPENDIX - 5

### LABORATORIES FOR THE ENGINEER

#### 1. General

The Laboratory shall be furnished and maintained with all equipment, apparatus and supplies necessary to permit proper execution of all standard tests required by the Specifications. Lists of specific laboratory equipment described in the Specifications are intended as an aid to the Contractor and should not be construed as a binding list or as a recommendation to purchase from a specific manufacturer. The Contractor shall submit to the Client for his approval, a complete listing of the equipment, apparatus and supplies available in the laboratory.

The quality control of materials used in road construction projects requires specialized test equipment. The laboratories shall be equipped with all necessary test equipment to control the materials to be used on the Project. The test equipment shall be in good condition and calibrated in accordance with the requirements of standards and testing specifications.

The Contractor shall provide all equipment needed for the correct execution of the test according to the AASHTO, ASTM, BS and SLS standards mentioned. The equipment shall be of an acceptable quality approved by the Engineer.

#### 2. List of Laboratory Equipment

The following listing of test equipment is given as a check list of likely required items and is related to the construction control specified for the Project. The equipment listed and the number of individual items is a minimum requirement. Many of the items are easily broken or otherwise rendered unusable and replacement shall be readily available, so that the control testing of critical construction is not interrupted. On completion of the Works the laboratory equipment shall be handed over to the Employer.

#### 3. Asphalt Laboratory

The Specifications state that all asphalt delivered must have the supplier's test certificate giving the parameters of the asphalt. Failure to produce these certificates may mean that the Contractor has to test the asphalt at his own expense. This test could also be required on any disputed asphalt. The asphalt tests which may be required are as follows:

- a) Softening point
- b) Ductility
- c) Loss on heating
- d) Drop in penetration after heating
- e) Solubility in carbon disulphide
- f) Ash content
- g) Specific gravity
- h) Penetration

The laboratory equipment provided by the Contractor for testing of Asphaltic materials and mixtures is at the discretion of the Contractor but given the limited properties of Asphalt involved in the project, appropriate external sources may be sought.

Asphalt Mix Design by the Marshall Method has to be carried out in the laboratory prior to getting approval for the mix design. Re-checking the mix design several times would be necessary. Further new mix designs are called for where the quality of aggregate changes.

The laboratories for the Engineer shall be provided, furnished and equipped in accordance with the following schedules.

### Main Laboratory

	DESCRIPTION	Compliance	No.
	<b>A. Main Laboratory</b>		
	Laboratory of gross floor area 200sq.m. located adjacent to the Resident Engineers Office with area divided into a) office, b) soils and materials lab, c) concrete lab, d) bitumen lab, and where required e) asphalt lab.		1
	Bathroom		1
	Kitchen		1
	Storeroom		1
	<b>B. Furnishings and Equipment</b>		
	Office desks 120x70cm and each having at least 3 drawers, one of which is lockable.		4
	Computer desks.		2
	Typist chairs, gas lift height adjustment, arm rests.		6
	Bench Stools		6
	Steel filing cabinets with four drawers.		2
	Book shelves, 1m.x 2m. with 3 shelves and lockable cupboard at base.		1
	Storage cabinets 1mx2m, two door, lockable.		1
	Laboratory benches sufficient for all testing equipment		As reqd.
	Laboratory sinks with cold tap (minimum)		2
	Bulletin board 0.9x0.6m.		1
	White marker board 1.2mx0.8m.		1

BS 2

	Laptop Computers, Intel® Core™ i7 (620M) Processor, 15.6" HD Anti- Glare LED Display (1600x900), 4GB DDR3 RAM up to 16 GB, 500GB HDD, DVD+/-RW DL, PCMCIA slot, , Integrated modem, 4xUSB 2.0 ports, integrated wireless LAN, Network slot and 3 in 1 card reader, licensed Windows 7 professional or latest version, Kaspersky Internet Security new version, Optical Mouse, 3 Years comprehensive warranty.		4
	Uninterrupted Power Supply, On line Unit 1 kVA with sealed maintenance free battery and 60 minutes backup time.		2
	Laptop Computers, Intel® Core™ i7 (620M) Processor, 15.6" HD Anti- Glare LED Display (1600x900), 4GB DDR3 RAM up to 16 GB, 500GB HDD, DVD+/-RW DL, PCMCIA slot, Integrated modem, 4xUSB 2.0 ports, integrated wireless LAN, Network slot and 3 in 1 card reader, licensed Windows 7 professional or latest version, Kaspersky Internet Security new version, Optical Mouse, 3 Years comprehensive warranty.		2
	A4 laser jet printer with hub		1
	<b>C. Safety Equipment</b>		
	Safety helmets.		6
	Water/ windproof jacket and over trousers.		6
	Motorcycle crash helmets.		4
	Fire extinguishers - one per room		7
	First aid box – stocked.		1
	<b>A- General laboratory Equipment</b>		
1	Geographic Positioning System (GPS) Hand held		1
2	Rubber mallet (large)		6
3	Rubber mallet (medium)		6
4	Steel Scoops or aluminum (1000ml)		6
5	Steel Scoops or aluminum (2000ml)		6
6	Flasks 100ml (plastic)		3
7	Flasks 100ml (glass -Pyrex)		3
8	Flasks 250ml (plastic)		3
9	Flasks 250ml(glass -Pyrex)	AASHTO/ASTM	3
10	Flasks 500ml (plastic)		3
11	Flasks 500ml(glass -Pyrex)	AASHTO/ASTM	3
12	Flasks 1000ml (plastic)		4
13	Flasks 1000ml(glass -Pyrex)	AASHTO/ASTM	3
14	Measuring cylinders 1000ml (plastic)		4
15	Measuring cylinders 1000ml(glass -Pyrex)	AASHTO/ASTM	2
16	Measuring cylinders 500ml (plastic)		3
17	Measuring cylinders 500ml(glass -Pyrex)	AASHTO/ASTM	2
18	Measuring cylinders 250ml (plastic)		2

*Handwritten signature or initials*

19	Measuring cylinders 250ml(glass -Pyrex)	AASHTO/ASTM	2
20	Measuring cylinders 100ml (plastic)		2
21	Measuring cylinders 100ml(glass -Pyrex)	AASHTO/ASTM	2
22	Beakers with spout 1000ml (plastic)		4
23	Beakers with spout 1000ml (glass -Pyrex)	AASHTO/ASTM	2
24	Beakers with spout 500ml (plastic)	AASHTO/ASTM	4
25	Beakers with spout 500ml(glass -Pyrex)	AASHTO/ASTM	4
26	Beakers with spout 250ml (plastic)		3
27	Beakers with spout 250ml (glass-Pyrex)	AASHTO/ASTM	3
28	Volumetric flask 250ml (glass Pyrex)		4
29	Volumetric flask 500ml(glass -Pyrex)	AASHTO/ASTM	4
30	Volumetric flask 1000ml(glass -Pyrex)		2
31	GI Drying pans with handle (two side) 400x400x75mm deep		25
32	GI Drying pans with handle (two side) 600x600x75mm deep		25
33	GI Drying pans (water proof) 250x250x60mm deep		60
34	GI Drying pans with handle (four side)1000x1000x100mm deep		8
35	Ceramic coated enamel Trays 300 X 215 X 60 mm		12
36	Ceramic coated enamel Trays 420 X 310 X 60 mm		12
37	Aluminum Trays 400x 260 X 50 mm		6
38	Aluminum moisture content cans 60 (dia) mmx50mm with lids		100
39	Aluminum moisture content cans 130 (dia) mmx 80 mm with lids		70
40	Stainless steel bowl 2.5 lt.		5
41	Stainless steel bowl 1.0 lt.		5
42	Air tight restless container (tin) 5 lt.		25
43	Metal base laboratory stands with variable size plastic and metal clamps		2
44	Asbestos hand gloves heat resistant (pair)		3
45	Laboratory tong		3
46	Stainless steel Spatulas 150mm long	AASHTO/ASTM	5
47	Spatulas 75mm long		5
48	Plastic wash bottle (750ml)		5
49	Hot plates 400X300 mm 1500w		1
50	Set of Crow Bar Pick axe Spade (Shovel) and Mammoty		3
51	Set of Claw hammer, pliers , Mason trowel		1

BS 8



52	Set of spanners sizes varies (2mm to 20mm) made with vanadium		1
53	Set of Screwdrivers (3" to 12") steel		1
54	Set of Screwdrivers (small 1mm 6mm flat and tri-wing)		1
55	Set of allen key 1.5mm to 12mm		1
56	Electronic stop watch	BS	3
57	Venire Calipers (Electronic with digital display) Range: 0-150mm x 0.02mm and 0-300 mm x 0.02mm	BS	2
58	Micrometer 0-100mm (electronic with digital display)	BS	1
59	Steel Ruler - 300mm		6
60	Steel measuring tape		2
61	Linen measuring tape		2
62	Glass Thermometer (mercury) suitable for general laboratory use. Temperature range: 0 °C to 250 °C	AASHTO/ASTM	3
63	Glass Thermometer (mercury) suitable for general laboratory use. Temperature range: -10 °C to 50 °C	AASHTO/ASTM	3
64	Glass Thermometer (mercury) suitable for general laboratory use. Temperature range: 10 °C to 350 °C	AASHTO/ASTM	3
65	Electronic digital thermometer 0-200 <sup>o</sup> c 0.5/0.1 precision (pocket type)	AASHTO/ASTM	8
66	Electronic digital thermometer 0-250 C with probe 0.5/0.1 precision	AASHTO/ASTM	6
67	Infra red thermometer range 0 - 300 °c	AASHTO/ASTM	1
68	Dial thermometer 0-250 <sup>o</sup> c with 1.0 m long stem	AASHTO/ASTM	2
69	wheel barrow		2
70	3m long Straight Edge)		3
71	Camber boards to which necessary percentages		3
72	Set of Providing of all necessary consumables, Chemicals, normal cloth hand gloves, filter papers		10
<b>B. LAB EQUIPMENT FOR SOIL AND FIELD TEST</b>			
73	200 Liter with interior fan circulation, Stainless steel Oven with thermostatically controlled, Ideal for Drying and Moisture determination. External Dimension (mm) - 760 x 620 x 662, Temperature with digital display Range - 40-200 <sup>o</sup> c	ASTM/BS	5
74	Microwave Oven 18 lt digital display with necessary accessories		2

*Handwritten signature/initials*

75	Electronic portable Scale capacity 30/32kg 1.0g precession with chargeable battery		8
76	Electronic portable Scale capacity 15kg 1.0g precession with chargeable battery (Buoyancy- capable of getting weight in water)		6
77	Electronic portable Scale capacity 15kg 1.0g precession with chargeable battery		4
78	Electronic portable Scale capacity 6kg .1g precession with chargeable battery (Buoyancy -capable of getting weight in water)		4
79	Electronic portable Scale capacity 6kg 0.1g precession with chargeable battery		3
80	Electronic portable Scale capacity 0.3kg 0.01g precession with chargeable battery (wind shield )		2
81	Digital Analytical balance 200g precision 0.0001g		1
82	Ground glass Plate 400 x 600 x 6mm		3
83	Linear Shrinkage Mould (consisting of 3 mould ) set Made of brass, semicircular section, radius 12.5mm x 150mm long. Measurement in length of the soil sample is the "linear shrinkage".		2
84	Porcelain Mortar and rubber head Pestle 175mm diameter	AASHTO/ASTM	3
85	Sand Pouring Cylinder 200mm dia * 200mm Sand Pouring Cylinder with rotary shutter valve and handle. * 200mm Calibrating Container, 200mm inside diameter x 250mm depth with 350mm diameter outside rim. * Metal Tray, 500mm square x 50mm depth with central hole 200mm diameter.	BS	8
86	3 kg LP Gas cylinders (small Size)		4
87	Single Burner with self ignition switch		6
88	Complete set of accessories for field density test		6
89	Plastic heavy duty bucket with lid 10 lt		6
90	Plastic heavy duty bucket with lid 10 - 12 lt		6
91	Plastic pale (bucket) with lid 30-40 lt		4
92	Hydrostatic weighing table and its necessary accessories specific gravity of coarse aggregate BS 812/ASTM C 127	AASHTO/ASTM/ BS	1
93	Specific gravity set consist of Sand Absorption Cone and tamper, wire basket for sample with tamping rod and glass pycnometer as per ASTM C 128	AASHTO/ASTM/ BS	2
94	Wire basket 200 dia mmX 200 height 3.35mm mesh		2

DR A

95	Bulk Density Measure 30L Capacity	AASHTO/ASTM/ BS	1
96	Bulk Density Measure 7L Capacity	AASHTO/ASTM/ BS	1
97	Automatic CBR/Proctor compactor rammer diameter 50.8mm and weight is interchangeable from 2.49kg to 4.54kg,height of rammer drop is adjustable from 304.8mm to 457.2mm	AASHTO/ASTM/ BS	2
98	50 kN computerized machine suitable for the determination of the laboratory CBR with all necessary fittings , with digital display and monitor (including software )	AASHTO/ASTM	2
99	Motorized 50kN CBR Test Machine, bench mounted with digital read out variable speed 50.8mm,1.27mm,1.0mm per min, for marshall and CBR of ASTM AND BS specimen test Fast platen adjustment for Forward / Reverse Load ring of range 0 to 10kN soil CBR test machine Load ring of range 0 to 50kN for Marshal / CBR test machine	AASHTO/ASTM	2
100	AASHTO/ASTM CBR Mould body 152mm diameter x 127mm (H) Wing Nuts Type, with extension collar 152mm diameter x 51mm (H) and perforated base plate. Swell Tripod to fixed dial gauge with in position on CBR mould Dial gauge, 57mm diameter, 25mm Travel x 0.01mm resolution (set)	AASHTO/ASTM	60
101	Solid base plate for CBR Moulds AASHTO/ASTM	AASHTO/ASTM	10
102	Surcharge weight 2.27kg Ring Type AASHTO/ASTM	AASHTO/ASTM	60
103	Surcharge weight 2.27 kg Slotted Type AASHTO/ASTM	AASHTO/ASTM	60
104	Spacer disc for above		10
105	Fiberglass soaking tank for 21nos of CBR Moulds		3
106	S 27 Sand Pouring Cylinder * 150mm Sand Pouring Cylinder with rotary shutter valve. * 150mm Calibrating Container, 150mm inside diameter x 50mm depth with 250mm diameter outside rim. * Metal Tray, 300mm square x 40mm depth with hole 150mm diameter.	BS	2
107	AASHTO/ASTM Compaction Rammer 2.5kg weight(standard)	AASHTO/ASTM	2
108	AASHTO/ASTM Compaction Rammer 4.5kg weight(modified)	AASHTO/ASTM	8
109	AASHTO/ASTM Standard Compaction Mould, with extension collar and base plate.	AASHTO/ASTM	2
110	AASHTO/ASTM Heavy duty modified Compaction mould, with extension collar and base plate.	AASHTO/ASTM	12

Q1 A

111	Hand Operated universal extruder for 35 mm to 152.4 mm dia compaction (proctor) ,CBR and Marshall with accessories for extruding same samples	AASHTO/ASTM	4
112	Straight edge for cut off excess soil in compacted CBR and compaction mould		10
113	Riffle box 50mm stainless steel slot width, 8 nos of slots and complete with 3 nos of galvanized tray	AASHTO/ASTM	3
114	Riffle box 12mm stainless steel slot width, 12 nos of slots and complete with 3 nos of galvanized tray	AASHTO/ASTM	2
115	Wet Washing Sieve Made of Stainless Steel, dimension is 200mm dia. X 200mm (H) with aperture size 75 micron.	BS	10
116	Test Sieves - Made of Stainless Steel, standard diameter of 200mm and chromed steel perforated mesh 75mm,63mm,50mm,37.5mm,28mm, 20mm, 14mm, 10mm, 9.5mm, 6.3mm, 5.0mm,4.75, 3.35mm, 2.36mm, 2.0mm, 1.7mm, 1.18mm,0.6mm,0.475mm,0.3mm,0.15mm,.075mm 0.600mm, 0.425mm, 0.300mm, 0.150mm, 0.075mm(one set consist of 27 nos. sieves) and lid and pan	BS	5
117	Test Sieves - Made of Stainless Steel, standard diameter of 300mm and chromed steel perforated mesh 75mm,63mm,50mm,37.5mm,28mm, 20mm, 14mm, 10mm, 9.5mm, 6.3mm, 5.0mm,4.75, 3.35mm, 2.36mm, 2.0mm, 1.7mm, 1.18mm,0.6mm,0.475mm,0.3mm,0.15mm,.075mm 0.600mm, 0.425mm, 0.300mm, 0.150mm, 0.075mm(one set consist of 27 nos. sieves) and lid and pan	BS	3
118	Test Sieves - Made of Stainless Steel, standard diameter of 450mm and chromed steel perforated mesh 75mm,63mm,50mm,37.5mm,28mm, 20mm, 14mm, 10mm, 9.5mm, 6.3mm, 5.0mm,4.75 mm (one set consist of 12 nos. sieves) and lid and pan	BS	2
119	Test Sieves - Made of Stainless Steel, standard diameter of 300mm and chromed steel perforated mesh 3 in,2 1/2 in,2 in ,1 1/2 in,1 in, 3/4 in ,1/2 in 3/8 in ,1/4 in ,#4, #8 ,#16 ,#30 ,#50 ,#100 ,#200 (one set consist of 16 nos. sieves) and lid and pan	AASHTO/ASTM	1
120	Casagrande Liquid Limit Device With hard adjustable rubber base fixed with removable brass cup with dropping height according to the standard requirement. A built-in blow counter.	AASHTO/ASTM	2

BN A

121	Motorized Casagrande Liquid Limit Device adjustable rubber base fixed with removable brass cup with dropping height according to the standard requirement. A built-in blow counter,	AASHTO/ASTM	2
122	AASHTO Grooving tool for above	AASHTO	5
123	Semi automatic electrical operated cone penetrometer for liquid limit test	AASHTO/ASTM	2
124	Glass plate 600 X 400 mm thickness >6mm		3
125	Glass Desiccators with vacuum tap on the cover (300mm dia, vacuum)		1
126	Gas jar 2lt with glass plate and rubber bung	BS	3
127	Soil Hydrometer Glass made with range 0.995 to 1.038g/ml.	AASHTO/ASTM	2
128	Sand Equivalent Apparatus Complete with 4nos graduated plastic cylinder, rubber stopper, irrigator tube, weighted foot assembly, siphon assembly, rubber tubing, measuring tin, funnel and bottle special concentrated solution (250ml). Come with wooden case. (ASTM). Motorized Mechanical Sand Equivalent Shaker. This unit is made for bench mounting, built-in counter for setting number of cycles, accordance to ASTM requirement.	AASHTO/ASTM	2
129	100mm dia Cohesive Manual Soil Auger 3m long rod (set) & T handle		2
130	Mackintosh & Mackintosh Prospecting Kit This portable equipment is capable of prospecting to depth of 15 meter, depending on ground conditions. The kit comprises 13 nos. penetration rods of 1.2m long, 13 nos. coupler, 2-pipe wrenches, 2 nos. driving cone head 30 , 1 no. hammer, 2 nos. hammer nuts, 1 no. lifting tool and 1 no. wooden carrying case.		2
131	76100000 - A2465° - DYNAMIC CONE PENETROMETER (D.C.P.) TRL Specification D.C.P. Complete with wooden carrying case.		3
132	Chloride content kit for sand and fine aggregate	BS	1
133	Specific gravity glass bottle with glass stopper (100,50,25ml) set	BS	3
134	Set organic impurities in fine aggregate	BS	2
135	Electronic pH meter	BS	2
136	Speedy Moisture Tester D 2 large 0 - 20%		1
137	Speedy Moisture Tester D 2 small 0 - 20%		1
138	Dissolved Oxygen Meter		1
139	Crack detection microscope, Magnification X 35, measuring range of 4 mm in 0.02mm division		

*Handwritten signature*



	<b>C . Concrete Testing Equipments</b>		
140	Electrically Operated Automatic Machine with digital readout with printer., capacity 2000 kN Concrete Compression Testing Machine travel distance should be more than 315mm with necessary platen for cube and cylinders 100 & 150 mm including standard distance pieces 4 nos.	BS	3
141	Platform Balance with digital display capacity 100kg precision 5 or 10g		2
142	portable concrete mixer for trial mix vertical drum	BS	2
143	Vibrating table for casting concrete cubes ,300 x 1500mm	BS	2
144	Steel cube mould with clamp, base plate and 150mm x150mm side	BS	120
145	Tamping (compacting) bar as BS standard	BS	10
146	Tools (spanners and wrenches) for demolding above		10
147	Heavy duty plastic cube mould with properly fixed valve ,internal dimension 150 X 150 X 150 mm which is capable of demolding with compress air using air compressor	BS	500
148	Air compressor for above 0.5hp		2
149	Curing Tank for test cubes decided at laboratory location (3.5 X 2.0 X 0.6 mm)		2
150	Slump Cone with funnel The set cone with tamping rod and base plate. Manufactured from sheet steel with paint protected. (Slump cone, Metal Tray 600mm x 600mm x 80mm, Tamping rod 16mm dia x 600mm , Steel rule 300mm long)	BS	10
	<b>D. Cement test</b>		
151	70.7mm Cube mould complete with base plate		30
152	Vibrating Machine for 70.7 mm cube mould 220 240v 50Hz 1ph		1
153	Blaine Air permeability Apparatus		1
154	Sundness of portland cement by the Autoclave method ASTM C 151		1
155	Sundness of cement paste Le chatelier ethod EN 193 3 Le chatelier mould with glass plates		12
156	Le chatelier water bath		2
157	EN Extensibility Apparatus		1

*BS*

158	Vacuum pump 220 - 240 v 50/60 Hz 1ph		1
159	Vicat apparatus complete set with all necessary accessories including vicat mould (split cup),plunger,(needle for setting time) glass plates	EN 196 -3	2
160	Non Destructive concrete test hammer (schmid Hammer) complete set with abration stone	BS	2
E. Bitumen Testing Equipments			
161	Penetrometer Apparatus consist of dial gauge indicator 25mm x 0.01mm per division, with penetration needle. Test gauge for needle Penetration cups & Transfer dish (set)	ASTM	2
162	Gooch crucible 44mm dia at the top tapering to 36 mm at bottom with necessary accessories to success the test including glass wool filter flask ,filter tube ,Erlenmeyer flask 125ml	ASTM	10
163	Carbon Disulphide 500ml		5
164	Trichloroethylene 500ml		5
165	Ring and Ball Apparatus (Manual) ASTM D36 but this manual simple apparatus developed as the temperature of bitumen raised, the softness of it increased. The set consists of a beaker, frame, two tapcred rings, two balls and centering guides. The apparatus must complete with some accessories to success the test. Supplied All accessories.	AASHTO/ASTM	3
166	Ductilometer ASTM D113 For determination of bituminous ductility, which means, distance to which a briquette of molten bitumen can be extended under controlled condition, before breaking. The set consists of a moving carriage traveling along guide ways. The large long tank fitted with thermostat, heater, cooling coil for cool water circulation and pump. The carriage is driven by an electrical motor. The set is fully automatic function with a uniform speed . Tank outer made from stainless steel with fiberglass insulation. Supplied with briquette mould and base plate. Power: 220-240V, 50Hz, 1ph	AASHTO/ASTM	1

*DS*

167	<p>Asphalt Oven BS2000, ASTM D6, ASTM D1754</p> <p>Asphalt oven with rotating shelf, temperature controlled by digital thermoregulatory. Shelf rotate at 5rpm. The unit supplied without shelf, container and others accessories that have to ordered separately. Power: 220-240V, 50Hz, 1ph Dimension (Internal): 335 x 335 x 335mm approx. Weight: 40kg approx.</p> <p>Accessories: Rotating shelf with 9 containers size,55mm dia x 35mm (H) fitted Comply to BS 2000 and ASTM D6 standard "Determination of Loss On Heating".</p>	AASHTO/ASTM	1
168	Cleaverland flash tester consist with brass cup mounted on an electric heater with temperature controller supplied with necessary accessories to implement the test correctly including thermometer	AASHTO/ASTM	1
169	Trays for rate of application test of binder 300 X 300 X 10 mm conforms to BS	BS	10
170	Set of 100 Nos. ( 100 X 50 X 1000 mm ) of suitable metal trays and a suitable trolley for Depot tray test as per BS standard	BS	1
171	Specific gravity bottle 100ml	BS	2
172	F. Asphalt Testing Equipments		
173	Automatic Marshall Compactor BS 598, ASTM D1559 Comprises of compactor hammer, hammer guide, mould clamp and laminated hardwood block.	AASHTO/ASTM	3
174	Marshall Mould with collar and base plate.	AASHTO/ASTM	54
175	50kN Computerised Marshall Test Machine with digital display and monitor accessories suitable to fix to the fram so as to work properly Stability mould (breaking head), open type made from steel with inside diameter of 4" to the dimension given in BS 598.	AASHTO/ASTM	2
176	<p>Water Bath</p> <p>23L Digital Readout Thermostatic Control Stainless Steel Water Bath fitted with stirrer for water circulation, cover, internal stainless steel constructed and outernal fitted with anti-heat protection fiber. Internal dimension (mm) - 350mm x 300mm x 220mm (h) , Controller - Digital, Temperature range (C) - 0 -100 c x 0.1 c, 240v 50Hz 1ph</p>	AASHTO/ASTM	3

*Handwritten signature/initials*

177	Centrifugal Asphalt Extraction Apparatus * Working voltage: AC220V 50HZ * Electricity machine: 250W * Governor deflection: 500~3000rotate/min * Specimen weight: 3000g * Stepless timing	AASHTO/ASTM	3
178	Filter papers for above conforms to ASTM ,AASHTO OR BS		500
179	Automatic Asphalt Binder Analyser) Asphalt ignition oven for bitumen ignition (extraction) of asphalt concrete with all accessories digital balance,sample basket,metal handle,metal safty cage etc.	EN12697-39	1
180	Mechanical mixture having a capacity of 2kg and a mixing bowl surrounded by a heating element with a suitable control.The mixer is to be suitably controlled .The mixer is to be suitable for mixing combined aggregates,filler,and binder speedily and throughly without the loss of fine material.A commercial bakers mixer equipped with a wire whisk of suitable and deattachable 10 liters mixing bowl is normally satisfactory providing 1.It will produce a well coated homogeneous mixture 2. it does not crush the aggregate and 3. It permit the complete removal of the whole batch to the mixture without disturbance of the mixture properties		1
181	Dichloromeththane 275 kg strengthened drum		1
182	Pavement core drilling machine SHP 4 - stroke petrol engine This rugged, compact and portable machine with vertical screw feed, is used for pavement core sampling where it is not easy to get electrical power. * Petrol engine 5HP power, 4 strock briggs & stratton model. * Dimensions 850 x 580 x 1230mm		1
183	Core barrel for above 100mm dia.		13
184	Core barrel for above 200 mm dia.		2
185	Set of jaws to hold the Marshall specimen with flow gauge including necessary bolt extention rod and fittings		1
186	Pycnometer for Maximum Theoretical specific gravity of asphalt concrete 10 It capacity plastic made 250mm dia,with valve and vacuum gauge supplied with necessary accessories		2

BS A

187	Vacuum pump for above with accessories		2
188	PSD (Percentage Refusal Density) steel mould split vertically 152 X 170mm	EN 12697-32	2
189	Kango Electric Hammer Compactor 230-240 v, 50Hz, single phase 800w (vibration hammer) with supporting frame and necessary foots including 150, 102, 146mm and shaft	BS 1377	1
190	Wire code for extension 10m length including 15A three core flexible wire with 13A, 5A square and round hole each plug base		2
	<b>G. Aggregate Testing Equipments</b>		
191	Motorized Test Sieve Shaker (200mm dia Sieves / 300mm dia Sieves) c/w timer control between 0-60 min, can accept up to 8nos of 200mm diameter sieve or 6nos of 300mm diameter sieve with lid and receiver. Power: 240V 50Hz 1pH	AASHTO/ASTM	1
192	Aggregate Impact Value Test (AIV) Apparatus complete set including standard test accessories for 14mm (sieves, metal cup, Measuring cup, rod etc. as per BS EN 1097-2=1998)	BS	2
193	Los Angeles Abrasion Machine meet ASTM C-131, C535, A T-96 including aberration chargers and necessary accessories AASHTO	AASHTO/ASTM	1
194	Flakiness Index Gauge to dimension specified in BS 812	BS	3
195	Apparatus for 10 percent fines value including standard mould body, detachable base plate, metal plunger, tamping rod and metal measure with all necessary accessories.	BS	2
	<b>H - Steel testing Equipments</b>		
196	600 kN Universal Testing Machine with As per UNI - EN - ISO 7500/1, piston stroke 400mm, specimen length 700mm maximum distance between tension heads (including piston travel): 915mm electrically operated lower head :500mm travel capable of carrying out tensile strength test on steel bars dia. 5 to 40mm provide with sets of grips for round bars diameters of 5-15, 15-32, 32-40 mm and grips for flat bars thicknesses of 0-22 and 22-42 mm and including compression plates dia, 105 & 215 with ball seating, flexural devices fixed load bearers with support rollers & articulated load bearer and bending devices complete set.	EN ISO 7500/1	1
<b>BORED CAST IN PLACE PILE FOR BRIDGES</b>			
	Test for support fluid (Bentonite)		

*Handwritten signature/initials*



197	Mud balance for density of support fluid	API RP 13	3
198	Marsh cone for Viscosity	API RP 13	3
199	Sand screen test apparatus for sand content	API RP 13	3
200	Electrical pH meter to BS 3145 range pH7 to 14 for pH	API RP 13	2
201	Fan viscometer for shear strength	API RP 13	2
202	Low temperature test for Fluid test	API RP 13	2
	SAFTY EQUIPMENT		
	Safty Helmets		12
	waterywindpooof jacket and over trousers		12
	First Aid box		2

The secondary laboratory for the Engineer shall be provided, furnished and equipped in accordance with the following schedule.

#### Secondary Laboratory

	<b>B. Secondary laboratory</b>		
	Laboratory of gross floor area 120 sq. m. located adjacent to the Secondary Office (Resident Engineer's Office)		1
	Bathroom		1
	Kitchen		1
	Store room		1
	<b>B. Furnishings and Equipment</b>		
	Office desks 120x70cm and each having at least 3 drawers, one of which is lockable.		2
	Computer desks.		1
	Typist chairs, gas lift height adjustment, arm rests.		6
	Bench Stools		6
	Steel filing cabinets with four drawers.		2
	Book shelves, 1m.x 2m. with 3 shelves and lockable cupboard at base.		1
	Storage cabinets 1mx2m, two door, lockable.		1
	Laboratory benches sufficient for all testing equipment		As reqd.

*Handwritten signature and initials*

	Laboratory sinks with cold tap (minimum)		2
	Bulletin board 0.9x0.6m.		1
	White marker board 1.2mx0.8m.		1
	IBM Compatible PC, 2.4Ghz processor, 256 Mb DDR RAM, 40Gb Hard Drive, DVD-CD /RW, Modem, 101 Key English Key Board, 2 x USB ports, VGA card, 17" flat screen monitor, Microsoft Mouse, with licensed MS Windows XP and MS Office Professional		1
	Uninterrupted Power Supply, On line unit 1 kVA with sealed maintenance free battery and 60 minutes backup time.		1
	A4 laser jet printer		1
	<b>C. Safety Equipment</b>		
	Safety helmets.		6
	Water/ windproof jacket and over trousers.		6
	Motorcycle crash helmets.		4
	Fire extinguishers - one per room		7
	First aid box – stocked.		1
	<b>A- General laboratory Equipment</b>		
1	Rubber mallet (large)		4
2	Rubber mallet (medium)		4
3	Steel Scoops or aluminum (1000ml)		4
4	Steel Scoops or aluminum (2000ml)		4
5	Flasks 100ml (plastic)		2
6	Flasks 100ml (glass -Pyrex)		2
7	Flasks 250ml (plastic)		2
8	Flasks 250ml(glass -Pyrex)	AASHTO/ASTM	2
9	Flasks 500ml (plastic)		2
10	Flasks 500ml(glass -Pyrex)	AASHTO/ASTM	2
11	Flasks 1000ml (plastic)		3
12	Flasks 1000ml(glass -Pyrex)	AASHTO/ASTM	2
13	Measuring cylinders 1000ml (plastic)		3
14	Measuring cylinders 1000ml(glass -Pyrex)	AASHTO/ASTM	2

*BS*

15	Measuring cylinders 500ml (plastic)		2
16	Measuring cylinders 500ml(glass -Pyrex)	AASHTO/ASTM	1
17	Measuring cylinders 250ml (plastic)		1
18	Measuring cylinders 250ml(glass -Pyrex)	AASHTO/ASTM	1
19	Measuring cylinders 100ml (plastic)		1
20	Measuring cylinders 100ml(glass -Pyrex)	AASHTO/ASTM	1
21	Beakers with spout 1000ml (plastic)		2
22	Beakers with spout 1000ml (glass -Pyrex)	AASHTO/ASTM	1
23	Beakers with spout 500ml (plastic)	AASHTO/ASTM	3
24	Beakers with spout 500ml(glass -Pyrex)	AASHTO/ASTM	2
25	Beakers with spout 250ml (plastic)		2
26	Beakers with spout 250ml (glass-Pyrex)	AASHTO/ASTM	1
27	Volumetric flask 250ml (glass Pyrex)		2
28	Volumetric flask 500ml(glass -Pyrex)	AASHTO/ASTM	2
29	Volumetric flask 1000ml(glass -Pyrex)		1
30	GI Drying pans with handle (two side) 400x400x75mm deep		20
31	GI Drying pans with handle (two side) 600x600x75mm deep		20
32	GI Drying pans (water proof) 250x250x60mm deep		60
33	GI Drying pans with handle (four side)1000x1000x100mm deep		5
34	Ceramic coated enamel Trays 300 X 215 X 60 mm		12
35	Ceramic coated enamel Trays 420 X 310 X 60 mm		12
36	Aluminum Trays 400x 260 X 50 mm		5
37	Aluminum moisture content cans 60 (dia) mm x50mm with lids		75
38	Aluminum moisture content cans 130 (dia) mm x 80 mm with lids		60
39	Stainless steel bowl 2.5 lt.		4
40	Stainless steel bowl 1.0 lt.		4
41	Air tight rustless container (tin) 5 lt		20
42	Metal base laboratory stands with variable size plastic and metal clamps		1
43	Asbestos hand gloves heat resistant (pair)		2
44	Laboratory tong		2
45	Stainless steel Spatulas 150mm long	AASHTO/ASTM	3
46	Spatulas 75mm long		3
47	Plastic wash bottle (750ml)		3
48	Hot plates 400X300 mm 1500w		1

BS A

49	Set of Crow Bar Pick axe Spade (Shovel) and Mamoty		2
50	Set of Claw hammer, pliers . Mason trowel		1
51	Set of spanners sizes varies (2mm to 20mm) made with vanadium		1
52	Set of Screwdrivers (3" to 12") steel		1
53	Set of Screwdrivers (small 1mm 6mm flat and tri-wing)		1
54	Set of allen key 1.5mm to 12mm		1
55	Electronic stop watch	BS	2
56	Venire Calipers (Electronic with digital display) Range: 0-150mm x 0.02mm and 0-300 mm x 0.02mm	BS	1
57	Micrometer 0-100mm (electronic with digital display)	BS	1
58	Steel Ruler - 300mm		4
59	Steel measuring tape		1
60	Linen measuring tape		1
61	Glass Thermometer (mercury) suitable for general laboratory use. Temperature range: 0 °C to 250 °C	AASHTO/ASTM	2
62	Glass Thermometer (mercury) suitable for general laboratory use. Temperature range: -10 °C to 50 °C	AASHTO/ASTM	2
63	Glass Thermometer (mercury) suitable for general laboratory use. Temperature range: 10 °C to 350 °C	AASHTO/ASTM	2
64	Electronic digital thermometer 0-200 <sup>o</sup> c 0.5/0.1 precision (pocket type)	AASHTO/ASTM	6
65	Electronic digital thermometer 0-250 C with probe 0.5/0.1 precision	AASHTO/ASTM	2
66	Infra red thermometer range 0 - 300 <sup>o</sup> c	AASHTO/ASTM	1
67	Dial thermometer 0-250 <sup>o</sup> c with 1.0 m long stem	AASHTO/ASTM	1
68	wheel barrow		2
69	3m long Straight Edge		1
70	Camber boards to which necessary percentages		1
<b>B. LAB EQUIPMENT FOR SOIL AND FIELD TEST</b>			
71	200 Liter with interior fan circulation, Stainless steel Oven with thermostatically controlled, Ideal for Drying and Moisture determination. External Dimension (mm) - 760 x 620 x 662, Temperature with digital display Range - 40-200 <sup>o</sup> c	ASTM/BS	3

BS A

72	Microwave Oven 18 lt digital display with necessary accessories		1
73	Electronic portable Scale capacity 30/32kg 1.0g precession with chargeable battery		4
74	Electronic portable Scale capacity 15kg 1.0g precession with chargeable battery (Buoyancy- capable of getting weight in water)		3
75	Electronic portable Scale capacity 15kg 1.0g precession with chargeable battery		2
76	Electronic portable Scale capacity 6kg .1g precession with chargeable battery (Buoyancy -capable of getting Wight in water)		3
77	Electronic portable Scale capacity 6kg 0.1g precession with chargeable battery(Buoyancy)		2
78	Electronic portable Scale capacity 0.3kg 0.01g precession with chargeable battery (wind shield )		2
79	Digital Analytical balance 200g precision 0.0001g		1
80	Ground glass Plate 400 x 600 x 6mm		2
81	Linear Shrinkage Mould (consisting of 3 mould ) set Made of brass, semicircular section, radius 12.5mm x 150mm long. Measurement in length of the soil sample is the "linear shrinkage".		1
82	Porcelain Mortar and rubber head Pestle 175mm diameter	AASHTO/ASTM	2
83	Sand Pouring Cylinder 200mm dia * 200mm Sand Pouring Cylinder with rotary shutter valve and handle. * 200mm Calibrating Container, 200mm inside diameter x 250mm depth with 350mm diameter outside rim. * Metal Tray, 500mm square x 50mm depth with central hole 200mm diameter.	BS	4
84	3 kg LP Gas cylinders (small Size)		4
85	Single Burner with self ignition switch		4
86	Complete set of accessories for field density test		4
87	Plastic heavy duty bucket with lid 10 lt		4
88	Plastic heavy duty bucket with lid 10 - 12 lt		4
89	Plastic pale (bucket) with lid 30-40 lt		2
90	Hydrostatic weighing table and its necessary accessories specific gravity of coarse aggregate BS 812/ASTM C 127	AASHTO/ASTM /BS	1
91	Specific gravity set consist of Sand Absorption Cone and tamper, wire basket for sample with tamping rod and glass pycnometer as per ASTM C 128	AASHTO/ASTM /BS	2

BS A

92	Wire basket 200 dia mmX 200 height 3.35mm mesh		1
93	Bulk Density Measure 30L Capacity	AASHTO/ASTM /BS	1
94	Bulk Density Measure 7L Capacity	AASHTO/ASTM /BS	1
95	Automatic CBR/Proctor compactor rammer diameter 50.8mm and weight is interchangeable from 2.49kg to 4.54kg,height of rammer drop is adjustable from 304.8mm to 457.2mm	AASHTO/ASTM /BS	1
96	50 kN computerized machine suitable for the determination of the laboratory CBR with all necessary fittings , with digital display and monitor (including software )	AASHTO/ASTM	1
97	Motorized 50kN CBR Test Machine, bench mounted with digital read out variable speed 50.8mm,1.27mm,1.0mm per min, for marshall and CBR of ASTM AND BS specimen test Fast platen adjustment for Forward / Reverse Load ring of range 0 to 10kN soil CBR test machine Load ring of range 0 to 50kN for Marshal / CBR test machine	AASHTO/ASTM	1
98	AASHTO/ASTM CBR Mould body 152mm diameter x 127mm (H) Wing Nuts Type, with extension collar 152mm diameter x 51mm (H) and perforated base plate. Swell Tripod to fixed dial gauge with in position on CBR mould Dial gauge, 57mm diameter, 25mm Travel x 0.01mm resolution (set)	AASHTO/ASTM	18
99	Solid base plate for CBR Moulds AASHTO/ASTM	AASHTO/ASTM	4
100	Surcharge weight 2.27kg Ring Type AASHTO/ASTM	AASHTO/ASTM	18
101	Surcharge weight 2.27 kg Slotted Type AASHTO/ASTM	AASHTO/ASTM	18
102	Spacer disc for above		4
103	Fiberglass soaking tank for 21 nos of CBR Moulds		1
104	S 27 Sand Pouring Cylinder * 150mm Sand Pouring Cylinder with rotary shutter valve. * 150mm Calibrating Container, 150mm inside diameter x 50mm depth with 250mm diameter outside rim. * Metal Tray, 300mm square x 40mm depth with hole 150mm diameter.	BS	1
105	AASHTO/ASTM Compaction Rammer 2.5kg weight(standard)	AASHTO/ASTM	1
106	AASHTO/ASTM Compaction Rammer 4.5kg weight(modified)	AASHTO/ASTM	6

328



107	AASHTO/ASTM Standard Compaction Mould, with extension collar and base plate.	AASHTO/ASTM	1
108	AASHTO/ASTM Heavy duty modified Compaction mould, with extension collar and base plate.	AASHTO/ASTM	6
109	Hand Operated universal extruder for 35 mm to 152.4 mm dia compaction (proctor), CBR and Marshall with accessories for extruding same samples	AASHTO/ASTM	2
110	Straight edge for cut off excess soil in compacted CBR and compaction mould		4
111	Riffle box 50mm stainless steel slot width, 8 nos of slots and complete with 3 nos of galvanized tray.	AASHTO/ASTM	2
112	Riffle box 12mm stainless steel slot width, 12 nos of slots and complete with 3 nos of galvanized tray.	AASHTO/ASTM	1
113	Wet Washing Sieve Made of Stainless Steel, dimension is 200mm dia. X 200mm(H) with aperture size 75 micron.	BS	3
114	Test Sieves - Made of Stainless Steel, standard diameter of 200mm and chromed steel perforated mesh 75mm,63mm,50mm,37.5mm,28mm, 20mm, 14mm, 10mm, 9.5mm, 6.3mm, 5.0mm,4.75, 3.35mm, 2.36mm, 2.0mm, 1.7mm, 1.18mm,0.6mm,0.475mm,0.3mm,0.15mm,.075mm 0.600mm, 0.425mm, 0.300mm, 0.150mm, 0.075mm(one set consist of 27 nos. sieves) and lid and pan	BS	3
115	Test Sieves - Made of Stainless Steel, standard diameter of 300mm and chromed steel perforated mesh 75mm,63mm,50mm,37.5mm,28mm, 20mm, 14mm, 10mm, 9.5mm, 6.3mm, 5.0mm,4.75, 3.35mm, 2.36mm, 2.0mm, 1.7mm, 1.18mm,0.6mm,0.475mm,0.3mm,0.15mm,.075mm 0.600mm, 0.425mm, 0.300mm, 0.150mm, 0.075mm(one set consist of 27 nos. sieves) and lid and pan	BS	2
116	Test Sieves - Made of Stainless Steel, standard diameter of 450mm and chromed steel perforated mesh 75mm,63mm,50mm,37.5mm,28mm, 20mm, 14mm, 10mm, 9.5mm, 6.3mm, 5.0mm,4.75 mm (one set consist of 12 nos. sieves) and lid and pan	BS	2
117	Test Sieves - Made of Stainless Steel, standard diameter of 300mm and chromed steel perforated mesh 3 in,2 1/2 in,2 in, 1 1/2 in,1 in, 3/4 in ,1/2 in 3/8 in ,1/4 in ,#4, #8 ,#16 ,#30 ,#50 ,#100 ,#200 (one set consist of 16 nos. sieves) and lid and pan	AASHTO/ASTM	1

DS A

118	Casagrande Liquid Limit Device With hard adjustable rubber base fixed with removable brass cup with dropping height according to the standard requirement. A built-in blow counter.	AASHTO/ASTM	2
119	Motorized Casagrande Liquid Limit Device adjustable rubber base fixed with removable brass cup with dropping height according to the standard requirement. A built-in blow counter,	AASHTO/ASTM	1
120	AASHTO Grooving tool for above	AASHTO	3
121	Semi automatic electrical operated cone penetrometer for liquid limit test	AASHTO/ASTM	
122	Glass plate 600 X 400 mm thickness >6mm		2
123	Glass Desiccators with vacuum tap on the cover (300mm dia, vacuum)		1
124	Gas jar 2lt with glass plate and rubber bung	BS	2
125	Soil Hydrometer Glass made with range 0.995 to 1.038g/ml.	AASHTO/ASTM	
126	100mm dia Cohesive Manual Soil Auger 3m long rod (set) & T handle		1
127	76100000 - A2465° - DYNAMIC CONE PENETROMETER (D.C.P.) TRL Specification D.C.P. Complete with wooden carrying case.		1
128	Chloride content kit for sand and fine aggregate	BS	1
129	Specific gravity glass bottle with glass stopper (100,50,25ml) set	BS	2
130	Set organic impurities in fine aggregate	BS	1
131	Electronic pH meter	BS	
	<b>C . Concrete Testing Equipments</b>		
132	Electrically Operated Automatic Machine with digital readout with printer., capacity 2000 kN Concrete Compression Testing Machine travel distance should be more than 315mm with necessary platen for cube and cylinders 100 & 150 mm including standard distance pieces 4 nos.	BS	1
133	portable concrete mixer for trial mix vertical drum	BS	
134	Vibrating table for casting concrete cubes ,300 x 1500mm	BS	
135	Steel cube mould with clamp, base plate and 150mm x150mm side	BS	48
136	Tamping (compacting) bar as BS standard	BS	4
137	Tools (spanners and wrenches) for demolding above		2
138	Curing Tank for test cubes decided at laboratory location (3.5 X 2.0 X 0.6 mm)		1

Q2 A

139	Slump Cone with funnel The set cone with tamping rod and base plate. Manufactured from sheet steel with paint protected. (Slump cone, Metal Tray 600mm x 600mm x 80mm, Tamping rod 16mm dia x 600mm , Steel rule 300mm long)	BS	4
<b>D. Bitumen Testing Equipments</b>			
140	Specific gravity bottle 100ml	BS	2
141	Gooch crucible 44mm dia at the top tapering to 36 mm at bottom with necessary accessories to success the test including glass wool filter flask ,filter tube , Erlenmeyer flask 125ml		4
142	Carbon Disulphide 500ml		3
143	Trichloroethylene 500ml		3
144	Ring and Ball Apparatus (Manual) ASTM D36 but this manual simple apparatus developed as the temperature of bitumen raised, the softness of it increased. The set consists of a beaker, frame, two tapered rings, two balls and centering guides. The apparatus must complete with some accessories to success the test. Supplied All accessories.		2
145	Penetrometer Apparatus consist of dial gauge indicator 25mm x 0.01mm per division, with penetration needle. Test gauge for needle Penetration cups & Transfer dish (set)		1
<b>E. Asphalt Testing Equipments</b>			
146	Automatic Marshall Compactor BS 598, ASTM D1559 Comprises of compactor hammer, hammer guide, mould clamp and laminated hardwood block.	AASHTO/ASTM	1
147	Marshall Mould with collar and base plate.	AASHTO/ASTM	18
148	50kN Computerized Marshall Test Machine with digital display and monitor accessories suitable to fix to the farm so as to work properly Stability mould (breaking head), open type made from steel with inside diameter of 4" to the dimension given in BS 598.	AASHTO/ASTM	1
149	Water Bath 23L Digital Readout Thermostatic Control Stainless Steel Water Bath fitted with stirrer for water circulation, cover, internal stainless steel constructed and outernal fitted with anti-heat protection fiber. Internal dimension (mm) - 350mm x 300mm x 220mm (h) , Controller - Digital, Temperature range (C) - 0 -100 c x 0.1 c, 240v 50Hz 1ph	AASHTO/ASTM	1

150	Centrifugal Asphalt Extraction Apparatus * Working voltage: AC220V 50HZ * Electricity machine: 250W * Governor deflection: 500~3000rotate/min * Specimen weight: 3000g * Stepless timing	AASHTO/ASTM	2
151	Filter papers for above conforms to ASTM ,AASHTO OR BS		150
152	Automatic Asphalt Binder Analyzer) Asphalt ignition oven for bitumen ignition (extraction) of asphalt concrete with all accessories digital balance, sample basket, metal handle ,metal safety cage etc.	EN12697-39	
153	Pavement core drilling machine 5HP 4 - stroke petrol engine This rugged, compact and portable machine with vertical screw feed, is used for pavement core sampling where it is not easy to get electrical power. * Petrol engine 5HP power, 4 stock briggs & Stratton model. * Dimensions 850 x 580 x 1230mm		1
154	Core barrel for above		10
155	Set of jaws to hold the Marshall specimen with flow gauge including necessary bolt extension rod and fittings		1
156	Pycnometer for Maximum Theoretical specific gravity of asphalt concrete 10 lt capacity plastic made 250mm dia, with valve and vacuum gauge supplied with necessary accessories		1
157	Vacuum pumper for above with accessories		1
158	Wire code for extension 10m length including 15A three core flexible wire with 13A, 5A square and round hole each plug base		1
	<b>E. Aggregate Testing Equipments</b>		
159	Motorized Test Sieve Shaker(200mm dis Sieves / 300mm dia Sieves) c/w timer control between 0-60 min, can accept up to 8nos of 200mm diameter sieve or 6nos of 300mm diameter sieve with lid and receiver. Power: 240V 50Hz 1pH	AASHTO/ASTM	1
160	Aggregate Impact Value Test (AIV) Apparatus complete set including standard test accessories for 14mm (sieves, metal cup, Measuring cup, rod etc. as per BS EN 1097-2=1998)	BS	1

*Handwritten signature/initials*

161	Flakiness Index Gauge to dimension specified in BS 812	BS	2
162	Apparatus for 10 percent fines value including standard mould body, detachable base plate, metal plunger, tamping rod and metal measure with all necessary accessories.	BS	1
<b>BORED CAST IN PLACE PILE FOR BRIDGES</b>			
163	Test for support fluid (Bentonite)		
164	Mud balance for density of support fluid		2
165	Marsh cone for Viscosity		2
166	Sand screen test apparatus for sand content		2
167	Electrical pH meter to BS 3145 range pH7 to 14 for pH		1
168	Fan viscometer for shear strength		1

BS A

**APPENDIX - 6**

**SURVEYING EQUIPMENT FOR THE ENGINEER**

Schedule of Surveying Equipment for the Engineer to be supplied by the Contractor.

The Contractor shall supply and maintain in full working order during the progress of the Works, Surveying Equipment and other items, and the supply of expendable surveying material as required from time to time in connection with the Works. All equipment specified shall be new, approved by the Engineer, and for the exclusive use of the Engineer. At end of the Contract the survey equipment and consumable shall be revert to the Employer in good condition.

ITEM	DESCRIPTION	NO.
1	Total Station with GPS and Tripod	02
2	Wild NAK Universal Automatic Level with tripod (or approved equal)	04
3	Sectional leveling staves with leveling bubble, 5m long	04
4	Ranging rods, painted, 2.5m long	10
5	30m steel measuring tape graduated in meters and mm, Rabon Permaline or approval equal	06
6	30m long non-metallic measuring tape graduated in meters and mm, Rabon Permaline or approved similar	06
7	5m steel pocket tape graduated in mm Stanley or approved equal	10
8	Universal straight edge 3m with edge guage	04
9	Aluminum spirit level 1m long with four plumb and two level tubes.	06
10	Safety helmets, reflective jackets and other safety equipments as required	as required
11	Target reflection with 3km range	04
12	Plumbing pole to target and reflector	03
13	Tripod and Tribarch	06
14	Weather proof rubber-cased troches	02
15	Surveying umbrellas, level book etc.	as required
16	Manhole lifting keys for heavy, medium and light duty covers (1 set of each)	02
17	Other miscellaneous equipment, tools and sundries necessary for the carrying out survey work by the Engineer	as required

BWS



**DIVISION 200**  
**EARTHWORK**

Section 201	Clearing and Grubbing	1
Section 202	Building Demolition	6
Section 203	Dismantling Structures	11
Sections 204 - 206	Not Used	
Section 207	Excavation and Embankment	13
Sections 208 - 210	Not Used	
Section 211	Borrow Excavation	38
Section 212	Excavation for Structures	42
Section 213 - 216	Not Used	
Section 217	Special Rock Fill	49
Section 218	Slope and Foundation Protection	51
Section 219	Not Used	
Section 220	Temporary Erosion Control	59
Sections 221 - 227	Not Used	
Section 228	Subgrade Preparation	66
Section 229	Shoulders and Ditches	68
Section 230 - 239	Not Used	
Section 240	Cleaning Culverts, Inlets and Manholes	70

Q5 R

**DIVISION 200  
EARTHWORK**

**SECTION 201  
CLEARING AND GRUBBING**

**201.1 - DESCRIPTION:**

This work shall consist of clearing, grubbing, removing, and disposing of all vegetation and other debris within the construction limits and in other areas within the right-of-way or easement limits, borrow and waste sites as set forth in the Contract and/or as designated by the Engineer. This work shall include selective clearing of areas; site grading of public and private roadways, lanes, vehicular paths or any other existing man made improvements which lie between the construction and right-of-way limits; except such objects as are designated to remain or to be removed in accordance with other sections of these Specifications. This work shall also include preservation from injury or defacement of all vegetation and objects to remain.

Works executed under this Section must also be executed in accordance with conditions stated with regard to environmental matters contained in Division 100 of these Specifications.

**201.2 - MATERIALS:**

Asphaltum based paint for tree surgery.

**CONSTRUCTION METHODS**

**201.3 - GENERAL:**

The Engineer will designate the trees, shrubs, plants and other items to be removed or to remain. The Contractor shall preserve all items that are designated to remain. Alignment stakes, grade stakes, guard stakes, boundary markers, bench marks and tie points shall be preserved until such time as their usefulness has ceased and permission for their destruction is given by the Engineer. All tree removal and/or trimming works shall be executed by skilled workers and in accordance with good tree surgery practices.

**201.4 - CLEARING:**

Areas indicated on the Drawings, and borrow and waste sites defined in the contract or defined by the Engineer, shall be cleared of the obstructions described. In areas where the proposed embankment is to be 1.5 metres or more in depth, measured below the subgrade, all stumps shall be cut off as close to the ground as is practicable but not to exceed 150mm above the ground surface at the base of the stumps. Areas where the proposed embankment is to be less than 1.5 metres shall be treated as prescribed in 201.6.

All merchantable timber and wood in the area to be cleared (except trees designated to remain), which have not been removed from the right-of-way prior to the Contractor taking possession of site for such areas shall become the property of the Employer.

Unsound or unsightly branches of trees and shrubs, which are designated to remain, shall be trimmed as directed. Branches of trees extending over the area occupied by the roadbed shall also be trimmed to give a clear height of six (6) metres above the road and shoulder pavement surface.

## Construction Document

In all areas where stumps and shrubs are to remain, the surface of the ground shall not be unduly disturbed or compacted. Existing ground cover shall be preserved insofar as possible and the area shall be left in a neat and clear condition, reasonably consistent with the surroundings.

All abandoned utility poles within the limits of the right-of-way shall be removed by the Contractor, and either handed over to the utility owner, if so requested, or removed from site.

### **201.5 - SELECTIVE CLEARING AND GRUBBING**

In order that the trees may be properly marked in advance of thinning operations, the Contractor shall give the Engineer at least two weeks notice prior to starting work, or prior to resuming work after suspending operations. Trees or bushes not designated to remain shall be cut. In no event shall selective clearing and thinning operations begin without the Engineer's prior approval. All dead or diseased trees and shrubs, junk, trash, litter, or foreign matter of any kind shall be removed from the areas to be treated. This work shall include uprooting stumps, tops, trunks, branches and dead wood resulting from woodcutting operations or from any other causes.

Trees and shrubs to be preserved shall be carefully pruned to remove all dead wood and diseased or injured tops or branches. In addition, the Engineer may instruct that branches of designated trees be removed to a height of six (6) metres above ground order to improve sight distance, provide head clearance, open vistas, or improve appearance of the tree. Complete clearing may be required in certain areas for the purpose of removing shade hazards, improving sight distances, or improving appearance. Such clearing shall be included under this Section.

The Contractor shall avoid disturbing or compacting the existing ground surface, as well as avoid damage to plant growth. The use of tractors, cranes, winches, or any other heavy equipment, operating anywhere within the area to be selectively thinned, will not be allowed unless exceptions are specifically authorized.

Any injury to trees and shrubs, which are to be preserved, shall be carefully repaired. Disturbed ground surface shall be restored as nearly as possible to natural condition.

Skilled workers according to approved arboricultural practice shall execute all pruning and repair to live trees and shrubs. All pruning scars, cuts and wounds 25 mm in diameter or over shall be painted with an asphaltum base paint. The Engineer may permit such cuts on evergreen trees to remain unpainted. All stumps, new or old, shall be cut to a maximum height of 150 mm above the surrounding ground or as directed by the Engineer. Undesirable trees leaning or falling over the highway right-of-way from outside shall be cut at the property line.

### **201.6 - GRUBBING**

In areas where embankments are to be constructed less than 1.5 metres high, (measured from below the subgrade, complete grubbing of all trees, stumps, roots, bushes or hedge fences shall be accomplished.

In areas where embankments are to be constructed 1.5 metres or higher, measured from below the subgrade, stumps which have not been loosened by clearing and grubbing operations, and non-perishable solid objects, need not be grubbed or removed provided they are cut off so as not to protrude more than 150 mm above the original ground surface. Near the toe of embankment slopes no stump shall extend above a point 300 mm beneath the finished embankment level.

Construction Document

In areas outside of construction limits or selective clearing areas, all stumps shall either be grubbed or cut flush with or below the original ground line. Brush, shrubs, down timber, rotten wood, rubbish and other objectionable objects and vegetation shall be cleared flush with the ground. Such areas will be as directed by the Engineer.

**201.7 - DISPOSAL:**

All wood, trash, debris, stumps, and other foreign matter shall be removed and disposed of by the Contractor. Material may be disposed of at approved waste areas or in accordance with the provisions prescribed.

In urban areas, open burning of construction wastes, demolition wastes, and vegetation will not be permitted. However, if the Engineer determines that no other practical means of disposal exists, open burning of selected vegetation, such as trunks, limbs, etc., approximately 100 mm diameter or less, will be permitted. Vegetation must also be dry and stacked in such a manner as to promote combustion. Incinerators, including air curtain burners, may be used provided the Central Environmental Authority (CEA) approves them. In rural areas, open burning will be permitted under controlled conditions to minimize the amount of smoke. All burning must take place after sunrise and all fires must be extinguished by sunset. It is the intent of this Specification that the health, safety, comfort, and the property of persons in the vicinity are protected from the effects of such burning. All burning shall be executed in accordance with all applicable laws, ordinances, and/ or regulations, and it shall be further subject to the applicable provisions of the Central Environmental Authority.

No burning shall be executed except under carefully controlled conditions. Burning shall be executed under the care of competent watchmen and in such manner that the surrounding vegetation, objects designated to remain within the right-of-way, or adjacent property shall not be damaged. Smoke pollution must be kept to an absolute minimum.

The Contractor will be held responsible for any damage caused by fires. The Contractor shall remove and dispose of burned material; replace trees, shrubs, fences or other objects designated or described to remain, but which have been damaged; and seed burned areas; all in an acceptable manner.

At the option of the Contractor, combustible material may be reduced to chips of a maximum size of 15 mm. The chips may be disposed of in areas where erosion control is required, as a substitute for straw mulch in accordance with the applicable provisions of, or between slope lines and right-of-way lines as determined by the Engineer.

Concrete, stone, brick, and other masonry materials, which have been broken into pieces not exceeding 600 mm in any dimension, may be permitted in embankments but not within 600 mm of the subgrade or 450 mm of the top of the side slopes. Material such as wood, steel, and broken concrete matted together by steel reinforcement will not be permitted in any portion of the embankment. All voids shall be completely filled with suitable material and compacted to the density specified in Section 207.

Upon completion of the work, nothing shall remain within the right-of-way limits, nor along the land adjacent thereto, which was designated for removal in this Specification, which was deposited by the Contractor as the result of any of the operations of construction, which is a nuisance, of any unsightly nature, or in any manner obstructing natural drainage.

The disposal of Construction/Demolition Waste Materials shall be in accordance with Section 207.6.5.

DS A

Construction Document

Borrow and disposal areas shall be arranged by the Contractor, and no specific payment will be made to the Contractor by the Employer in this connection.

All such sites shall be subject to the approval of the local authorities, the Central Environmental Authority, and the Employer.

All costs associated with the provision of borrow and disposal areas shall be deemed to have been spread amongst appropriate other items in the Bills of Quantities as the Contractor shall have deemed appropriate.

The Contractor will be required to arrange for disposal sites for all waste material resulting from clearing and grubbing, and obtain local government and Central Environmental Authority approval of the site and disposal methods.]

The Contractor will be required to arrange for disposal sites for all waste material resulting from demolition, and obtain local government and Central Environmental Authority approval of the site and disposal methods.]

Bidders attention is drawn to the upper typical cross section on Drawing No TX0008. The typical cross section illustrates that various segments of cutting for subsequent road development construction stages (consisting of future road widening) may be utilized for the production of additional material where there is a shortfall of material for the construction of embankment fill. Limits are indicated in the Plan and Profile drawings. The approval of the Engineer shall be obtained for such widening of cuttings where widening is not indicated in the drawings as a requirement of the Works, and such approval will not be unreasonably withheld.]

Future interchange sites may be used for the temporary stockpiling by the Contractor of material for use in the Works, with the approval of the Engineer. It should be noted by bidders that the 'future interchange' denoted at approximately Km 27+900 has been withdrawn as a 'future interchange' and, accordingly, the land which was to have been reserved for that interchange will not be available for such temporary stockpiling.

Permanent disposal of material within the Right-of-Way will generally not be allowed. Any dispensation in this respect will be subject to the approval of the Engineer in the specific circumstances of such disposal.]

It will be the Contractor's responsibility to provide borrow and disposal areas for the Works, as necessary, in accordance with the prevailing statutory regulations, and all in conformity with his materials utilization and disposal scheduling. No specific payment will be made for haulage of materials from borrow pits and to disposal sites, and all such costs shall be deemed by the Employer to have been spread amongst other items in the Bills of Quantities as the Contractor shall have deemed appropriate.]

**201.8 - METHOD OF MEASUREMENT:**

The unit measurement for General Clearing and Clearing and Grubbing shall be Hectares.

Clearing and Grubbing for waste sites or borrow pits furnished by the Contractor shall not be measured separately.

General Clearance works shall include the demolition and removal of all articles, objects, obstructions and debris which are expressly required to be cleared, except for those separate items set out in this Clause.



Clearing and Grubbing works include for general clearance works plus grubbing of tree stumps, for trees with diameter less than 300mm, removal of hedges, fences and walls including the removal of below ground hedge stumps, fence post and wall foundations required to be removed.

Areas of General Clearing and Clearing and Grubbing works shall be as directed by the Engineer.

Diameters of trees shall be measured 1.0m above ground level. Items for removal of trees with diameters 300mm and over shall be measured separately, and shall be deemed to include the removal of the stumps, backfilling stump voids and disposal of tree remains.

**201.9 - BASIS OF PAYMENT:**

The approved quantities, determined as provided above, shall be paid for at the contract price bid for the pay item listed below, which price and payment shall be full compensation for executing all the work prescribed in a workmanlike and acceptable manner, including all labour, materials, tools, equipment, supplies, and incidentals necessary to complete the work. The unit bid price will be full compensation for the measured quantities performed, and accepted in accordance with these Specifications.

All salvable material, including merchantable timber referred to in 201.4, shall become the property of the Employer unless otherwise indicated in the Drawings or in these Specifications, and any salvage value expected shall be computed as a credit before arriving at the bid price for this pay item.

**201.10 - PAY ITEM:**

ITEM	DESCRIPTION	UNIT
201.001	General clearing	Hectare
201.002	Clearing and grubbing	Hectare
201.003	Remove of trees diameter 300mm to 900mm	Number
201.003	Remove of trees diameter 900mm to 1200mm	Number
201.003	Remove of trees diameter 1200mm	Number





**SECTION 202  
BUILDING DEMOLITION**

**202.1 - DESCRIPTION:**

This work shall consist of the complete demolition (unless indicated otherwise on the Drawings and/or as instructed by the Engineer) of all buildings and appurtenances remaining within the Contract right of way limits (wholly or in part) at the date the Contractor takes "possession of the site", (either wholly or in part) as is appropriate. Demolition shall include for not only the parts of the building above ground level, but also all substructure elements, all as referred to in Clause 202.3 below.

It shall also include rodent control when specified in the Contract, and disconnecting utilities, salvaging and or disposing of the resulting materials in the manner and subject to the conditions and regulations prescribed.

**202.2 - MATERIALS:**

The rodenticide treated bait shall consist of the following:

**Type 1 Bait** - An anticoagulant, 0.5 percent concentrate, such as warfarin, pival, fumarin, PMP, etc., mixed with cereals and other rodent attractants in the following proportions by weight:

One part anticoagulant to seven parts coarse yellow corn meal; five parts rolled oats; one part granulated sugar; one part corn oil.

In the event rodents do not accept this formula chopped fruit may be substituted for the rolled oats in the same proportion.

**Type 2 Bait** - Zinc phosphide, 100 percent concentrate (94 percent minimum assay), mixed in the proportion of 1:96 of ground meat or canned dog food.

All rodenticides shall be handled and mixed in the bait in accordance with the manufacturers' instructions.

**Insecticide** - Two percent Diazinon Dust, or five percent Malathion Dust, or 10 percent Carbaryl Dust, or two to five percent Chlordane Dust.

**CONSTRUCTION METHODS**

**202.3 - UTILITIES:**

The Contractor shall be solely responsible, for making all necessary arrangements for/and performing any necessary work to the satisfaction of the Utility Authorities and Local Governments involved, with regard to the discontinuance or interruption of all public utilities or services, such as water, sewage, electricity, and telephone, which may be affected by designated demolition works to be performed as part of the Contract.

*BA*

**202.4 - DEMOLITION AND EXTENT OF REMOVAL:**

Buildings and appurtenances shall be removed to the existing ground level, which operation shall include removal of concrete slabs or any other type of floor resting upon the ground. Basements shall be cleared of all debris, appliances, wood or metal partition walls, wood floors, etc., so that only the foundation walls and basement floor remain. The basement floors shall be shattered. If pits, trenches, holes, or basements are not to be eliminated in subsequent excavation operation, they shall be backfilled. All backfill within the roadway prism shall be accomplished in accordance with the requirements of Section 207. Compaction of backfill outside the roadway prism shall be performed to obtain a density equal to that of the surrounding ground.

**202.5 - DISPOSAL OF MATERIALS:**

The Contractor at an approved disposal site shall dispose of materials resulting from demolition. Concrete, stone, brick or masonry broken down in accordance with 201.7 may be placed in the embankments, if permitted by the Engineer.

The Contractor will be required to arrange for disposal sites for all waste material resulting from demolition, and obtain local government and Central Environmental Authority approval of the site and disposal methods.

**202.6 - RAT CONTROL:**

When specified in the Contract, the following rat control provisions shall apply.

**202.6.1 - General:**

The Contractor shall furnish and place suitably prepared bait containing rodenticide in and around buildings to be demolished and also furnish and place insecticide for control of ectoparasites. Two rodenticide treated baits differing in content and method of placement will be required within 24 hours after receipt of notification to proceed. The Contractor shall place rodenticide treated bait within the building demolition area.

If the Contractor does not promptly furnish the rodent control measures, the Engineer may provide the measures as required and deduct the cost from the money due the Contractor.

**202.6.2 - Rodent Control Operations:**

Type I bait containing anticoagulant shall be placed in shallow bait containers fastened to the floor surface of buildings or in shallow containers heavy enough to prevent overturning or removal to burrows. The containers shall be protected from domestic animals and weather and shall be distinctly labelled with the word Poison and symbol thereof. The initial rate of application shall not be less than 2 kg per 100 square metres of building area.

Type II bait containing zinc phosphide shall be wrapped in paper squares approximately 100 by 100 mm in size to form baits about the size of a candy "Kiss". Bait should be placed out of reach of children or pets and should be tossed in otherwise inaccessible places. Initial rate of application shall be a minimum of 20 baits per residential building and 40 baits per commercial building.



## Construction Document

Bait shall be placed near burrows, runways, or other areas showing rodent signs. A shallow pan containing water shall be placed in each building. At the time the bait is set out, the Contractor shall treat all runways; burrow entrances; nests and vertical surfaces against which the rodents may brush with the insecticide dust at a rate of 1 kg per residential building and 2 kg per commercial building.

Location of all bait, bait containers and water containers shall be noted and bi-weekly inspection and replacement of bait and water shall be made. In the event bait is not touched for several days, the bait shall be moved to other areas in the building. Mouldy, wet, caked or insect infested bait shall be replaced. Insecticide dusting shall be repeated once per month. Baiting and insecticide dusting shall continue until all buildings and rubble are removed from the building demolition area.

A sign shall be posted at the front and rear of each building treated for rodent control. The sign shall be a minimum size of 750 by 750 mm with red lettering and poison symbols on a contrasting background. Wording of the sign, in the three languages of common usage in Sri Lanka, shall be as follows:

**THIS BUILDING  
TREATED  
FOR RODENT CONTROL  
POISON  
NO ADMITTANCE**

Minimum size lettering of the word POISON and symbols thereof shall be 150mm. All other lettering shall be a minimum of 100mm. The sign shall be made of weather resistant materials such as plastic or exterior plywood and shall be securely fastened to the building.

Where buildings to be demolished have had exterior poison warning signs placed upon them during a previous, recent phase of the rodent control program, the signs remaining on the buildings to be demolished will serve as adequate warning and the signing requirement of this Section is waived.

Exterior poison warning signs previously placed by the Client or the Government shall, upon demolition of the buildings, remain Client's or Government property and shall be stored on the project for removal by the Government.

Dead rodents shall be removed from the building demolition area daily and shall be buried at a minimum depth of 600 mm. The disposal area shall be provided by the Contractor and shall be subject to approval by the Engineer.

### **202.7 - WATER WELLS:**

Water wells serving buildings that have been or to be demolished shall be abandoned as follows:

Water Wells that are abandoned shall be capped by removing the pump and piping and filling the upper 3 metres of casing (flush with the end of the casing) with concrete to prevent aquifer contamination.

The Contractor shall obtain a permit to abandon a water well from the Regional Health Officer and follow all procedures prescribed in the permit.

**202.8 - SEPTIC TANKS:**

A septic tank that serves a building that has been, or is to be, demolished shall be abandoned as follows:

The local government authority shall remove the contents of the septic tank and the tank removed and disposed of at an approved landfill. The excavation made to remove the tank shall be backfilled with material free of sod, trash, organic substances and muck. The backfill shall be compacted as outlined in 202.4.

**202.9 - METHOD OF MEASUREMENT:**

The unit of measurement will be the number of each building (per area range) to be demolished, each water well (per depth range) to be sealed and/or backfilled or each septic tank to be removed and hole backfilled.

The area used in the classification of building areas and other structures shall be their approximate area at ground level only, no allowances have or will be made for any upper floors or basements. Well depths shall be in five (5) metre depth ranges from ground level to bottom of well.

Pipelines within buildings and other structures shall be measured only where their nominal internal diameters exceed 300mm, otherwise they shall be deemed to be included in demolition works.

**202.10 - BASIS OF PAYMENT:**

The buildings, and appurtenances, demolished and removed as provided above will be paid for at the Contract pay item unit price per building, which price and payment shall constitute full compensation for performing all of the requirements of this item, including any utility works, furnishing all material, labour, tools, equipment, supplies, and incidentals thereto. Removal shall include for either including such into the works, or disposal off site. Salvageable materials resulting from the demolition shall become the property of the Contractor, unless otherwise indicated in these specifications, on the Drawings or elsewhere in the Contract Documents. Any salvage value of disposed of materials is to be considered as already credited by the Contractor to the Employer in the applicable demolition and/or abandonment pay item unit rates or prices.

Further to the above paragraph, the Contractor's attention is drawn to the fact that owners/occupiers of properties to be demolished to make way for this Project, are legally entitled to remove themselves any salvageable materials, within a six (6) month period after receiving compensation to vacate their properties. It will be the Contractor's responsibility to ascertain the value, if any, of possible remaining salvageable materials. No claim for loss of salvageable material credit will be accepted from the Contractor.

The cost of furnishing, placing and maintaining rodenticide treated bait and water, the cost of furnishing and placing insecticide, the cost of signing and disposal of dead rodents, including all material, labour and equipment shall be included in the unit price bid for "Building Demolition".

The water wells or septic tanks abandoned as provided above will be paid for at the contract price per water well or septic tank which price and payment shall constitute full compensation for performing all of the requirements of this item, including furnishing all material, labour, tools, equipment, supplies, and incidentals thereto.



202.11 - PAY ITEMS:

ITEM	DESCRIPTION	UNIT
202.001	Demolish building area not exceeding 50sq.m	Number
202.002	Demolish building area 50 – 100sq.m	Number
202.003	Demolish building area 100 – 150sq.m	Number
202.004	Demolish building area 150 – 200sq.m	Number
202.005	Demolish building area 200 – 250sq.m	Number
202.008	Demolish building area 250 – 300sq.m	Number
202.007	Demolish building area 300 – 400sq.m	Number
202.008	Demolish building area 400 – 500sq.m	Number
202.009	Demolish building area 500 – 750sq.m	Number
202.010	Abandon water well depth up to 3.0m	Number
202.011	depth exceeding 3.0 – but not exceeding 6.0m	Number
202.012	depth exceeding 6.0 - not exceeding 10.0m	Number
	depth exceeding 10.0 - not exceeding 15.m	Number
	depth exceeding 15m	Number
202.013	Abandon septic tank	Number
202.014	Utility posts	Number
202.015	Culverts	Number



**SECTION 203  
DISMANTLING STRUCTURES**

**203.1 - DESCRIPTION:**

This work shall consist of dismantling such structure or structures specifically designated on the Drawings for careful removal, match marking, handling and storage or disposal as required.

The Contractor is responsible for determining the current condition of the structure(s) and shall use methods and procedures for dismantling structures in a safe and efficient manner.

For Bridges the work shall also include the preparation of a demolition/dismantling method statement by the Contractor. The statement shall be prepared and sealed by a Professional Engineer registered in Sri Lanka, experienced in structural analysis of bridges.

The Method Statement shall include a complete structural analysis for all phases of the demolition/dismantling with due regard to the existing condition of the structure at the time the work is performed. Additionally, the analysis shall show that the structure meets the design criteria of the latest edition, including all Interims, of the *British Standard Institution Code of Practice for Bridge Design, BS 5400:1990* and the *Road Development Authority of Sri Lanka Bridge Design Manual, 1997* during all phases of demolition/dismantling. The design loads shall match those applied to the structure by the Contractor's "means and methods" of demolition/dismantling.

The demolition/dismantling schedule shall be provided to the Engineer at least seven calendar days prior to the programmed commencement of any demolition/dismantling work. Receipt of the demolition/dismantling Method Statement does not constitute review or approval or relieve the Contractor of his/her responsibility to satisfactorily demolish/dismantle the structure specified.

Drainage culverts to be demolished are indicated in the Plan and Profile drawings. All buildings and structures within the boundaries of the Right-of-Way shall be demolished subject to the prior confirmation of the Engineer.

None of the structures dismantled, will be re-erected.

**203.2 - MATERIALS:**

Not applicable

**203.3 - CONSTRUCTION METHODS:**

The work shall include dismantling, storing, and/or disposing of designated structures shown on the Drawings and/or instructed by the Engineer.

If the old structure is to be re-erected or parts are to be reused it shall be carefully dismantled (without unnecessary damage), the parts match-marked, and carefully stored and re-erected as shown on the Drawings and/or instructed by the Engineer. Grubbing of foundations or stumps and disposal, if required, shall be accomplished in accordance with the provisions of 201.





**203.4 - METHOD OF MEASUREMENT:**

"Dismantling Structures" will be measured as a complete unit and shall include the complete execution of the work of dismantling, handling, storing, re erecting and/ or removing all of the structures so designated.

**203.5 - BASIS OF PAYMENT:**

The quantity, determined as provided above, will be paid for at the Contract unit price bid for this item, which price and payment shall be full compensation for completing the item, including re-erection and/ or removal and disposal of all falsework, debris and refuse resulting from the work, clearing the area on completion. The cost of preparation and transmittal of the demolition/dismantling Method Statement shall be included in the unit price bid for item 203.001

**203.6 - PAY ITEM:**

ITEM	DESCRIPTION	UNIT
203.001	Masonry	Cubic metres
203.002	Concrete	Cubic metres
203.003	Rubble masonry	Cubic metres

*Q/A*

**SECTION 207  
EXCAVATION AND EMBANKMENT**

**207.1 - DESCRIPTION:**

This work shall consist of excavation for the roadway, constructing embankments, including slope preparation, benching, hauling from excavation for the roadway, placement and construction of all unclassified material, of whatever character encountered, from within the limits of the work and borrow areas not being measured or paid for elsewhere in the Contract Documents. Material excavated and hauled from borrow areas shall be measured separately as described in Section 208.

Material placed against the existing embankment shall be the same type as that used in the existing embankment in order to avoid differential settlements.

The excavations for preparing areas upon which embankments are to be placed, preparing the subgrade including shoulder areas, slopes, ditches and drains; constructing benches and removing slides disposing of unsuitable and surplus material; as may be required by the Drawings or as directed by the Engineer; all in accordance with these Specifications and in reasonably close conformity with the lines, grades, thicknesses, depths and cross sections shown on the Drawings and/or directed by the Engineer.

The Embankment construction shall include preparation of the areas upon which embankments are to be placed, construction of dykes, placing and compacting approved material, filling holes, pits, and other depressions within the roadway area. The compaction of embankments and sub grades will be in accordance with these Specifications.

Broken concrete, broken asphalt or other solid materials shall not be placed within embankment areas or supporting the roadway shoulders and pavement structures unless the prior written approval of the Engineer.

**207.2 - MATERIALS:**

Materials shall meet the requirements specified in 715.11 and Section 716 and Table 207.1.

**207.2.1 - Quality Control Testing:**

The Contractor shall submit a quality control method statement detailing the methods, including sampling and testing, by which the quality control programme will be conducted. The statement, prepared in accordance with the guidelines set forth in AASHTO, T180, shall be submitted to the Engineer at the pre-construction conference. The work shall not begin until the Method Statement is reviewed for conformance with the Contract Documents.

The Contractor's personnel shall include at least one qualified technician who shall be responsible for all field sampling and testing necessary to determine the magnitude of the various properties of the embankment and the subgrade governed by the Specifications and shall maintain these properties within the limits of this Specification.

Pursuant to AASHTO T238-86, the Contractor shall notify the Engineer prior to construction of the test strip, and shall record the data for all compaction testing on the forms as set forth including maintaining records of the equipment used to compact the material. Completed test data forms shall be provided to the Engineer at or immediately after the time of testing.

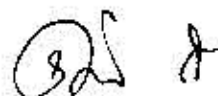

## CONSTRUCTION METHODS

### 207.3 - EXCAVATION:

Excavated materials are to be classified as below:

#### i) Top Soil

Topsoil is defined as the top layer in-situ material containing vegetation, roots and seeds. Such material to be excavated shall be carefully removed, stockpiled on site

#### ii) Unclassified Material.

Unclassified Material is as defined in 716.1.1 of these Specifications. Such material excludes materials defined as topsoil, rock or unsuitable material.

#### iii) Rock

Rock is as defined in 716.1.2 of these Specifications.

Stones or boulders with a volume larger than 0.5 cubic metres, shall also be measured as rock.

The priority of the use of excavated rock on this project will be for aggregates for concrete and/or asphalt works, the provision of fine aggregates for use instead of river or sea sand and/or gravel, base courses, rock fill, stone pitching, gabion fill and other related soil erosion and slope protection works.

Due to statutory restriction on the mining of river and sea sand in the environs of the Works it is envisaged that all fine aggregate will be produced by the crushing of excavated rock.

#### iv) Unsuitable Material

Unsuitable material will generally comprise, highly organic clays and silts, peat soils containing large amounts of roots, grass and other vegetable matter. Materials that are soft or unsuitable merely because they are too wet or dry are not to be classified as unsuitable unless otherwise directed by the Engineer. Unsuitable materials are typically soft clays, organic clays or silts and peats which, left in place, will cause instability of embankment side slopes or unacceptable post construction settlements.

The actual limits and depths to which unsuitable material shall be excavated shall be verified during construction by excavating test pits as required or where directed by the Engineer.

Unsuitable Material shall include material encountered in cut areas and in the foundation of the embankment that is unsuitable for incorporated into the works pursuant to these specifications, and shall be excavated and disposed of as directed by the Engineer.

Unsuitable material may be stabilized, by being mixed with lime or cement, such material shall then be defined as stabilized material.

Stabilized material may then meet the criteria for unclassified material and be incorporated into the works, subject to the prior written approval of the Engineer.

The provision of suitable sites for the permanent deposition of material to be disposed of shall be the responsibility of the Contractor. No specific payment shall be made to the Contractor in respect of the provision of such sites, and he shall comply in all respects with the requirements of the local government authorities and the Central Environmental Authority.]

**207.3.1 - Slopes:**

Slope lines shall conform to the lines and grades shown on the Drawings and/or established by the Engineer within the following tolerances: For all slopes back of the ditch line a construction tolerance of plus or minus 300 mm, measured in a horizontal plane, will be permitted. No change will be permitted in the width, grade or dimensions of the roadway ditch due to the tolerance. The slope may be varied only by permission of the Engineer. Slopes shall be trimmed neatly to present a uniform surface, free from hollows or protrusions and loose or overhanging rocks. Slopes shall not be undercut. The tops of all slopes, except where the material is of solid rock, shall be rounded as shown on the Drawings.

The Contractor shall take precautions by benching or other methods, and/or as directed by the Engineer, to prevent slides and slip outs.

In all roadway cuts, including areas where ledges of rock or hard shale, boulders, or other solid formations are encountered at or near subgrade elevation, the excavation shall be carried to a minimum depth of 150mm below the surface of the subgrade for the full cross section width of the roadway between the ditches.

The surface of all areas excavated below subgrade elevation shall be graded in such a manner that un-drained pockets are eliminated before placing subgrade material.

Excavation to the 150 mm limit will be paid for at the contract unit price bid for "Rock Excavation" or "Unclassified Excavation" as determined by the Engineer. Excavation made below this 150 mm limit will not be paid for.

**207.3.2 - Use of Explosives:**

The use of any explosives for the excavation of rock, if permitted, will be as last resort only. Blasting will only be considered if the Contractor provides a method statement substantiating that such proposed work methods are fully compliant with latest Laws and Regulations pertaining to the acquisition, storage and usage of explosives, prescribed under the Sri Lanka Law: Explosives Act No 21 (and its latest amendments) and or any other pertinent legislation.

The Contractor shall not employ any method of blasting which will result in breakage beyond the slope line, or which is dangerous to the public, destructive to property, would cause unacceptable noise, dust or other environmental impacts to the site and other third parties. Excessive blasting or "over-shooting" will not be tolerated. Any area of material outside the authorized cross section, which becomes shattered or loosened by blasting shall be removed and replaced if so ordered by the Engineer, without compensation to the Contractor.

The general environs of the proposed construction work is one of the most densely populated rural areas of Sri Lanka. The intention of the "last resort" wording in sub-Section 207.3.2 of the Specifications is that blasting should only be used as the means of excavating in rock material when no other less socially disruptive methodology could be employed. It is fully expected that the Contractor will utilize blasting in locations of solid rock. Provided that the Engineer is satisfied that the rock material in any particular location cannot reasonably be ripped, permission for the

use of blasting will not be unreasonably withheld. The Contractor shall be responsible for compliance with all regulations with regard to blasting within the area of the Site.

Chemical blasting shall be used where blast vibrations resulting from the use of explosives at adjacent properties and other locations are not acceptable, all as directed by the Engineer.

### **207.3.3 - ROCK EXCAVATION:**

#### **207.3.3.1 - Rock**

Rock is as defined in Clause 716.1.2 of these specifications.

#### **207.3.3.2 – Pre-splitting Technique:**

When explosives are used in excavation, the pre-split technique shall be used except for fill bench construction and where slopes flatter than 1 to 1 are designed. This involves a single row of holes drilled along the neat excavation line and the blasting charge fired before any adjoining main excavation area is blasted. Depending on the type of rock, the drill holes for the presplitting shall be on centres from 0.6 to 1.5 metres as determined by field demonstration.

The holes to be loaded for pre-splitting shall be string loaded as recommended by the manufacturer of the explosives. The pre-splitting may be accomplished during the primary blast by delaying the primary holes so the pre-splitting holes will fire ahead of them. The end result is intended to yield a minimum of breakage outside the neat line of the Drawing cross sections. The Contractor shall make available upon request a record of the spacing and the amount and type of explosives used in the pre-split operation.

#### **207.3.4 - Archaeological and Historical Findings:**

Should the Contractor's excavation operations encounter remains of prehistoric people's dwelling sites or artefacts of historical or archaeological significance, the operation in that locality shall be temporarily discontinued. The Engineer will contact appropriate authorities to determine the disposition thereof. When directed by the Engineer, the Contractor shall excavate the site in such manner as to preserve the artefacts encountered and shall remove them for delivery to the custody of the proper State authorities. Such excavation, if any, will be considered as additional work pursuant to Clauses 4,8,12 and 13 of the Conditions of Contract.

#### **207.4 - BENCHES:**

Benches to be constructed either above or below the profile grade shall conform to the dimensions shown on the Drawings and/or as directed by the Engineer. Necessary drainage shall be placed as directed before backfilling. The Contractor shall arrange benching operations to allow sufficient time for the Engineer to complete all cross sections before placing embankment material.

#### **207.5 - DITCHES:**

Ditches, drains, channels, and stream changes, including inlet and outlet ditches for culverts, shall be constructed where shown on the Drawings and/or as directed by the Engineer. Diversion ditches, where specified, shall be cut beyond the rounded edges of slopes. Ditch slopes shall be rounded and trimmed neatly to line, and flow lines shall be trimmed of irregularities in the grade, which might cause surface water pockets.



## 207.6 - DISPOSAL OF MATERIAL:

### 207.6.1 - Suitable Material:

All suitable material excavated as above provided shall be used for forming embankments for the roadways, connecting roads, ramps and approaches; for constructing subgrade and shoulders; around structures and buildings; or for any other purpose necessary for the completion of the project as shown on the Drawings or directed by the Engineer.

Unclassified material, hard shale and rock, as defined in 716, are suitable for use in embankments. Within soil groups, preference shall be given to the more granular soils, which have greater dry weights, greater percentages of coarse and fine aggregate, and lower liquid limits.

Where the quantity of suitable material required for certain work is limited, such material shall be excavated, stock piled, and protected from contamination, erosion etc. reserved for the purpose as directed by the Engineer. Should the Contractor fail to reserve such available material when so directed, the Contractor at no additional cost shall make replacement to the Client.

### 207.6.2 - Unsuitable Material:

The Engineer may designate materials, which cannot be satisfactorily placed and compacted to a stable and durable condition, as unsuitable. Sod, trash, organic substances, and muck are considered unfit for use in embankments.

Soil to be excavated, or being excavated, that contains excessive moisture shall also be considered unsuitable for use in embankments. However, the Contractor may at their option dry the material and use it in the construction of embankments. Aeration, or other drying method, shall be at the expense of the Contractor.

If the Contractor elects to waste rather than dry, suitable replacement material shall be furnished and placed by the Contractor at his expense, if needed to complete embankments or otherwise fulfil the intent of the Drawings. Any material borrowed to obtain necessary replacement material shall be accomplished in accordance with the provisions of Section 211.

Certain unsuitable material may, be set aside to be stabilized, and re-used in the works.

### 207.6.3 - Waste:

The Contractor shall locate and furnish all sites for disposal of waste and surplus material, except for those sites shown on the Drawings. When directed by the Engineer, surplus material shall be used in uniform flattening of embankment slopes or widening of shoulders within the right-of-way limits.

Steepening of slopes will not be permitted.

The Contractor shall submit to the Engineer, for his review and approval, a detailed method statement for waste disposal works, proposed for sites either indicated on the Drawings or others proposed by the Contractor himself.

The method statement should indicate the location, limits and details of the proposed waste sites, disposal methods, and his proposals for waste disposal indicating their concurrence with all Solid Waste Management Regulations set down by The Central Environment Authority (CEA), any



other concerned Authority and/or as may be required elsewhere in the Bid Documents. No approval by the Engineer will be granted unless the Contractor's submission also includes copies of permits, written acceptance or no objection to Contractor's proposals by from all concerned parties.

The Method Statement shall be submitted to the Engineer for approval, no waste disposal work is to be commenced until the Engineer gives written approval.

Upon completion of work, all waste sites shall be neatly trimmed and drained and all debris and spoil disposed of in accordance with the approved Drawing. No material shall be wasted at places other than those approved, except as provided, nor shall any material be wasted above established grades of any road unless authorized by the Engineer in writing. Waste areas shall be graded, fertilized, seeded and mulched by the Contractor in accordance with Section 652 of these Specifications.

For small quantities, not to exceed 300 cu m, of waste outside the right-of-way limits, the Contractor need not prepare a separate method statement, but to execute works in full compliance with approved method statements for larger disposal sites. For such small quantities of waste outside the right-of-way limits, the Contractor shall comply with existing laws, obtain permits, approvals or no objection certificates from concerned Authorities and save the Client harmless from any claims for damages, which may result from the waste. In addition, the Contractor shall also comply with the provisions stated above with regard to trimming, draining, fertilizing, seeding and mulching.

The Contractor shall conduct all waste disposal operations with absolute minimum, if any, pollution or sedimentation of rivers, streams, lakes, ponds, or other bodies of water.

Construction/Demolition Waste Material as defined in 207.6.5 will not be permitted in a site provided by the Contractor for disposal of surplus material except as follows:

Portland Cement concrete and hot-mix asphalt removed from a project may be disposed of in a waste site provided the following requirements are met:

- 1) Placement shall be in accordance with 207.7.3.2.3 - Rock.
- 2) All Portland Cement concrete and hot-mix asphalt in the waste site shall be covered with 600 mm of soil.
- 3) The Drawing approved by the Engineer for the waste site shall show the location of any Portland cement concrete and hot-mix asphalt to be wasted and/or the original Drawing supplemented as required.
- 4) The area of disposal for hot-mix asphalt shall be limited to 0.8 Ha and may be located within a waste site covering more than 0.8 Ha.
- 5) Portland Cement concrete or other masonry type products will not count against the 0.8 Ha maximum size if all the reinforcing steel and/or wire mesh have been removed or cut off flush at the outer edges.
- 6) The area of disposal of Portland Cement concrete and hot-mix asphalt shall be completed and covered within 180 days.

- 7) The disposal area of Portland Cement concrete and hot-mix asphalt shall not be within 90m of a wetland, within a perennial stream, or within a 100-year floodplain.
- 8) The requirements as set forth in 207.6.5 Construction/Demolition Waste Material are to be followed.

**207.6.4 - Conduit or Pipelines:**

Any Conduit or Pipeline designated to be re-laid shall be removed with care and stored where it can be protected from damage until reused. The Contractor shall replace sections lost from storage, damaged by negligence, or used in an improper manner.

**207.6.5 - Construction/Demolition Waste Material:**

Disposal of Construction/Demolition waste material outside of the Client's right-of-way is controlled by the Solid Waste Management Regulations of the Central Environmental Authority (CEA) and is defined as follows: "... means waste building materials, packing, and grubbing waste, resulting from construction, remodelling, repair and demolition operations on houses, commercial and industrial buildings, pavements, including, but not limited to, wood, plaster, metals, asphaltic substances, bricks, blocks and concrete, other masonry materials, but does not include asbestos waste." Hazardous Waste will be disposed of in an approved area for that particular material.

Construction/Demolition waste material cannot be disposed of outside of the Client's right-of-way unless it is taken to an approved commercial landfill or a permit is obtained by the landowner or Contractor in accordance with the above cited statute and regulations.

Construction/Demolition waste material consisting of concrete, asphalt, crushed stone, bricks and blocks may be disposed of within the Client's right-of-way with approval of the Engineer. The waste material shall be covered with a minimum of 600 mm of soil, drained, and seeded.

The landowner or Contractor must apply for and receive approval for all Construction/Demolition waste areas outside of the Client's right-of-way from the CEA prior to use. The disposal of trees, stumps, woodchips, and yard waste generated from land clearing when generation and disposal occur on the same property is exempt from the requirements of CEA approval. A landowner using Construction/Demolition waste material to improve the grade of the land and if the area of that land does not exceed 0.2 Ha is exempt from the requirements of CEA approval provided that the landowner or contractor does not fill wetlands, adheres to best management practices for construction and maintains cover over the material. The Construction/Demolition waste material exemption for landowners does not apply to multiple 0.2 Ha sites on the same parcel of land.

The Contractor shall not create any temporary disposal sites on the right-of-way but must dispose of all Construction/Demolition waste in accordance with this section.

**207.7 - FORMING AND COMPACTING EMBANKMENT:**

Slope lines for all embankments shall conform to the lines shown on the Drawings or established by the Engineer, except that a construction tolerance of plus or minus 300mm, measured in a horizontal plane, will be permitted, except further that the roadbed width due to the tolerance shall not be less than Drawing width. The slopes may be varied only by permission of the Engineer. Slopes shall be trimmed to present a neat and uniform surface, free from hollows or protrusions. The tops of all slopes shall be rounded as shown on the Drawings.

Handwritten signature or initials, possibly "B.A.", in black ink.

**207.7.1 - Preparation:**

When fills are 1.5 metres or less in depth, the top soil and sod shall be stripped to the depth specified by the Engineer, and the top 200 mm of the embankment foundation shall be scarified and compacted to the density requirements specified.

If the required density is unobtainable due to excessive moisture, organic substances, or other causes, the Contractor may be required, as directed by the Engineer, to remove and waste the in-place material to a depth prescribed by the Engineer before starting embankment. Alternatively to place an initial layer of rock, hard shale, or granular material, thickness to be prescribed by the Engineer, or both, including if requested a layer(s) of geotextile material.

When embankments of less than 1 metre in depth are to be placed upon old concrete pavements or pavements with concrete base, the pavements or base shall be removed and disposed of unless otherwise directed by the Engineer. When embankments of 1 metre or more in depth are to be placed on old concrete pavements, the pavements shall be broken up in pieces not to exceed 90,000 square mm and may be left under the new embankments, unless otherwise directed by the Engineer. When embankments are to be placed upon other than rigid types of pavement, the pavements, shall first be scarified to their full depth and re-compacted.

All existing slopes, other than rock, against which embankments are to be placed shall be ploughed or deeply scarified to allow blending of the in-place material with the embankment material. When specified in the Contract or directed by the Engineer, the slopes shall be benched before the embankment is placed.

Prior to the commencement of excavation and embankment, when called for in the Contract, topsoil shall be removed, stockpiled and protected against contamination and/or erosion, at the locations designated by the Engineer. Construction and payment procedures shall be in accordance with Section 651.

**207.7.2 - Materials for Formation and Compaction of Embankments:**

Embankment materials, test methods and the Contractor's quality control requirements shall conform to be applicable provisions of Section 716.

**207.7.3 - Placing Embankment:**

**207.7.3.1 - General:**

No embankment shall be placed on soft, unstable material.

During the process of excavation and embankment construction, the roadway shall be maintained in such a condition that it will be well drained at all times. Depositing and compacting embankment in layers shall be started at the lowest point of the fill below grade, at the bottom of ravines, and at the foot of slopes on side hills. Unconsolidated soil or unclassified material, unless removed under other provisions of the Specifications, shall be removed as directed by the Engineer, replaced and compacted as specified before placing embankment thereon. The layers shall be constructed approximately parallel with finished grade. Each layer, before starting the next, shall be levelled and smoothed by means of power driven graders, dozers or other suitable equipment with adequate weight, capacity and power to do the work. Layers shall be extended across the entire fill at the level of deposition unless otherwise authorized by the Engineer. Each layer, before starting the next, shall be compacted.

Materials to be used in any area of an embankment shall be free from stumps and spongy or organic soil. The amount of organic material shall be no greater than that specified in the applicable provisions of Section 716.

Soil having organic material greater than that specified in Section 716 shall be disposed of as directed in 207.6.3. Embankments at bridge abutments shall be free of rock in the area where piles are to be driven, unless otherwise specified.

Where rock is required for the entire embankment at bridge abutments, the piles will require pre-drilling. Pre-drilling may be required for other embankments where the depth, density of material, or negative skin friction requires it. When embankment is being formed around structures, the material shall be deposited on both sides of the structure in approximately level layers and in accordance with 212.10.

The Drawing and sequence of operations shall make use of all the rock obtained from the excavation or borrow in accordance with the following provisions.

Rock occurring in the excavation shall be placed to form the base for embankments, to form select embankment layers, to form drainage systems, to form the outer edges of embankments under construction or to widen previously constructed embankments. In all rock slopes, the large rocks shall be placed at the outer face and the smaller rocks and spalls near the centre. The rock shall not be dumped in place but shall be distributed and placed the full width of the lift being formed by blading or dozing in a manner to assure proper placement in the final position in the embankment. The larger rock shall be well distributed and the voids, pockets, and bridging reduced to insure minimum deformation and still permit drainage where required. When there is insufficient material, other than rock, encountered in the excavation to permit the other material being properly compacted in layers, the other material will be reserved to be placed as directed by the Engineer. Material that is too wet to be properly compacted shall not be used to fill the voids of previously placed rock. Unclassified material that meets moisture requirements may be blended with rock and shall be placed in the embankment in lift thickness as prescribed.

To the extent that it is available and needed, sufficient suitable material shall be reserved from the unclassified excavation for use in filling voids in the top of the rock fill.

Where rock is placed on an embankment of other material, the top of the other material shall be sloped from the centre to the sides at a rate of approximately four percent (4%).

In embankment construction subgrade material shall be measured as part of the filling for the embankment construction under Item 207.008 where such unclassified material meets with the Specifications for subgrade material.

Payment for "Selected Material", as instructed by the Engineer, in order to meet the requirements of the Specifications for subgrade material where the unclassified material does not meet the specification shall be measured under Item 207.7.

#### **207.7.3.2 - Lift Thickness:**

The Contractor shall record material type and the lift thickness for all types of embankment. Lift thickness for all material other than for rock shall be 225mm or less.

When embankments are to be constructed across low swampy grounds that will not support the weight of trucks or hauling equipment, the lower part of the fill may be constructed by dumping successive vehicle loads of rock, hard shale or granular material in a uniformly distributed layer. The thickness of a layer shall not be greater than that necessary to support the vehicle placing



subsequent layers, after which the remainder of the embankment shall be constructed in layers and compacted as specified.

In places inaccessible to a roller, such as adjacent to culverts, retaining walls and other structures, the fill material shall be placed in 150 mm compacted layers, uniformly compacted with approved mechanical tampers.

**207.7.3.2.1 - Unclassified Material (Soil, Granular Material and Soft Shale):**

Unclassified material as defined in Section 716 shall be placed in embankments in successive layers not to exceed 150 mm in thickness after compaction. Unclassified material used for embankment fill material shall exhibit a minimum CBR strength of 5% when compacted in accordance with the Specifications.

It is confirmed that the Sub-Section reference number "207.3.2.1" applicable to Unclassified Material (Soil, Granular Material and Soft Shale) on Page 1 of 9 of Bid Addendum No. 1 should be amended to read "207.7.3.2.1".

**207.7.3.2.2 - Hard Shale:**

This material is defined in the applicable provisions of Section 716. When suitable unclassified material is to be mixed with hard shale, this mixture shall be placed in the embankment in lift thicknesses prescribed. Mixtures, which contain 66 percent or more of suitable unclassified material shall be placed in lifts not to exceed 150 mm in thickness after compaction. Mixtures, which contain 35 to 65 percent (by visual inspection), of suitable unclassified material shall be placed in lifts not to exceed 300 mm before compaction. Mixtures, which contain from zero to 35 percent (by visual inspection), of suitable unclassified material shall be placed in lifts not to exceed 600 mm. The lift thickness shall be as thin as the excavated material will permit.

**207.7.3.2.3 - Rock:**

Rock, as defined in Section 716, shall be placed in the embankment in layers of thickness as prescribed.

Mixtures containing 66 percent or more (by visual inspection) of suitable unclassified material shall be placed in lifts not to exceed 150mm after compaction. Mixtures containing 35 to 65 percent (by visual inspection) of suitable unclassified material shall be placed in lifts not to exceed 300 mm before compaction. Mixtures containing zero to 35 percent (by visual inspection) of suitable unclassified material shall be placed in lifts not to exceed 900 mm. The lift thickness shall be as thin as the excavated material will permit.

Rock lifts that are designated as Select Embankment shall contain no more than 15 percent of other suitable embankment material (by visual inspection). The dominant rock size shall be 150 mm and greater.

During excavation and handling, the Contractor shall avoid contaminating the Select Embankment with other embankment materials. Rock for Select Embankment shall be reserved from the excavation up to the Drawing quantity required. If Select Embankment from the excavation is wasted prior to meeting the planned quantities, the Contractor shall be responsible, and bear the expense, for replacing the material wasted up to the Drawing quantity. Rock lifts in embankment shall be placed in approximately level layers of uniform thickness.

The size of the rock lifts shall not exceed 600 mm. The rock shall not be greater in any dimension than 300 mm.

When rock is used as a lining for drainage channels, it shall be placed to the thickness called for on the Drawings or cross sections. The dimensions of the rock may be as large as the thickness of the blanket will permit.

**For Rock Fill in Excavations:**

The first layer of rock shall be placed as a single layer of block or boulders with a minimum thickness of 600 mm. the boulders shall be individually placed in as tight a pattern as possible. The voids between the boulders shall be choked with smaller spalled rock from the excavations that spread over the surface of the large rock and shall be vibrated into the spaces between the blocks/boulders by the passage of equipment.

The surface of the initial rock layer shall be levelled by a joint survey before the next layer is placed and the surface used as a measurement line for the calculation of embankment and excavation quantities. Where requested by the Engineer, trial pits shall be made to verify the thickness is at least 600mm. These shall be made at the Contractors own expense. Measurement for payment of the volume of rock placed in the initial layer shall be the required width of the excavation, which shall be verified during the joint survey, times the theoretical thickness of the layer, i. e. 600mm.

The second layer of rock fill shall be select rock (RCU4) as specified in Table 207.1. It shall be a well graded material from the cut areas or crusher run with a maximum size of 300mm and a median size of 150mm. it shall be placed in 300 mm layer and compacted by 6 passes of a ton vibratory roller to produce a tight dense surface on which the unclassified earth fill may be placed without the need for a geo-textile separator. It shall be placed in 300 mm layer and compacted by 6passes of a 8 tonnes vibratory roller to produce a tight dense surface on which the unclassified earth fill may be placed without the need for a geo-textile separator.



Construction Document

TABLE 207.1 - FILL MATERIALS IN EMBANKMENTS

FILL	DESIGNATION	PAYMENT BASIS	DESCRIPTION	MAXIMUM LAYER THICKNESS (mm)	MAXIMUM AGGREGATE SIZE (mm)	RESTRICTIONS ON USE
	UC 1	Unclassified (207.008)	Suitable unclassified materials per 716.1.1 having CBR value of 5% or more, mixture of any or all of soil, granular material or weathered rock.	150 after compaction	100	Below subgrade layer
	USG	Unclassified for subgrade (207.007)	Granular material per 716.1.2 that can be satisfactorily compacted to a stable condition, having a minimum CBR value of 15%.	150 after compaction	75	Use for subgrade only (top 150 mm of embankment)
	RUC 1	HARD Rock >66% UC1 (207.008)	Hard rock per 716.1.2 mixed with 66% or more of suitable unclassified material.	150 after compaction	100	
	RUC 2	HARD Rock 35% to 66% UC1 (207.008)	Hard rock per 716.1.2 mixed with between 35% & 65% of suitable unclassified material.	300 before compaction	150	Use in lower embankment at least 0.6m below subgrade only
	RUC 3	HARD Rock 0% to 35% UC1 (207.0108)	Hard rock per 716.1.2 mixed with between 0% & 35% of suitable unclassified material.	900 before compaction	450	Use in lower embankment at least 0.6m below subgrade only
	RUC 4	Select Embankment (207.007)	Hard rock per 716.1.2 mixed with between 0% & 15% suitable unclassified material. Dominant hard rock size to be 150mm or greater.	600 before compaction	300	Use as directed by the Engineer
	SSR	SHOT ROCK (217.004)	Shot rock per 704.8 (size > 150 mm)	Not greater than necessary for support per 207.7.3.2 or 207.7.1.	0.5 x permitted layer thickness before compaction	Use only for base of embankment in low swampy ground per 207.7.3.2, or as an initial layer per 207.7.1. Voids in top of each lift to be filled with finer material. The first layer above SSR must be RUC 2 or 3
	SMB	Select backfill underdrains (212.007, 212.008, 212.017, 212.018, 212.022, 212.027, 606.002)	Crushed aggregate per 212.2 and 703.1 except pipe culverts can also be per 704.6	100 after	50	Use only as backfill to structures or underdrains
	PBM	Pipe bedding material (603.014, 603.015, 604.013, 604.014, 604.015)	Per 604.5, Concrete cradle-Class A, Fine aggregate - Class B, or Class 1 or 2 structure backfill-Class C	75mm in soil for RCP. Zero for flexible in soil, 300mm in rock	Fine aggregate - 9.5mm & Class 1 or 2 - 50 mm	Use only as bedding for structures
	SR 1	Special Rock fill (217.001)	Special rock fill per 704.5, size 5 to 40mm	Per Dwg.	N/A	Use per Dwg. 4/SC/004, as directed by the Engineer.
	SR 2	Special Rock fill (217.002)	Special rock fill per 704.5, size 50 to 150mm	Per Dwg.	N/A	Use per Dwg. 4/SC/004, as directed by the Engineer.
	FAF	Fine Aggregate filter per (217.003)	Fine aggregate filter per 704.7	N/A	50	Use as directed by the Engineer.

Notes : (1) Compacted subgrade (228.001) is only in out areas

(2) Embankment fill to be paid as item 207.008 - Unclassified (UC1) except where instructed by the Engineer, when paid as item 207.007 (USG)

**207.7.4 - Compaction of Embankments:**

Embankment material consisting of unclassified material and hard shale as described in Section 716, which does not contain sufficient moisture to be compacted to the requirements specified, shall receive applications of water necessary for compaction. Water shall be applied with suitable sprinkling devices and shall be thoroughly incorporated into the material, which is to be compacted. Embankment and subgrade materials, which contain excess moisture, shall be dried prior to or during compaction, as necessary to obtain satisfactory compaction.

Layers of soil shall be moistened or dried to the tolerance specified in 716.3.1 at the time compactive effort is applied. Water shall be added to or excess moisture removed from soils by the use of ploughs, discs, or other methods.

Each layer of embankment shall be uniformly compacted to the requirements specified in Section 716.

Hard shale shall be broken down in placing by manipulating with tractors, bulldozers, power graders, rollers, or other approved devices until voids between particles are substantially filled. This material shall be compacted and shall be at a moisture content that will provide proper compaction.

Rock shall be placed as required under 207.7.3 and compacted, using the equipment specified in 207.7.5, to the satisfaction of the Engineer.

**207.7.5 - Compaction Equipment:**

Sufficient levelling and compacting equipment shall be provided to do the work of levelling and compacting without delay after the material has been deposited. When the equipment is inadequate for the rate of depositing, the rate of excavation and placement of fill shall be reduced to a rate not to exceed the capacity of the levelling and compacting equipment, with particular attention to the loss of moisture during the delay.

When two or more fills are being constructed and are so isolated from one another that one roller cannot compact the fills satisfactorily, additional rollers shall be provided as ordered by the Engineer.

Vibratory compactors, grid, paddle-foot, or vibratory rollers, or other compacting equipment approved by the Engineer, shall be used for fills constructed of materials, which are predominately rock or hard shale.

Approved pneumatic or power driven backfill tampers shall be used in areas inaccessible to rollers.

Three-wheel rollers shall weigh not less than 9 Mg. They shall be of sturdy construction and especially designed for heavy work. They shall be in good mechanical condition and have sufficient power to travel over rough surfaces and steep grades.

Pneumatic tired rollers shall operate on two axles in such manner that the rear group of tires will not follow in the tracks of the forward group. They shall be mounted on a rigid frame and have a loading platform or body suitable for ballast loading. The pneumatic tired rollers, under working conditions, shall have a minimum rolling width of 1.5 metres and shall give a minimum compression of 80 N/mm of width of tire tread.

Single axle pneumatic rollers of an approved type may be used, providing the requirements as to width and compressions per mm of width of tire tread are met.

Tamping rollers shall consist of metal rollers, drums, or shells surmounted by metal studs with self-cleaning tamping feet. The cross sectional area and spacing of tamping feet and the weight of the roller shall be such that the compaction or density for the particular material shall be obtained as specified.

Each tamping roller shall consist of at least two sections not rigidly joined. Grid rollers shall consist of drums at least 1.5 metres in diameter whose cylindrical faces present the appearance of an open woven bar mesh.

Each drum shall be at least 750 mm long and they shall be independently mounted close together on the same axle. The complete roller, when operating without ballast, shall weigh not less than 5.4 Mg or 70N/mm of length of roller drum.

Arrangements shall be provided for adding ballast, as directed by the Engineer, to such an extent that the total weight of the unit can be increased to at least 13.5 Mg and 80 N/mm of length of roller drum. Grid rollers shall make at least three complete passes of each layer or until the required density is obtained.

The use of trucks, carryalls, scrapers, tractors, tractor wagons, or other haulage equipment shall not be considered in lieu of compacting equipment prescribed, but the traffic of such hauling equipment shall be distributed over the fill in such a manner as to make use of the compaction afforded as an addition to compaction by rolling or vibrating.

#### **207.8 - FINISHING EARTH ROADS:**

When no pavement or surfacing is included in the Contract, the roadway shall be finished as a graded earth road. The roadway, shoulders, and super elevated curves shall be constructed simultaneously to the required cross section and grade. Unsatisfactory or unsuitable material shall be removed and replaced as specified in 207.9. The entire surface shall be brought to a smooth condition by repeated use of an approved power grader and continuously maintained in a condition suitable for traffic until final completion and acceptance of the work. When grading work is being executed simultaneously on more than one section of a Contract, an approved grader shall be furnished on each section if so required by the Engineer.

#### **207.9 - SUBGRADE:**

The subgrade shall be constructed in accordance with these Specifications, in substantial conformity with lines, grades, and cross sections shown on the Drawings or established by the Engineer. The level tolerance shall be plus or minus 13mm.

The sub grade shall be 150 mm compacted thickness for all embankment and excavation sections and shall be constructed out of suitable material free of particles larger than 75 mm and consisting of granular material, conforming to the requirements of 716.1.1.2, that can be satisfactorily compacted to a stable condition. The tolerance set forth in 314.6 shall apply. Excavation to the 150 mm limit in cut sections will be paid for at the contract unit price bid for "Rock Excavation" or "Unclassified Excavation" as determined by the Engineer. Material used for subgrade construction shall exhibit a minimum CBR strength of 15% when compacted in accordance with the Specifications. Material used for the subgrade construction shall exhibit a PI not greater than 15.

## Construction Document

---

Excavation made below this 150 mm limit in cut sections will not be measured or paid for, except, when unsuitable material is removed as directed by the Engineer.

Measurement and payment for removal of 300mm unsuitable material (or greater) with the actual locations and depth of removal directed and/or approved by the Engineer shall be paid for at the unit prices for both excavation and disposal of "unsuitable material". Also the additional replacement quantity shall be measured and paid for separately.

The subgrade layer or layers shall be moistened or dried to uniform moisture content suitable for maximum compaction and brought to a firm unyielding condition by compaction. The subgrade shall be uniformly compacted to the applicable requirements specified in Section 716.

The surface of the subgrade shall be maintained in such condition that it will drain at all times.

When trenching is executed for narrow base widening, ditches of an adequate depth shall be constructed across the shoulders at sufficient intervals to permit a free outlet of water. Equipment or vehicles shall not be allowed to travel in a single track and form ruts in the subgrade. Any ruts or irregularities formed in the subgrade shall be scarified and re-compacted.

When the construction of a base, pavement, or surface is included in the Contract, or is so provided on the Drawings, the profile grade of the subgrade shall be such that the specified thickness of the base course, pavement and surface will be obtained within limits of final surface grade. Any grade revision necessitated shall be called to the attention of the Engineer.

When so designated, engineering fabric for subgrade stabilization, conforming to 715.11, shall be installed over the area, which shall be relatively smooth, free of sharp protrusion, depressions or debris. The fabric shall be placed with the machine direction of the fabric parallel with the alignment and shall be relatively smooth and free from creases. The joining of fabrics shall be accomplished by sewing (either in the field by portable sewing machine or during manufacture of the fabric) as outlined in 715.11.3 or shall be installed so any splice joints have a minimum overlap of 900 mm or as directed by the Engineer.

Once the fabric is placed, cover material shall be brought to the working face, dumped and spread with equipment exerting the minimum ground pressure possible. Construction equipment shall not operate directly on the fabric. A minimum of 150 mm of cover material shall be maintained between the construction equipment and the fabric.

Compaction shall be accomplished by conventional methods after the cover material is spread, sheepfoot rollers will not be permitted.

The completed subgrade shall be to an uniform appearance, and shall be checked for conformity to the lines, grades and dimensions shown on the Drawings.

Where the Drawings indicate the need for engineering fabric for either subsurface drainage, or separation, the material shall conform to 715.11 and be placed as fabric for stabilization, except the fabric may be joined by overlapping so the splice joints have 600mm minimum overlap. Construction equipment is permitted on the fabric provided all damage is repaired as specified in 715.11.3. When the fabric is placed in structure backfill applications, such as bridge abutments, the Engineer will direct the orientation of the fabric.

Handwritten signature or initials, possibly "Bd" followed by a flourish.



**207.10 - SHOULDERS:**

Before any base or pavement may be placed upon the subgrade, the shoulders along and adjacent thereto shall be built to the dimensions shown on the cross section. In order to provide adequate side support for macadam or other stone types of base or surface, shoulders shall be constructed full width, substantially to line and grade and to the depth of the course being constructed, and compacted with at least a 9 Mg roller, and then trimmed to the required line. The Engineer may require that the Subbase and base for the shoulder be constructed concurrently with that of the roadway. When concrete base or pavement is being constructed, or where the shoulders are to be built of stabilized material, these requirements may be waived by the Engineer.

Upon completion of the base, pavement, or surfacing, the shoulders shall be finally shaped, dressed, and compacted to conform to the dimensions shown on the Drawings. No stone exceeding 75mm in maximum dimension will be permitted within 75mm of the surface. The outer edge of the shoulder shall be trimmed to a neat line parallel with the centreline of the roadway, and the entire surface rolled to within 300 mm of the outside edge, refilling and re-rolling any depressions that develop. Ditches and back slopes shall be finally cleaned and trimmed to line upon completion of the shoulder work.

The in-place density of shoulders shall be as specified for the subgrade in Section 716.

**207.11 - DRAINAGE:**

When grading, sub-grading, constructing shoulders, or placing base or pavement is suspended because of unsuitable weather, or any other reason, suitable provisions shall be made to drain the grade, subgrade or shoulders by means of the construction of adequate side ditches and drains. The ditches and drains shall be kept open and maintained during the period of suspension, including the removal of slides. Upon failure of the Contractor to construct and maintain the temporary drains prior to the acceptance of the work, the Engineer may cause such work to be executed by others, and the cost will be deducted from moneys due the Contractor.

Upon completion of the subgrade or shoulders and before any base or pavement is placed, subgrade drains or weeps shall be placed as shown on the Drawings or as directed by the Engineer in accordance with Section 606.

**207.12 - TEMPORARY SURCHARGE:**

When shown on the Drawings or directed by the Engineer, a temporary surcharge composed of suitable compacted material from the "Unclassified Excavation" or "Unclassified Borrow Excavation" shall be placed after completion of the embankment to the elevations of the base of the subgrade.

The temporary surcharge shall be placed in accordance with location limits and elevations shown on the Drawings or as directed by the Engineer. Surcharge material shall be placed in accordance with the provisions of 207.7. The first 1.5 metres of the surcharge shall be compacted as specified for embankment in the applicable provisions of Section 716. The remaining surcharge shall be compacted as specified above except that the target percentage of dry density shall be 90 percent.

The surcharge shall be maintained for the period indicated on the Drawings or as directed by the Engineer.



With regard to the Technical Specifications Sub-Section 207.12, "Temporary Surcharge", the duration for which the temporary embankment surcharge material shall remain in place in any particular location shall be determined by the Engineer depending on the nature of the settlement observed.

The Engineer will arrange for the monitoring of the settlement of surcharged sections of embankment in liaison with the Contractor. The Contractor shall cooperate with the Engineer in organizing his work operations such as to not disturb the Engineer's monitoring equipment and gauges.

Placement of surcharge material shall be measured as "Filling with Unclassified Material". Removal of surcharge material (as appropriate) shall be measured as Unclassified Excavation.

### **207.12.1 - EMBANKMENT, PRELOADING AND WICK DRAINS:**

1. Prior to placing the working platform, a geotextile separation layer shall be laid on the ground surface. Prior to laying the geotextile, any trees, bushes or other obstructions shall be removed. The ground surface shall be reasonable uniform and any irregularities which may cause local stressing of the fabric shall be evened out.
2. The working platform shall consist of earthfill (UC1) and be placed in such a manner to avoid overstressing of the soft subsoil or the formation of a bow wave in front of the advancing fill as described in BS 8006:1995. Earthfill shall be dumped well behind the advancing face of the fill that shall then be spread to specified level by light-weight dozer.
3. the top of the existing working platform shall be shaped to conform with the following:
  - the height of fill at the outer edge will be 0.75m above GL,
  - the fill will slope at 2% from the centerline to the edges, and the height in the centre of the embankment will be about 1.2m above GL,
4. The berm widths shall be as shown on the drawings.
5. Side slopes will initially be 1:1.5, but this will change after consolidation of the embankment.
6. When the working platform has been placed, the first 150 mm layer of the drainage blanket will then be spread prior to the installation of wick drains.
7. Wick drains will then be installed as shown on the drawings. Wick drains shall be installed down to the bottom of the soft sub soil stratum. The actual depth shall be determined in the field from the penetration resistance of the mandrel and may be estimated from the borings and piezocone testing. It may be assumed that the level of the firm stratum to which the wick drains are to be taken is the level at which the piezocone tip resistance exceeds 1 Mpa continuously over a depth increment of at least 1 metre.
8. The wick drains shall be cut off 300mm above the surface and bent over prior to placing the second layer of the drainage blanket.
9. Immediately after installation of the wick drains, the piezometers will be installed at the locations given on the drawings or as instructed by the Engineer.
10. After the piezometers are installed, the second 150 mm layer of drainage blanket will be laid.

11. A single layer of geotextile 600/50 or similar approved geotextile shall be laid on top of the drainage blanket. The material shall be laid in accordance with the manufacturer's recommendations and the provisions given in BS8006:1995. It shall be laid so that the longitudinal direction of the warp is in the direction of maximum tensile stress, ie. perpendicular to the side slope or end slope of the embankment. The material shall be laid over full width of the embankment preferably in one piece, but where joints are unavoidable, they shall be made to give full strength transfer across the joint as shown on the drawings. Only nominal overlap between adjacent strips will be required.
12. Where the new embankment is an extension of the existing Stage 1 embankment, the new geotextile membrane shall be joined to the existing membrane in accordance with the joint detail shown on the drawings.
13. When the geotextile has been laid, filling with UC1 may commence. Filling will take place at a controlled rate so that the ratio of excess pore pressure head to fill load  $r_u$  does not exceed 0.5, unless otherwise instructed. It is estimated that this condition will be satisfied by placing one 200 to 500 mm layer of fill per week. Compaction of embankment and preload fill will be in conformance with clause 207.7.3 of the specifications.
14. The initial top levels of the berms and preload have been given on the drawings. The initial preload levels have been determined such that the final levels after consolidation (at the 90% consolidation stage) they are 1.33 x Final Grade level.
15. As settlements occur during the filling operation, the degree of consolidation and the remaining consolidation will be determined from the piezometer readings. The levels to which the preload fill will be placed may be adjusted by the Engineer on the basis of the pore pressure readings and remaining consolidation to give final levels defined above.
16. The preload will remain until 90% of the consolidation settlements have taken place. This will be determined by the pore pressure readings from the piezometers. The wick drains have been designed so that the period from the time the preload has been placed to full height to the time when the preload can be removed is approximately 6 months. The preload fill will be then removed down to formation level and the fill material placed in the Phase 2 area adjacent to the right-hand berm.

#### 207.12.2 - INSTRUMENTATION

Instrumentation shall comprise piezometers, settlement plates, toe stakes and settlement blocks. These shall be installed at the locations given on the drawings.

##### a. Piezometers

At the stations specified, hydraulic piezometers shall be installed beneath the fill and one open standpipe piezometer shall be installed 5m outside the left toe of berm.

Hydraulic piezometers shall be Soil Instruments push-in Type 1.12 or similar with high air entry filters. Open standpipe piezometers shall be the standard Casagrande type. Both types of piezometer shall be installed in the bottom of cased borings and sealed with a bentonite slurry. Hydraulic piezometers shall be installed to depths shown on the drawings or as directed by the Engineer.

All open standpipes shall be installed with tips at - 3m.

At each station where piezometers are installed, a read-out cabinet shall be provided serving all the piezometers installed at that station. The readout pressure transducers and deairing buss shall be mounted on a panel in a secure cabinet provided with a door and lock prevent unauthorised

tampering with the instruments. The height of the cabinet should be about 1.2m off the ground to allow ease of reading and maintenance. The piezometer tubing should be in conduit right into the cabinet, which should be sturdily mounted on wooden or steel stakes driven well into the fill. The gauges should be mounted on a suitable board to which all leads are securely fixed and clearly marked with station, piezometers number and depth. The cabinet should also have a specific properly fixed levelling point so that the gauges can be referenced to the level of the fixed point.

#### **Installation of hydraulic piezometers**

1. Before installation, the piezometers shall be de-aired in accordance with the procedure given in the supplier's manual.
2. Installation procedures shall follow the supplier's recommended practice.
3. Piezometers shall be installed in cased borings. Before installing the piezometer, the borehole shall be carefully cleaned out to the bottom of the casing. Care shall be taken to ensure that borings are located midway between adjacent wick drains.
4. The piezometer shall then be pushed into the bottom of the borehole using the special tool provided by the supplier.
5. The casing shall be filled with a bentonite slurry to the top of the borehole before the casing is removed.
6. The piezometer tubing shall be laid in a 200 mm deep trench to the read-out cabinet. The tubing shall be laid in conduit and covered with 100 mm of quarry dust. Care should be taken to insure the tubing is not damaged or kinked during installation.
7. After installation, the piezometer shall be flushed with de-aired water until all air bubbles are removed from the system.
8. An initial reading of the pore pressure shall be taken immediately after installation.
9. Pore pressures shall be recorded on forms provided by the Engineer and readings shall be taken at the same time as adjacent settlement plate readings so that fill levels, gauge levels and settlements can be recorded simultaneously.
10. Unless otherwise instructed, readings shall be taken daily during filling operations, and weekly during the first month after filling has been completed. Thereafter, readings shall be taken fortnightly.
11. The results shall be submitted to the Engineer in hard copy and on diskettes in Excel format.
12. Installation and de-airing of the first two piezometers shall be done under the supervision of the supplier's specialist.

#### **b. Settlement plates**

Settlement plates have been installed at ground level at 25 stations between km 59.5 and 61.0 to measure the settlements beneath the fill. Additional settlement plates shall be made up and installed as shown on the drawings at the stations shown. A typical detail of a settlement plate is shown on the drawings. It comprises a 600 x 600 x 5 mm thick steel plate in the centre of which is welded a 25 mm ID water pipe. The water pipe is 1500 mm long and is provided with 1m long extension pieces, added as the fill is placed. Pipe extensions shall be joined to the section below by pipe unions and the joints firmly screwed together. Whenever adding an extension piece, care shall be taken not to disturb the pipe section below. The top of the pipe shall be levelled before and after each extension is added.

The water pipe shall be surrounded by a sleeve of 100 mm PVC pipe which is installed some distance above the plate so that downwards friction caused by compaction of the fill does not cause settlement of the plate. The sleeve shall be extended in one metre lengths whenever the central pipe is extended.

**c. Toe stakes**

Toe stakes shall be installed 3m from the toe of each berm at each instrumentation station and shall be used to monitor possible horizontal movement of the ground due to shear deformations from the fill. The stakes shall comprise 3m long 1 inch diameter steel pipes pushed 2 m into the ground. The pipes shall be fixed by 500 x 500 x 200 mm concrete blocks cast insitu around the pipes at ground level.

**d. Settlement blocks**

Settlement blocks are intended for the long term monitoring of post construction settlements by RDA in areas where preloading has been undertaken. They shall be set along critical sections at 100 m intervals at each edge of shoulder on the completed subbase surface with their top face flush with the final shoulder AC. Settlement blocks shall consist of 300 x 300 x 150 mm concrete blocks with steel bolts or spuds cast into the centre of their top faces.

Where ordered by the Engineer, additional settlement blocks may be required to be installed in the preload fill to supplement the settlement plate data.

**207.13 - PROTECTION OF CURTAIN WALLS:**

All bridges which will be used for permissible haulage, but which do not have the approach slabs constructed, shall have the pavement notch of the curtain walls built up to final grade by the use of timber to eliminate the possibility of damage to the curtain walls.

**207.14 - SLIDES AND SLIPOUTS:**

If, the Engineer is of the opinion that, material outside the planned roadway (or ditch slopes) is unstable; constitutes a potential slide area; material from slides has come into the roadway (or ditch), and/or material has slipped out of new or old embankments, the Contractor shall be instructed to re-excavate to designated lines or slopes, either by benching or in such manner as directed by the Engineer. Such material shall be used in the construction of the embankments and in flattening of slopes, or disposed of as directed by the Engineer.

Erosion, regardless of amount or extent, caused by the action of the elements and which results in damage to the work or materials shall in no case be considered a slide or slip- out.

**207.15 - METHOD OF MEASUREMENT:**

The quantity of work executed will be measured for "Unclassified Excavation", "Unsuitable Excavation" or "Rock Excavation", according to their material definitions. Material volumes will be measured as excavated from its original position and determined from the approved cross sections by the average end area method computed using a Computer Program. No material removed beyond the slope lines or below the grade line shown on the Drawings, except as provided in 207.3.4 and 207.9, will be included for payment unless authorized in writing by the Engineer. Slides and material removed from beyond the slope lines, not attributable to carelessness, overshooting, or unsuitable construction methods on the part of the Contractor, will be included only when so authorized by the Engineer.

Excavation below grade, including undercutting, as shown on the Drawings or as directed by the Engineer; ditches to divert water from the slopes of cuts; inlet and outlet ditches for drainage



structures; other ditches as authorized by the Engineer; removal of topsoil, sod, old pavement, boulders, walls, and other unsuitable material within the areas upon which the embankment is to be placed; benching; and all other excavation authorized but not shown by the cross sections, will be measured separately and included for payment.

Where stone base or concrete pavements have been scarified or broken (but not removed), slopes other than rock upon which embankments are to be placed ploughed or scarified, loose soil been manipulated and compacted (but not removed), such work and all the work of placing and compacting all embankments, widening or waste pits, placing and consolidating rock fills, will be considered as a necessary part of manipulation, the cost of which is included in the price bid per cubic metre for "Unclassified Excavation".

An isolated volume of artificial hard material or rock occurring within other material to be excavated shall not be measured separately unless its volume exceeds  $1.0\text{m}^3$ , except that the minimum volume shall be  $0.25\text{m}^3$  where the net width of excavation is less than  $2.0\text{m}$ .

Payment for placing and removal of temporary surcharge will be measured in Cubic metres for both "Placing of Surcharge" and "Removal of Surcharge" material.

Placement of surcharge material shall be measured as "Filling with Unclassified Material". Removal of surcharge material (as appropriate) shall be measured as Unclassified Excavation.

The removal and disposal of slide and slip-out material in accordance with 207.14 will be paid for at the contract price for "Unclassified, Unsuitable and/or Rock Excavation" as per their pertinent definitions. The cost of any work outside the limits of the slide necessary to make slide or slip-out areas accessible to normal excavation equipment will be paid for as above. However, the above provisions shall not be so construed as to relieve the Contractor from the duty of maintaining all slopes true and smooth.

The quantity of subgrade work executed under this item will be the number of cubic metres of "Subgrade" placed to the lines, dimensions and cross sections shown on the Drawings or designated by the Engineer.

Subgrade constructed outside the lines, dimensions and cross sections shown on the Drawings or designated by the Engineer will not be measured for payment.

Measurement and payment for finishing shoulders and ditches will be accordance with Section 229 and Section 308.

Measurement and payment for under drains will be in accordance with the provisions of Section 606.

The embankment material will be measured in its final compacted position in the roadway.

Measurement will be made upward from the original ground line without any allowance for subsidence due to compaction of the base under the embankment. The original cross sections will be used for determination of volumes of embankment material placed, unless changes have been directed.

The embankment material may comprise both roadway excavated and borrowed material and measured in its final compacted position. Deficient quantity furnished from borrow pits for embankment filling, will be measured as per Section 211.

Items for filling shall be deemed to include compaction.



Water furnished for embankment compaction will not be measured separately but included in unit cost.

Items for excavation shall be deemed to include upholding sides of excavation, additional excavation to provide working space and removal of dead services.

The quantity of engineering fabric placed in subgrade stabilization or subsurface drainage or separation will be measured by the square metre complete in place and accepted, excluding laps.

In embankment construction subgrade material shall be measured as part of the filling for the embankment construction under item 207.008 where such unclassified material meets with the Specifications for subgrade material.

Payment for "Selected Material", as instructed by the Engineer, in order to meet the requirements of the Specifications for subgrade material where the unclassified material does not meet the specification shall be measured under item 207.7.

All approved excavation will be measured and paid for under the appropriate items in the Bills of Quantities. There will be no charges levied on the Contractor for the use of material originating from within the Right-of-Way boundaries and whose use is approved by the Engineer in accordance with the Contract. Should the Contractor, with the Engineer's approval, elect, (and receive the necessary approvals and permits from the local statutory authorities) to use material originating from outside the Right-of-Way boundaries it shall be deemed that all costs in respect of (but not limited to) such matters as rents, permits, royalties and other levies in connection with the use and working of such material sources outside the Right-of-Way boundaries shall have been provided for by the Contractor in the rates entered against the appropriate items in the Bills of Quantities

The quantity of rock estimated as being required for crushing for aggregate has been separated from the other quantities for earthworks in the Bills of Quantities. Excavation of rock for crushing for use as aggregates shall be measured under Item 207.003 of the Bills of Quantities, and shall include for haulage to the crushing plant. The measurement for the incorporation of such aggregate material into the Works shall be made under the other items of the Bills of Quantities relating to the various components of the Works for which such aggregate is utilized, and the rates which shall have been entered by the Contractor against those items will be deemed to include for all necessary operations (including, but not limited to, crushing and haulage) required to produce the said aggregate in its final location in the Works.

Bill of Quantities Item 211.002 "Rock borrow excavation" is a provisional item. Its intention is to provide a contingency allowance for the Engineer to utilize or not for the excavation of rock material from outside the Right-of-Way boundaries, as he shall deem appropriate.

Placement of surcharge material as referred to in Question 38A shall be measured as "Filling with Unclassified Material". Removal of surcharge material (as appropriate) shall be measured as Unclassified Excavation.

The quantity of engineering fabric placed in subgrade stabilization or subsurface drainage or separation will be measured by the square metre complete in place and accepted, excluding laps.

**207.16 - BASIS OF PAYMENT:**

The quantities, determined as provided above, will be paid for at the contract unit prices bid for these items, which prices and payments shall be full compensation for doing all the work prescribed in a workmanlike and acceptable manner, including all labour, tools, equipments, supplies, haulage, and incidentals necessary to complete the work.

The cost of excavation includes the up holding sides of excavation, additional excavation to provide working space, removal of dead services, dewatering, preparation of excavated surfaces, shoring, sheet piling, trimming of excavated surfaces hauling of all material, any reserving and re-handling of excavation material. The cost of embankment construction including compaction, furnishing and applying water as an aid to embankment compaction, preparation of surfaces for embankment filling and the cost of furnishing additional waste sites, grading, fertilizing, and seeding and mulching of all waste sites, which shall be included in the unit prices in the bid.

The cost of furnishing all materials, including furnishing and applying water necessary as an aid to subgrade compaction, shall be included in the unit price bid for "Subgrade"

**207.17 - PAY ITEMS:**

ITEM	DESCRIPTION	UNIT
207.001	Stripping and stockpiling topsoil	Cubic metres
207.002	Unclassified excavation	Cubic metres
207.003	Excavate rock (to crusher plant)	Cubic metres
207.003a	Load and haul rock stockpiles in North section for crusher plant. (Provisional)	Cubic metres
207.004	Excavate rock (to embankment)	Cubic metres
207.004a	Load and haul rock stockpiles in North section for embankment (provisional)	Cubic metres
207.005	Excavation unsuitable soil	Cubic metres
207.005a	Excavate unsuitable soil 0m to 3m depth	Cubic metres
207.005b	Excavate unsuitable soil 3m to 6m depth	Cubic metres
207.005c	Excavation unsuitable soil over 6m depth	Cubic metres
2007.005d	Disposal of excavated unsuitable material beyond 5km from Exit point of the ROW	Cubic metres
207.006	Excavation for slips and slides (provisional)	Cubic metres
207.007	Filling with selected material (provisional) using ROW material	Cubic metres
207.007a	Filling with selected material using material from borrow	Cubic metres
207.008	Filling with unclassified material using available material with in ROW	Cubic metres
207.008a	Filling with unclassified material from borrow	Cubic metres
207.009	Geotextile material class B for embankment	Square metres
207.010	High strength geotextile (200/50) (provisional)	Square metres
207.011	High strength geotextile (600/50) for embankment	Square metres

Pay Items for the "Section 207.12 – Temporary Surcharge" shall be given under section 606.11.

Bidders are required to make their own assessment of the split between the different types of component of "unclassified material" based upon the geological and geotechnical information supplied to them (as information only) with the bidding documents, supplemented by their own observations at the site of the works.

The extent of the excavation shall be as shown in that drawing or as otherwise specifically instructed by the Engineer. The Contractor shall be paid for such excavation under Item 207.005 of the Bills of Quantities for excavation to the extent shown on the typical drawing or as otherwise instructed by the Engineer.

The provision of suitable sites for the permanent deposition of material to be disposed of shall be the responsibility of the Contractor. No specific payment shall be made to the Contractor in respect of the provision of such sites, and he shall comply in all respects with the requirements of the local government authorities and the Central Environmental Authority.

Future interchange sites may be used for the temporary stockpiling by the Contractor of material for use in the Works, with the approval of the Engineer. It should be noted by bidders that the 'future interchange' denoted at approximately Km 27+900 has been withdrawn as a 'future interchange' and, accordingly, the land which was to have been reserved for that interchange will not be available for such temporary stockpiling.

Permanent disposal of material within the Right-of-Way will generally not be allowed. Any dispensation in this respect will be subject to the approval of the Engineer in the specific circumstances of such disposal.

Item 207.001 covers the stripping of topsoil from on-Site sources and its stockpiling for subsequent use in the Works.

Item 651.001 covers the furnishing and placing of topsoil where topsoil shall have to be obtained from an off-Site source.

651.002 covers the obtaining of topsoil previously stockpiled from excavation for the Works and its incorporation into the finished Works.]

In embankment construction subgrade material shall be measured as part of the filling for the embankment construction under Item 207.008 where such unclassified material meets with the Specifications for subgrade material.

Payment for "Selected Material", as instructed by the Engineer, in order to meet the requirements of the Specifications for subgrade material where the unclassified material does not meet the specification shall be measured under Item 207.7.]

All approved excavation will be measured and paid for under the appropriate items in the Bills of Quantities. There will be no charges levied on the Contractor for the use of material originating from within the Right-of-Way boundaries and whose use is approved by the Engineer in accordance with the Contract. Should the Contractor, with the Engineer's approval, elect, (and receive the necessary approvals and permits from the local statutory authorities) to use material originating from outside the Right-of-Way boundaries it shall be deemed that all costs in respect of (but not limited to) such matters as rents, permits, royalties and other levies in connection with the use and working of such material sources outside the Right-of-Way boundaries shall have been provided for by the Contractor in the rates entered against the appropriate items in the Bills of Quantities

The quantity of rock estimated as being required for crushing for aggregate has been separated from the other quantities for earthworks in the Bills of Quantities. Excavation of rock for crushing for use as aggregates shall be measured under Item 207.003 of the Bills of Quantities, and shall include for haulage to the crushing plant. The measurement for the incorporation of such

aggregate material into the Works shall be made under the other items of the Bills of Quantities relating to the various components of the Works for which such aggregate is utilized, and the rates which shall have been entered by the Contractor against those items will be deemed to include for all necessary operations (including, but not limited to, crushing and haulage) required to produce the said aggregate in its final location in the Works.

It is confirmed that all excavated rock measured under Bill of Quantities Item 207.004 shall be transported for use for embankment fill. The quantity given in Bill of Quantities Item 207.004 of the bidding documents is only an indicative assessment of the anticipated needs of the Works, and the actual quantity required for the Works may differ. The use of this material for embankment fill shall be measured under Item 207.008 "Filling with unclassified material".]

In the event that the Engineer shall conclude that there will be a shortfall in the availability of "rock" material for crushing for the requirements of the Works from excavation within the boundaries of the Right-of-Way (in accordance with the provisions defined elsewhere in the bidding documents in respect of availability of material from within the Right-of-Way boundaries) he shall instruct the Contractor to supply the necessary balance of "rock" material from borrow areas which the Contractor shall have located outside the boundaries of the Right-of-Way. Such material, in excess of any quantity (if any) from sources within the Right-of-Way boundaries that the Engineer shall judge that the Contractor shall have wasted, shall be measured under Item 211.002 of the Bills of Quantities. Such borrowed material (if any) which shall be deemed to substitute for any of the aforementioned "wasted" material shall be measured under Item 207.003.

It is intended that all hard rock material shall be obtained from within the Right-of-Way boundaries. In the event of any shortfall the rock material would have to be borrowed from outside the boundaries for the Right-of-Way.

**SECTIONS 208 - 210: Not Used**



**SECTION 211  
BORROW EXCAVATION**

**211.1 - DESCRIPTION:**

"This work shall consists of excavating, transporting and depositing material from borrow areas required to complete the roadway and embankments. The work shall also include reinstatement of depleted borrow areas. It shall be the Contractor's responsibility to provide the necessary material with which to construct the works. The Contractor shall be free to obtain material from borrow areas in compliance with provisions of Clause 211.3".

Bidders attention is drawn to the upper typical cross section on Drawing. The typical cross section illustrates that various segments of cutting for subsequent road development construction stages (consisting of future road widening) may be utilized for the production of additional material where there is a shortfall of material for the construction of embankment fill. Limits are indicated in the Plan and Profile drawings. The approval of the Engineer shall be obtained for such widening of cuttings where widening is not indicated in the drawings as a requirement of the Works, and such approval will not be unreasonably withheld.]

It is the Employer's intention that the Contractor shall make full use of materials from within the Right-of-Way for the construction of the Works. Notwithstanding this it shall be the Contractor's responsibility to provide the necessary material with which to construct the Works. Should a bidder consider that there will be a shortfall of material from within the Right-of-Way from which to construct the Works he shall make provision in his bid for the obtaining of supplementary material from sources outside the Right-of-Way.

**211.2 - MATERIALS:**

**211.2.1 - Unclassified Borrow Excavation:**

Materials shall be obtained which are suitable for the particular purpose for which unclassified borrow excavation is authorized.

**211.2.2 - Rock Borrow Excavation:**

Material shall meet the requirements specified for Rock in 207.7.3.2.3. In addition, the Selection and operation of quarries shall be complied with the current legislation and regulations governing operation of quarries.

**211.2.3 - Select Borrow Excavation:**

Material shall consist of a granular material as defined in 716.1.1.2 unless otherwise specified in the Contract.

No borrow pit may be opened to obtain sand or gravel unless a shortfall of rock excavation occurs for on site crushing of fine aggregates.



## CONSTRUCTION METHODS

### 211.3 - GENERAL:

All borrow excavation materials shall be obtained in the amounts directed, by the methods and subject to the same provisions as prescribed in Section 207 except as modified or amended. "Borrow excavation should not be placed until after the roadway excavation and material remaining in the Stage 1 haul road has been utilised in the embankments and there is no likelihood of slips or excess material". The work shall also include reinstatement of depleted borrow areas all to the requirements of relevant authorities.

The Contractor shall submit to the Engineer for review and approval of a Method Statement for borrow excavations, which should in detail cover opening, using and closing stages, also all environmental impact aspects.

No borrow area shall be opened until authorized by the Engineer.

The Contractor will not be allowed to operate any borrow pit without holding proper licenses required by the current legislation.

The borrow sites should get Local Authority Approval, Geological Survey and Mines Bureau Licenses for quarrying and Environmental Protection License from Central Environment Authority and permits for the use of explosives and any other approval or license that may be required.

The cost of any investigation and obtaining licenses would be borne by the Contractor. As obtaining of permits and licenses may take time, the Contractor should well aware beforehand to program and arrange such work without affecting the normal progress of the site.

The Contractor will be responsible for renewal of those licenses in time or even selection of another borrow site if renewal of licenses will be rejected.

Probable sites that could require an investigation are flood plains of major rivers and large rock shelters. Non-probable locations of cultural resources would be steep hillsides and/or narrow valleys.

Temporary roads, haul roads, or other facilities, which may be required for the use or convenience of the Contractor in excavating and transporting borrow material shall be provided by the Contractor without cost to the Client.

Materials shall be obtained from borrow pits in a workmanlike manner to minimize pollution or sedimentation of streams, lakes, and reservoirs and to facilitate the work of measuring and calculating the volume of material removed.

Borrow pits shall not be excavated below the level of the natural drainage for the area, and the drainage ditches required to keep the pit free from standing water during the progress of the work and upon completion shall be constructed without extra compensation.

Upon completion of the work, the borrow pit shall be neatly trimmed and all debris and soil disposed of in an acceptable manner. Borrow pits shall be graded, fertilized, seeded and mulched in accordance with Section 652.



**211.4 - UNCLASSIFIED BORROW EXCAVATION:**

Unclassified borrow excavation shall consist of material, as prescribed, incorporated into embankments, backfill, shoulders, or any other type of work shown on the Drawings or designated by the Engineer. The method of placement, compaction and density shall be in accordance with the applicable requirements of 207.7.

**211.5 - ROCK BORROW EXCAVATION:**

Rock borrow excavation shall consist of materials, as prescribed, incorporated into embankments in accordance with the provisions of 207.7 covering the construction of rock fills.

**211.6 - SELECT BORROW EXCAVATION:**

Select borrow excavation shall consist of material as prescribed, incorporated into embankments, backfills, shoulders, or any other type of work shown on the Drawings or designated by the Engineer. The method of placement, compaction and density shall be in accordance with the applicable requirements for granular material as prescribed under 207.7.

**211.7 - METHOD OF MEASUREMENT:**

**211.7.1 - Cubic Metre Measurement:**

The quantity of work executed will be measured in cubic metres actually obtained and incorporated in the work, determined in its placed and compacted final position from cross sections by the average end area method.

The volume measured for excavation within borrow pits, shall be the net volume measured for filling based on the end area method. Items for excavation within borrow pits shall be deemed to include removal and replacement of overburden and unsuitable material.

If the borrow is obtained in such quantity or in such manner that a waste of unclassified excavation, slips, or excess material is caused, the amounts of such waste shall be deducted from the borrow volume. In determining the amount of material to be developed due to unauthorized placement of borrow material or unclassified excavation material in the embankments, the quantity outside the construction tolerance will be measured and deducted from borrow on a metre to metre basis without adjustment due to shrinkage or swelling.

If further borrow material is required the quantity over-hauled material shall be from the centre of the borrow area to the nearest point of entry to the site. The amount of over-haul shall be determined by measuring in cubic metres the quantity placed and compacted in its final position in accordance with the requirements of 207.7.

**211.8 - BASIS OF PAYMENT:**

The quantities, determined as provided above, will be paid for at the contract unit price bid for these items, which unit prices and payments shall be full compensation for doing all the work prescribed in a workmanlike and acceptable manner, including all labour, tools, equipment, supplies, haulage and incidentals necessary to complete the work. There will be no additional compensation for furnishing, grading, fertilizing, seeding and mulching of borrow pits.



**211.9 - PAY ITEMS:**

ITEM	DESCRIPTION	UNIT
211.001	Unclassified borrow excavation	Cubic metre
211.002	Rock borrow excavation	Cubic metre

All approved excavation will be measured and paid for under the appropriate items in the Bills of Quantities. There will be no charges levied on the Contractor for the use of material originating from within the Right-of-Way boundaries and whose use is approved by the Engineer in accordance with the Contract. Should the Contractor, with the Engineer's approval, elect, (and receive the necessary approvals and permits from the local statutory authorities) to use material originating from outside the Right-of-Way boundaries it shall be deemed that all costs in respect of (but not limited to) such matters as rents, permits, royalties and other levies in connection with the use and working of such material sources outside the Right-of-Way boundaries shall have been provided for by the Contractor in the rates entered against the appropriate items in the Bills of Quantities

The quantity of rock estimated as being required for crushing for aggregate has been separated from the other quantities for earthworks in the Bills of Quantities. Excavation of rock for crushing for use as aggregates shall be measured under Item 207.003 of the Bills of Quantities, and shall include for haulage to the crushing plant. The measurement for the incorporation of such aggregate material into the Works shall be made under the other items of the Bills of Quantities relating to the various components of the Works for which such aggregate is utilized, and the rates which shall have been entered by the Contractor against those items will be deemed to include for all necessary operations (including, but not limited to, crushing and haulage) required to produce the said aggregate in its final location in the Works.

Bill of Quantities Item 211.002 "Rock borrow excavation" is a provisional item. Its intention is to provide a contingency allowance for the Engineer to utilize or not for the excavation of rock material from outside the Right-of-Way boundaries, as he shall deem appropriate.

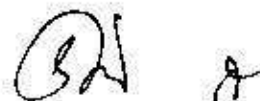

**SECTION 212  
EXCAVATION FOR STRUCTURES**

**EXCAVATION AND BACK FILLING FOR STRUCTURES**

**212.1 - DESCRIPTION:**

This work shall consist of the excavation and backfill (or disposal) of all materials required to be removed for the construction of retaining walls, culverts, catch basins, drop inlets, manholes, bridge foundations, and other structures for which excavation is not otherwise provided. The removal of all old structures, including abutments, piers and wingwalls, unless otherwise specified or directed; in accordance with these Specifications and in reasonably close conformity with the lines, grades and typical cross sections shown on the Drawings or established by the Engineer. It shall include pumping, draining, shoring, sheeting, sheet piling and constructing cribs and cofferdams if necessary.

**212.2 - MATERIALS:**

Select material for backfilling shall be crushed stone, gravel, slag, or any combination thereof meeting the requirements of Section 703. The grading shall be such that 100 percent of the material passes the 50 mm sieve and 0 to 5 percent passes the No.16 sieve. Any of the standard coarse aggregate sizes from AASHTO No. 4 through AASHTO No. 8 as shown in 703.4 will be acceptable.

Quality control of select material for backfilling is the responsibility of the Contractor.

The material shall be tested according to applicable methods specified in Section 716. The sampling frequency for gradation is specified in AASHTO, T180. Acceptance for gradation will be on the basis of the Contractor's written certification that all such materials used for this item conforms to the specified requirements. The certification is to include the test results.

Engineering fabric shall be Fabric for Subsurface Drainage or Separation meeting 715.11.

**CONSTRUCTION METHODS**

**212.3 - GENERAL:**

The foundation pits shall be excavated according to the outlines of footings as shown on the Drawings and shall be of sufficient size to permit the placing of the full width and length of the footing. The Engineer may order, in writing, such changes in dimensions or footing elevations as may be necessary to secure a satisfactory foundation.

Structural excavation for pipe culverts and underdrains shall be accomplished in accordance with the sections covering pipe culverts and underdrains.

All foundation excavation adjacent to the tracks of any railroad shall be shored, braced and supported as required by the Sri Lanka Government Railway or the Engineer, and the Contractor will be held responsible for securing such information and complying. Drawings for this shoring, bracing, and supporting shall be submitted to and shall meet with the approval of the Chief Engineer of the Sri Lanka Government Railway before starting excavation. Bracing, shoring, and supporting excavation at structures other than railroad tracks shall meet with the approval of the Engineer.





**212.4 - DISPOSAL OF MATERIAL:**

The excavated material, unless otherwise directed by the Engineer, shall be utilized for backfill or embankments. Surplus material and unsuitable material shall be disposed of in such a manner that the efficiency or appearance of the structure shall not be impaired, nor the stream muddied or obstructed.

**212.5 - COFFERDAMS:**

The term cofferdam designates any temporary barrier system that provides a dry, watertight as practicable, area for excavation, inspection or placing concrete in construction of structures specified in this specification.

Subject to other requirements in these Specifications, a cofferdam may be constructed of materials including sheet piling, wood, sand bags, earth embankment, etc. or a combination of any of these. The sheet piles used for a cofferdam will be included in the rate of cofferdam. Sheet piles used in other areas will not be measured separately and paid for.

Cofferdams shall, in general, be carried well below the bottom of the footings and shall be well braced and as watertight as practicable. The interior dimensions of cofferdams shall be sufficient to give adequate clearance for the construction of forms and to permit pumping from outside of the forms. When sandy or porous material is encountered in the foundation, which renders it impracticable to dewater the excavation before placing masonry, the bottom may be sealed with concrete placed by the tremie method, after which the remainder of the work shall be carried on in the dry.

No bracing of any kind shall be left in cofferdams in such a way as to extend in to the substructure masonry without the written permission of the Engineer.

The Contractor upon completion of the substructure shall remove cofferdams.

**Shoring**

Shoring shall be executed as required to support sides of excavation.

**Cribs**

Concrete or steel cribs shall be constructed if required according to Sections 634 and 635.

**212.6 - PUMPING:**

Pumping from the interior of any foundation enclosure shall be executed in such a manner as to preclude the possibility of the passage of water through fresh concrete. No pumping will be permitted during the placing of concrete, or for a period of at least 24 hours, unless it is executed with a suitable pump separated from the concrete by a watertight wall.

**212.7 - INSPECTION:**

After an excavation is completed, the Contractor shall notify the Engineer, and no footing, pipe, or other structure shall be placed until the Engineer has approved the depth of excavation, the character of foundation material encountered, and has obtained the necessary foundation measurements.





**212.8 - PREPARATION OF FOUNDATIONS:**

Rock or other hard foundation material shall be free from all loose material, cleaned and cut to a firm surface, stepped or serrated as directed by the Engineer. All seams shall be cleaned and filled with concrete, mortar, or grout. Excavation in rock shall be made to the neat lines of the footing as nearly as practicable and the concrete placed against the rock without forming.

When masonry is to rest on an excavated surface other than rock, special care shall be taken not to disturb the bearing surface, and the final removal of foundation material shall not be made until just before masonry is to be placed.

**212.9 - DRAINAGE:**

Adequate drainage for the backs of retaining walls, abutments and wing walls shall be provided by outlet tile or pipe drains extending through the walls at the ground line or as indicated on the Drawings. In case the outlet end of these drains is below the ground line or would be covered by fill material, the drains shall connect to pipe outlets or be extended to the toe of the slope of the fill.

When drain pipes are not called for or indicated on the Drawings for these drains, the drains shall be constructed to a minimum sectional area of 600mm by 600mm and shall consist of sand, crushed stone, or gravel. Excavation and backfilling shall conform to the requirements of this Specification.

When underdrains with pipe are shown or indicated on the Drawings and there are bid items for the same, they shall conform to the applicable requirements of Section 606.

The back of retaining walls, abutments and wing walls shall have porous drains, 300mm thick or as shown on the Drawings, placed on the back side of the walls and abutments for the entire length and height of the same, beginning at the elevation of the outlet drains.

**212.10 - BACKFILLING:**

Backfill material shall be suitable unclassified material, controlled low strength material or select backfill material. Unclassified material shall be free from particles larger than 75mm, wood, or other extraneous material.

Unless otherwise specified in the Drawings, any of the types of controlled low strength material may be used and shall be an alternative to unclassified material at the contractor's option. Select backfill material shall be in accordance with Section 212.

All spaces excavated and not occupied by abutments, piers, or other structures shall be backfilled to the surface of the surrounding ground. All backfill, except controlled low strength material, shall be thoroughly compacted by rolling or tamping as prescribed below and the top surface neatly graded. Unclassified material and select backfill material behind and around abutments, wingwalls, piers, bents, pedestals and all other structures, including those inaccessible to a roller, shall be compacted in layers not to exceed 100mm after compaction.

The quality control and acceptance for compaction of unclassified material shall be in accordance with applicable sections of 207 and 716. Five density tests shall be performed for quality control. The target percentage of dry density shall be 95 percent.

Handwritten signature or initials in black ink, possibly reading 'BN' followed by a flourish.

Special precautions shall be taken to prevent any wedging action against the masonry and the slope bounding the excavation for abutments and walls. Stepping or serration to destroy wedge action shall prevent such condition. Jetting of fill behind retaining walls, abutments, and wing walls will not be permitted. Backfill over and around abutments, culverts, arches, and columns shall be brought up uniformly to avoid bending or distortion stresses in the structures, shall be made as soon as practicable after forms are removed, and shall be sloped to drain. The 100 mm layer requirement and compaction for backfill in water will be waived. The testing of backfill compaction, at piers or other structures, which will not become part of an embankment or highway pavement or shoulder area, will be waived.

Select backfill material shall be placed behind abutments, wing walls, retaining walls, and box culverts to the dimensions shown on the Drawings. The material shall be placed in horizontal layers not to exceed 100 mm compacted.

The quality control testing and acceptance for the select backfill material shall be in accordance with applicable sections of 207 and 716.

A lot shall normally consist of the quantity of backfill material required to fill behind and around abutments, wing walls, piers, bents, pedestals and all other structures as approved by the Engineer.

The select backfill materials shall be tested according to AASHTO- T-310 Five density tests shall be performed for quality control. The target percentage of dry density shall be 95 percent of modified density.

In all areas where select backfill will contact unclassified material, engineering fabric shall be placed in accordance with the last paragraph of 207.9.

#### **212.11 - METHOD OF MEASUREMENT:**

The quantity of work executed for Pay Items will be measured in cubic metres, calculated from dimensions shown on drawings and/or as directed by the Engineer.

All excavation performed under this section will be classified as "Structural Excavation", for the type of structure being excavated, under the heading of "Unclassified", "Unsuitable", or "Rock" excavation. Any boulders greater than 0.5 cubic metres in volume encountered during excavation works will be considered as "Rock Excavation" and paid for as such. The cost of bracing, shoring, and supporting excavation adjacent to railroad tracks and other structures shall be included in the unit price bid for "Structure Excavation", "Wet Excavation", or "Rock Excavation".

Structural excavation for old structures requiring removal will be deemed to included for in the rate or price for removal. No separate payment will be made excavation.

Excavation for the drains specified in 212.9 will be paid as "Structural Excavation", and the cost of backfilling drains with crushed stone or gravel shall be included in the appropriate backfilling pay items.

Clearing of right-of-way within the construction limits of piers, abutments, retaining walls, etc., and backfilling to the level of the original ground will be included in unit prices bid for "Clearing" or "Clearing and Grubbing" works.



If backfill above original ground is required, material for the backfill will be measured and paid from the ground, not the reduced level after clearance.

Items for excavation shall be deemed to include upholding sides of excavation additional excavation to provide working space and removal of dead services.

Items for filling shall be deemed to include compaction.

The measurement and payment for engineering fabric will be measured separately in square metres complete in place and accepted excluding laps.

Shoring shall not be measured and paid separately, but included in unit rates.

Items for "Cofferdams", if required, will not be measured and paid for separately but deemed to be temporary works included for in the structural excavations for the type of structure requiring the cofferdam.

With reference to the second paragraph of Technical Specifications Sub-Section 212.11, "Structure Excavation" shall be measured under the appropriate items listed in Bill of Quantities Page 15 of 44. These items are also listed in the tabulation of "Pay Items" under Sub-Section 212.13 of the Technical Specifications

Notwithstanding the final sentence in the second paragraph of Technical Specifications Sub-Section 212.11, "The cost of ..... or "Rock Excavation", the cost of bracing, shoring, and supporting of all excavation carried out for structures shall be included in the unit prices for excavation in the Bill of Quantities.

The bidders' attention is drawn to the reference to Section 212 in Sub-Section 604.12 of the Technical Specifications, Page 20 of 118, three lines from the bottom of the page. Excavation for drainage structures (including culvert pipes) shall be measured under Bill of Quantities Items 212.001, 212.003, and 212.005. Backfill for same shall be measured under Bill of Quantities Item 212.007.

**212.12 - BASIS OF PAYMENT:**

The quantities, measured as provided above for applicable pay items, will be paid for at the contract unit rates or prices bid for these items. These prices and payments shall be full compensation for furnishing all materials and doing all the work prescribed in a workmanlike and acceptable manner, including all labour, tools, equipment, supplies, haulage and incidentals necessary to complete the work, also including cost of cofferdams and sheet piling and their removal.



**212.13 - PAY ITEMS:**

ITEM	DESCRIPTION	UNIT
212.001	Unclassified excavation for drainage structures	Cubic metres
212.002	Unclassified excavation for minor structures (Retaining walls Drainage Box culvert)	Cubic metres
212.003	Unsuitable excavation for drainage structures	Cubic metres
212.004	Unsuitable excavation for minor structures (Retaining walls Drainage Box culvert)	Cubic metres
212.005	Rock excavation for drainage structures (Provisional)	Cubic metres
212.006	Rock excavation for minor structures (Retaining walls) (Provisional)	Cubic metres
212.007	Structural backfill for drainage structures (using 0-50mm aggregated material)	Cubic metres
212.008	Structural backfill for minor structure (using 0-50 mm aggregate material)	Cubic metres
212.009	Geotextile material Class B	Square metres
212.010	Unclassified excavation for drainage canal	Cubic metres
212.011	Unsuitable excavation for drainage canal	Cubic metres

Payment items for excavation, backfill and bedding for various concrete pipe culverts and drop inlets shall be made separately under Bill of Quantities Items 212.001, 212.007, and 604.014 respectively.

With reference to the "Quantities" referred to in Drawing No. LW0001 of the bidding documents: 'Gabions' shall be measured under Item 218.003 of the Bills of Quantities; 'Facing Panels' shall be measured under Item 564.001 of the Bills of Quantities; and 'Soil Mass' shall be measured under Item 564.002 of the Bills of Quantities.

'Geogrid reinforcement' for foundations to retaining walls shall be measured under Item 212.009 of the Bills of Quantities.

'Geogrid' and 'Filter Cloth' shall comply with Sub-Section 715.11 of the Technical Specifications.

Geogrid for drainage wicks as shown.

Notwithstanding the 1 m Special Rock Fill thickness dimension shown in Detail B of Drawing TX0009, the actual thickness of the said layer shall be determined by the Engineer for each location at which drainage wicks shall be installed.

The Method of Measurement of FDB trench shall be, as stated in Sub-Section 606.9.2 of the Technical Specifications, inclusive of the perforated pipe and shall be measured under Item 606.001 of the Bill of Quantities and Dayworks.

Notwithstanding what is stated in Sub-Section 606.9 – Method of Measurement, of the Technical Specification, all unit rates for underdrains shall be inclusive of pipes and plastic drainage core.

The types of underdrains are shown in Drawing. Excavation for underdrains shall be measured separately in accordance with Section 212 of the Technical Specifications and paid under the relevant items in Sub-Section 212.3.

The Outlet Pipe End Treatment shall be as shown in Drawings and the construction of wingwalls are not envisaged.

The payment for Engineering Fabric for Free Draining Base Trench shall be in accordance with Item No. 212.028 of the Bill of Quantities and Dayworks.

The locations, type and extent of underdrains shall be as directed by the Engineer.

**212.13 – PAY ITEMS (Contd.)**

ITEM	DESCRIPTION	UNIT
212.012	Unclassified excavation	Cubic metres
212.013	Unsuitable excavation	Cubic metres
212.014	Rock excavation	Cubic metres
212.015	Not used	Cubic metres
212.016	Not used	Cubic metres
212.017	Structural backfill for structures (using 0-50 mm aggregate material)	Cubic metres
212.018	Structural backfill for	Cubic metres
212.019	Unclassified excavation for metal underpasses	Cubic metres
212.020	Unsuitable excavation for metal underpasses	Cubic metres
212.021	Rock excavation for metal underpasses	Cubic metres
212.022	Structural backfill for metal underpasses	Cubic metres
212.023	Geotextile material Class B for metal underpasses	Square metres
212.024	Unclassified excavation for concrete underpasses	Cubic metres
212.025	Unsuitable excavation for concrete underpasses	Cubic metres
212.026	Rock excavation for concrete underpasses	Cubic metres
212.027	Structural backfill for concrete underpasses (using 0-50mm aggregate)	Cubic metres
212.028	Geotextile material Class B for concrete underpasses using 0-50 mm aggregate material)	Square metres

**SECTIONS 213 - 216: Not Used**



**SECTION 217  
SPECIAL ROCK FILL**

**217.1 - DESCRIPTION:**

This work shall consist of furnishing and placing at the foot of embankments, inside or outside the neat line, where called for on the Drawings or as directed by the Engineer, durable rock in accordance with the Specifications and in reasonably close conformity to the lines, grades, dimension and sections shown on the Drawings.

**217.2 - MATERIALS:**

The rock for special rock fill shall meet the requirements specified in 704.5. Geogrid Filter cloths shall meet the requirements specified in 715.11. The material used for Special Rock Fill shall not be limited to "limestone or sandstone". Rock of alternative geological origin will be acceptable provided it complies with the physical characteristics prescribed in the Specifications for Special Rock Fill.

The material used for Special Rock Fill shall not be limited to "limestone or sandstone". Rock of alternative geological origin will be acceptable provided it complies with the physical characteristics prescribed in the Specifications for Special Rock Fill.

Geomaterials shall meet the requirements specified in 715.11

**CONSTRUCTION METHODS**

**217.3 - GENERAL:**

Where possible, the material shall be handled as ordinary rock embankment as prescribed in 207.7.3; however, if the location for the special rock fill is not accessible to ordinary placing, the material may be placed by other methods.

Foundation trenches and other necessary excavations shall be excavated by the Contractor, in accordance with the applicable provision of Section 212, and approved by the Engineer before the placing of the special rock fill is begun.

Unless otherwise shown on the Drawings or directed by the Engineer, the rock fill shall extend approximately 600 mm below the bed of the stream.

The rock fill shall be of specified materials and furnished and compacted to lines and levels given in the Drawings or as instructed by the Engineer. Geogrid filter material shall be provided accordance with the Section 606.

Drainage wicks are provided accordance with Section 606, Drawings, and this specification. The Engineer shall determine the depth of the drainage wicks and the spacing, unless otherwise given in Drawings.

**217.4 - METHOD OF MEASUREMENT:**

The quantity of work executed will be measured in cubic metres of "Special Rock Fill", complete in place and accepted, determined by the average end area method.

Trimming and preparation shall be deemed to be included with fill items.

⑧ 217

The Geogrid materials are measured in square metres complete in place and accepted as per Section 207.

The Drainage wicks shall be measured in Numbers complete in place and accepted according to Section 606.

**217.5 - BASIS OF PAYMENT:**

The quantity, determined as provided above, will be paid for at the contract unit price bid for following items, which price and payment shall be full compensation for furnishing all the material and doing all the work prescribed in a workmanlike and acceptable manner, including all labour, tools, equipment, haulage and incidentals necessary to complete the work.

**217.6 - PAY ITEM:**

ITEM	DESCRIPTION	UNIT
217.001	Special rock fill 10mm < 20mm (provisional)	Cubic metre
217.002	Special rock fill 50mm < 150mm (provisional)	Cubic metre
217.003	Fine aggregate filter (provisional)	Cubic metre
217.004	Shot rock	Cubic metre

925 2

**SECTION 218  
SLOPE AND FOUNDATION PROTECTION**

**218.1 - DESCRIPTION:**

This work shall consist of the construction of revetments and drains of stone or concrete, with or without engineering fabric, to prevent erosion of slopes or banks, or to protect foundations, at places indicated on the Drawings or where designated by the Engineer, all in accordance with these Specifications and in reasonable close conformity with the lines, grades, dimension, and cross sections shown on the Drawings. The work shall also consist of the installation of soil nails, rock anchors and perforated pipe weep-holes all as directed by the Engineer.

**218.2 - MATERIALS:**

Materials shall meet the requirements specified in the following Sub-Sections of Division 700:

**MATERIALS SUBSECTIONS:**

Cement for Grout:	701.1 or 701.3
Fine aggregate for Grout:	702.1.1 through 702.1.5 and 702.6, or 702.2
Stone for Stone Pitching:	704.2
Stone for Gabions:	704.3
Gabion:	715.23
Reinforcement:	709.3, 709.4
Shot Rock: 704.8	
Engineering Fabric for Erosion Control:	715.11

The stone for crushed rock slope protection shall meet the requirements of 704.6, Class 7, except 704.6.3. Acceptance will be based on the results of site testing at crusher plant. The certification for Class 7 material shall include a description of the crushing operation indicating the screens used.

An alternative to this gradation shall be AASHTO size No.1 certified test data from site testing the producer showing the AASHTO No.1 material meets the gradation requirements of 703.4, when tested from samples obtained at a minimum frequency of one sample per half day of stockpiling, and does not exceed a weighted loss of 30 percent when subjected to five cycles of the Sodium Sulphate Soundness Test, ASTM C 88, will be acceptable.

Stone for foundation protection shall conform to the requirements of stone pitching stone, except for size and shape.

**CONSTRUCTION METHODS**

**218.3 - SLOPE PROTECTION:**

**218.3.1 - General:**

The slopes to be revetted shall reasonably conform to the lines, grades, dimensions, and cross sections as shown on the Drawings, unless otherwise directed by the Engineer.

The placing of stone pitching or grouted stone pitching shall start in a trench, the invert of which is parallel to and 600 mm below the toe of the slope, and the trench shall be 600 mm in width. The construction shall progress from the invert of the trench up the slope to conform to the

requirements specified. Slope protection with crushed rock, concrete slabs, or precast concrete blocks shall start at a concrete bottom sill, shall be included within side sills, and shall progress upward to the berm in front of the abutment. The design and dimensions of the sills shall be as shown on the Drawings. The area of the sills shall be considered a part of the area of the slope protection. The concrete sills may be precast or cast-in-place and shall be placed in a trench excavated to receive them. Concrete used in the sills shall meet the requirements specified in 218.3.6.2.

Construction equipment shall not operate directly on engineering fabric. The fabric shall be protected from detrimental contamination by surface runoff. Any fabric so contaminated shall be removed and replaced with uncontaminated fabric.

Weep holes shall be provided as directed by the Engineer when grouted stone pitching, concrete slab, or concrete block slope protection is specified.

**218.3.2 - Stone pitching:**

Stone pitching shall be composed of stones having the dimensions specified, each stone being firmly bedded on the slope in such a manner that it abuts against other stones to form a layer, the interstices of which are filled with suitably sized spalls. The dimensions of each stone in a plane parallel to the plane of the slope shall be not less than 75mm by 300mm unless otherwise specified; the longer dimension shall be placed horizontally. The surface of each stone shall not vary more than 75mm from the specified surface plane. Abutting stones shall have depths not different by more than 40 mm. The average depth of the stone placed in the stone pitching shall be not less than the specified depth of the stone pitching. The first row of stone shall be firmly bedded on the invert of the trench to form a firm foundation, and the construction shall progress up the slope by fitting additional and abutting stones with well broken joints and in such a manner that the most compact mass of stone pitching is developed.

**218.3.3 - Grouted Stone pitching:**

Grouted stone pitching shall be as defined in 218.3.2 with the interstices filled with spalls and grouted with cement grout. The grout filler shall be composed of a mixture of one part Portland cement and three parts sand, mixed with water to produce a workable consistency. The amount of water shall be that designated by the Engineer. The stone shall be thoroughly wet immediately before grout is applied. As soon as the grout is deposited on the surface, it shall be thoroughly worked into the joints. The stones shall then be brushed so that their top surfaces are exposed.

Grouted stone pitching shall be cured in accordance with any of the methods specified in 501.15, with a blanket of earth kept wet for 72 hours, or by sprinkling with a fine spray of water every two hours during the daylight hours for a period of three days.

**218.3.4 - Gabions and Reno Mattresses:**

Gabions and Reno mattresses, consisting of galvanized wire mesh baskets filled with rocks, shall conform to these Specifications and the dimensions shown on the Drawings. Assembling of the gabion and mattress units and their filling with rock shall be carried out as directed by the Engineer. The visible faces of the baskets shall be hand placed to insure an attractive appearance, and the core of the baskets may be filled by mechanical equipment. Galvanised Box Gabions with diaphragms shall be used for the construction of gabion structures.

Galvanised Box Gabions with Diaphragms shall be used for the construction of gabion structures for the Contract.

**218.3.5 - Crushed Rock Slope Protection:**

The thickness of crushed rock slope protection shall be as indicated on the Drawings. The rock shall be raked in place to obtain a reasonably smooth and continuous surface conforming to the thickness and slope lines indicated on the Drawings.

**218.3.6 - Concrete Slope Protection:**

**218.3.6.1 - General:**

Concrete slope protection may be by cast-in-place concrete slab, precast concrete blocks or dry concrete filled hessian sacks; only one method shall be used at any one bridge.

**218.3.6.2 - Cast-in-Place Concrete Slab:**

Concrete slabs shall be not less than 150 mm thick, be reinforced with Type B Fabric, and shall conform to the applicable provisions of Section 501, unless otherwise indicated. Transit mix concrete will be permitted. A wood float finish will be acceptable. Construction joints shall be provided at intervals of 3 metres in both directions. Concrete Class 35/20, meeting the requirements of Section 601 may be used in lieu of the concrete provided above.

**218.3.6.3 - Precast Concrete Blocks:**

Precast concrete blocks shall conform to the applicable provisions of Section 601 and shall be made of Class 45/20 concrete, reinforced with Type B fabric. The blocks shall be 1000mm by 500mm by 100 mm thick. The longer dimension shall be placed on a horizontal plane. The blocks shall be firmly embedded against the slope and against adjoining blocks, with the ends in contact. The finished surface shall present an even, tight surface, reasonably true to line, grade, and section.

**218.3.6.4 - Dry Concrete Filled Hessian Sacks**

This work consists of placing small hessian porous sacks (sand bags) filled with dry mixed concrete and placing on slopes etc. as shown on the Drawings and/or instructed by the Engineer.

**218.3.7- Engineering Fabric:**

**218.3.7.1 - Fabric Placement:**

The area in which the fabric is to be installed shall be prepared in a relatively smooth state, free of sharp protrusions, depressions and debris. The machine direction of the fabric shall generally be placed parallel with the direction of major water flow, i.e., parallel to the stream or as authorized by the Engineer. The fabric shall be placed in a relatively loose and unstretched condition such that the fabric and underlying material deforms slightly under stone pitching weight when placed. Fastener pins shall be placed to prevent displacement of the fabric.

The fabric shall be field sewn as described in 715.11.3 or overlapped. When the overlapping technique is used, an overlap of 900 mm shall be maintained so the upgrade fabric shall always be lapped over the downgrade fabric.





### **218.3.7.2 - Cover Material Placement:**

Extreme care shall be exercised in placing cover material over the fabric, especially when stone pitching is used. Under no circumstances shall heavy angular stone, such as stone pitching, be dropped on the fabric from more than 300 mm in height. A cushioning layer of sand or gravel may be placed between the fabric and stone pitching, providing this material does not inhibit free drainage of the slope.

All cover material shall be placed from down slope to upslope in such a manner as to prevent slippage of the cover material off the fabric.

### **218.3.8 – Soil Nailing:**

The basic concept of soil nailing is to reinforce and strengthen the existing ground by relatively closely spaced inclusions, steel bars, also referred to as "nails", into a slope or excavation as it proceeds top-down. This process creates a section that is internally stable and able to retain the ground mass behind. The nails are passive in nature and develop their reinforcing action through nail-ground interactions as the ground deforms during and immediately following the construction. The effect of soil nail is to improve stability of the potentially sliding soil mass by (a) increasing the normal force and hence the shear resistance along slip surface in frictional soils; and (b) reducing the driving force along the potential slip surface for all soils.

The steel nail bars are typically 16 to 25 mm in diameter, with yield strength in the range from 420 to 480 N/mm<sup>2</sup>, and are typically installed into drill holes having diameters in the range of 50 mm to 100 mm and at spacing between 1.5 and 2.5 meters. The nail lengths depend on the wall geometry, nail spacing, soil, groundwater and loading conditions. Nail declinations are generally on the order of 15 degrees below horizontal to facilitate grouting. Soil nails typically consist of steel reinforcement inclusions and may be categorized on the basis of their method of installation and degree of corrosion protection. For conventional drill and grout nail installations, the nail grout consists typically of a neat cement grout with a water cement ratio of about 0.4 to 0.5. Sand-cement grout is also used in conjunction with large nail holes for economic reasons.

#### **218.3.8.1 - Construction of Soil Nail Walls**

The typical sequence to construct a soil nail wall using the drill and grout method of nail installation is as follows:

##### **1. Excavate Initial Cut**

The initial cut is excavated to a depth slightly below the first row of nails, typically about 2 meters depending on the ability of the soil to stand unsupported during construction. Where face stability is problematical for these periods of time, a stabilizing berm can be left in place until the nail has been installed and final trimming then takes place just prior to application of the facing.

##### **2. Drill Hole for Nail**

Nail holes are drilled at predetermined locations to a specified length and inclination using a drilling method appropriate for the ground conditions. Drilling methods include both uncased methods for more competent materials (rotary or rotary percussive methods using air flush, and dry auger methods) and cased methods for less stable ground (single tube and duplex rotary methods with air or water flush, and hollow stem auger methods).

BS J

### **3. Install and Grout Nail**

Plastic centralizers are commonly used to center the nail in the drill hole. The nails are inserted into the hole and the drill hole is filled with cement grout to bond the nail bar to the surrounding soil. Grouting takes place under gravity from the bottom of the hole upwards, either through a tremie pipe for open-hole installation methods or through the drill string (or hollow stem) or tremie pipe for cased installation methods.

The soil nails need to be protected against corrosion. Grouted soil nails will have the protection of the grout cover for corrosion protection. In addition, permanent nails are protected against corrosion by one of the following methods as needed: a) Hot Dip Galvanizing, (b) Epoxy Coating, and (c) Encapsulation

### **4. Install Bearing Plates and Grid Facing**

Typically trench excavations are made for recessed beams. Reinforcements and Plates are installed at nail heads. The recessed beam (grid) facing is constructed by shotcrete to connect the nails.

### **5. Repeat Process to Final Grade**

The sequence of excavate, install nail, and place construction facing is repeated until the final wall grade is achieved. The shotcrete facing may be placed at each lift prior to nail hole drilling and nail installation, particularly in situations where face stability is a concern. The sites where face stability is not a problem, the construction is performed at once without using stages/lifts as it is the more economical form of construction.

## **218.3.9 – Specification for Rock Joint Sealing**

### **218.3.9.1 General**

The objective of Rock joint Sealing is to arrest the water seeping through weaker joints in rock and weathered rock on cut slope.

### **218.3.9.2 Materials**

Portland cement type I or I-II cements conforming to ASTM C 150 or C 595. Other cementitious materials, such as blended hydraulic cements should meet ASTM C1157.

Admixture, for cementitious grouts with enhanced properties of water proofing adhesion and positive expansion. Cebex 100 (Formerly Conbex 100) is recommended and any other equivalent should be submitted to engineer for his review and approval.

Water used in mixing should be clean and free from other harmful or deleterious substances like oil, salt, acid, alkali, organic matter or other.

### **218.3.9.3 Mixing**

Mixer with slow speed drill fitted with a high shear paddle shall be used for mixing. Mixing shall be done continuously for 5 minutes, making sure that a smooth even consistency is obtained.

### **218.3.9.3 Placing**

The Contractor shall thoroughly clean the joint area by scrapping all weaker layers using hand tools and shall be washed with clean water to remove dusts. The sealing agent shall be poured afterward to the joint so that joint is properly covered with the sealant. Sealing shall be consistence throughout and shall not have any voids.

### **218.4 - FOUNDATION PROTECTION:**

The area around piers, abutments or other foundations shall be excavated to a depth and width indicated on the Drawings, or as otherwise directed.

Stone for foundation protection shall be largely equi-dimensional, angular, and generally ranging in size between 300 millimetres and one metre. The stone need not be placed, but may be dumped from trucks or bulldozed in place. The stone shall be placed where indicated on the Drawings or as directed by the Engineer.

### **218.5 - METHOD OF MEASUREMENT:**

The quantity of work executed under Slope Protection will be measured in cubic metres of "Gabions", "Reno mattresses", "Stone pitching" and "Grouted stone pitching". "Crushed rock slope protection" and "Fabric for erosion control", excluding overlaps, will be measured in square metres.

The quantity of work executed under rock anchors and perforated weep-hole pipes will be measured in metres.

The quantity of work executed under soil nailing and shotcreting will be measured in square metres all as directed and accepted by the Engineer.

### **218.6 - BASIS OF PAYMENT:**

The quantities, determined as provided above, will be paid for at the contract unit prices bid for these pay items. These prices and payments shall be full compensation for excavating, drilling and preparing the embankment or slope, footing and sill trench; furnishing all the materials, including steel reinforcement and anchors; and doing all the work prescribed in a workmanlike and acceptable manner, including all labour, tools, equipment, supplies, and incidentals necessary to complete the work.

Any items of slope protection work referred to in the Technical Specifications but which are not mentioned in the Bills of Quantities are not required for the Works.

The measurement of stone pitching (plain ungrouted) shall be by square metre for the nominal thickness of 0.5 metre measured at 90° to the sideslope surface.

The measurement of grouted stone pitching shall be by square metre for the nominal thickness of 0.35 metre measured at 90° to the sideslope surface.

## 218.7 - PAY ITEMS:

ITEM	DESCRIPTION	UNIT
218.001	Stone pitching (Provisional)	Square metre
218.002	Grouted stone pitching	Square metre
218.003	Gabion	Cubic metre
218.004	Reno mattress	Cubic metre
218.005	Dry concrete filled sacks (Provisional)	Cubic metre
218.006	Random rubble masonry	Cubic metre
218.007	Precast concrete facing panel	Square metre
218.008	Anchored earth fill	Cubic metre
218.009	Granular backfill	Cubic metre
218.010	Surface ceiling in G 15(20) concrete, 150mm thick	Square metre
218.011	Grade 20(20) concrete for berm drains, drain, cascade etc(PS)	Cubic metre
218.012	Swan formwork(PS)	Square metre
218.012a	Wrought formwork(PS)	Square metre
218.013	Reinforcing steel bar(PS)	kg
218.014	L Shaped 16 mm galvanized double tie bar with non-shrink grout in 1.5 m length (hole = 150 mm Ø)	Number
218.015	16 mm Galvanized rebar with end lighting arrangement and non-shrink grout in 1.5 m length ( hole = 100 mm dia )	metre
218.016	wheep hole with filtering arrangement	Number
218.017	Sealing with non-shrink and water proofing cementation mix	Litre
218.018	Filling with 20/20 concrete	Cubic metre
218.019	Drilling and installing 25 mm L shaped hot dip galvanized dowels (max. 3 m depth)	metre
218.020	Fixing of relief drains on cavities where necessary (1 m length)	Number
218.021	Filling and compacting using lateric soil for cavities less than 0.5 m deep	Square metre
218.022	Filling with random rubble masonry for cavities larger than 0.5 m deep	Cubic metre
218.023	Installing dowels on soil	metre
218.024	Installing dowels on rock	metre
218.025	Layer of porus fabric wrapped in filter fabric drain mat	Square metre
218.026	Impermeable fabric	Square metre
218.027	Fixing of 50 mm dia PVC pipe (length 0.5 m) including necessary drilling weathered rock	Number
218.028	Fixing of relief drain on rock surface	Number

218.029	High yield deformed 25 mm L shaped hot dip galvanized dowels (-1 m) with cementitious non-shrink grout (25 N/mm <sup>2</sup> at 7 days) including drilling and installation on weathered rock	Number
218.030	High yield deformed 25 mm L shaped hot dip galvanized dowels (-0.6 m) with cementitious non-shrink grout (25 N/mm <sup>2</sup> at 7 days) including drilling and installation on weathered rock	Number
218.031	Concrete/shotcrete (dry batch) including supplying and installation	Square metre
218.032	Wiremesh including installation 100x100x6mm	Square metre
218.033	Wiremesh including installation 50x50x3.15mm	Square metre
218.034	Slope protection using Soil Nailing method	Square metre

**SECTION 219  
CONTROLLED LOW-STRENGTH MATERIAL**

*BLS*



**SECTION 220  
TEMPORARY EROSION CONTROL**

**220.01 – DESCRIPTION:**

This work consist of constructing, installing, maintaining, and removing when required, erosion control measures during the life of the construction to prevent or minimize erosion, sedimentation, and pollution of any rivers, state waters and/or wetlands etc.

The Contractors shall coordinate the construction of temporary erosion control measures with the construction of permanent erosion control measures to assure economical, effective, and continuous erosion control throughout the construction period.

**220.02 – MATERIALS**

The term "geotextile" covers all the synthetic membranes referred to as:

- "geogrid",
- "engineering fabric", and
- "filter cloth".

"Geogrid" is an open grid material, in various configurations, used for structural reinforcement.

"Engineering fabrics" and "filter cloths" are primarily used for creating a filter interface between different types and/or gradations of soil.

The material for erosion control measures shall conform to the following:

**Erosion Bales:** Material for erosion bales shall consist of certified weed free forage. Each certified weed free erosion bale should be identified by one of the following:

One of the ties binding the bales shall consist of blue and orange twine, or

One of the ties binding the bale shall consist of specially produced shiny galvanized wire.

Erosion bales shall be inspected for and certified as weed free, based on designated Noxious Weed and Undesirable Plant Lists found in Sri Lanka.

The Contractor shall not unload certified weed free erosion bales or remove their identifying twine, wire or tags until the Engineer has inspected and accepted them.

Bales shall be approximately 0.14m<sup>3</sup> of material and weight not less than 16 kg.

**Silt fence:** Silt fence posts shall be metal or wood with a minimum length of 1m. Metal posts shall be "studded tee" or "U" type with minimum weight of 1.98 kg/m. Wood posts shall have a minimum diameter or cross section dimension of 50mm. Silt fence geotextile shall conform to 712.08(b).

Geotextile shall be attached to posts with three or more staples per post.

Temporary berms shall be constructed of compacted soil.

Temporary Slope Drains shall consist of fibre mats, plastic sheets, stone, concrete or asphalt gutters, half round pipe, metal or plastic pipe, wood flume, flexible rubber or other materials suitable to carry accumulated water down the slopes.

Brush barriers shall consist of brush, limbs, root mat, vines, soil, rock, or un-merchantable timber.

The erosion control geotextile that covers the barrier shall conform to subsection 712.08 (b).

Check dams shall be constructed of stone, logs, or wooden timbers. Stone shall meet the requirements of Section 506.

Outlet Protection: Outlet protection stone pitching shall conform to Section 506. Erosion control geotextile shall conform to 712.08 (b).

Sediment Trap and Basin: In constructing an excavated sediment trap or basin, excavated soil may be used to construct the dam embankment, provided the soil meets the requirements of Section 203.

### CONSTRUCTION REQUIREMENTS

#### 220.3 - PROJECT REVIEW SCHEDULE, AND EROSION CONTROL SUPERVISOR.

Project Review: The Contractor may submit modifications to the Contract's erosion control measures in a written proposal to the engineer. Such proposed modifications shall be submitted at least 10 working days prior to the beginning of any construction work. The written proposal shall include the following minimum information:

- a) reasons for changing the erosion control measures.
- b) diagrams showing details and locations of all proposed changes.
- c) list of appropriate pay items indicating new and revised quantities.
- d) schedules for accomplishing all erosion and sediment control work.
- e) effects on permits or certifications caused by the proposed changes.

The Engineer will approve or reject the written proposals in writing within two weeks after the submittal. The Engineer may order additional control measures. The Contractor shall be responsible for amendments to permits or certifications required because of the approved changes. Modifications to the erosion control measures shall not be reason for extension of contract time.

At least 10 working days prior to the beginning of any construction work, the Contractor shall submit for approval a schedule for accomplishment of temporary and permanent erosion control work. This schedule shall specify indicate the sequence of clearing and grubbing, earthwork operations, and construction of temporary and permanent erosion control features. The schedule shall include erosion and sediment control, work for all areas within the project boundaries, including but not limited to haul roads, borrow pits, and storage and plant sites. Work shall not be started until the erosion and sediment control schedule has been approved in writing by the Engineer.



Once the work has started, and during the active construction period, the Contractor shall update the schedule for all erosion and sediment control work on a weekly basis, and submit the updated schedule to the Engineer. If during construction the Contractor proposes changes, which would affect the Contract's erosion and sediment control measures, the Contractor shall propose revised erosion and sediment control measures to the Engineer for approval in writing. Revisions shall not be implemented until the Engineer has approved the proposed measures in writing.

Erosion Control Supervisor: the Contractor shall assign to the project an employee to serve in the capacity of the Erosion Control Supervisor (ECS). The ECS shall be a person other than the Superintendent, unless otherwise approved by the Engineer. The ECS shall be experienced in all aspects of construction and have satisfactorily completed an ECS training program. Proof that this requirement has been met shall be submitted to the Engineer at least 10 working days prior to the beginning of any construction work. A list of authorized ECS training programs will be provided by the Engineer upon request by the Contractor.

The ECS's responsibilities shall be as follows:

Ensure compliance with all water quality permits or certifications in effect during the construction work.

Directly supervise the installation, construction, and maintenance of all erosion control measures specified in the Contract and co-ordinate the construction of erosion control measures with all other construction operations.

Direct the implementation of suitable temporary erosion and sediment control features as necessary to correct unforeseen conditions, or emergencies. Direct the dismantling of those features when their purpose has been fulfilled unless the engineer directs that the features be left in place.

Inspect, with the Engineer or designated representative, all erosion control features implemented for the project. The inspections shall take place at least once every 14 days and after each storm event, that causes surface runoff. The report is to be submitted to the Engineer after every inspection, and shall become part of the Project records. The Engineer will supply the appropriate form for this report. The inspections shall be made during the progress of the work, during work suspensions, and until final acceptance of the work. During project suspensions, inspections shall take place at least once every 30 days, or as directed.

Attend all project scheduling meeting.

Upon the Engineer's request, implement necessary actions to reduce anticipated or presently existing water quality or erosion problems resulting from construction activities. The criteria by which the Engineer initiates this action may be based on water quality data derived from monitoring operations or by any anticipated conditions (e.g. Predicted storms), which the Engineer believes could lead to unsuitable water quality situations.

Make available, upon the Engineer's request, all labour, material and equipment judged appropriate by the Engineer to install and maintain suitable erosion and sediment control features.

## **Erosion Control**

### **Unforeseen Conditions:**

The Contractor shall design and implement erosion and sediment control measures for correcting conditions unforeseen during the design of the project, or for emergencies, that develop during construction. The Department's Erosion Control and Storm water Quality Guide" shall be used as a reference document for designing erosion and sediment control measures. Measures and methods proposed by the Contractor shall be reviewed and approved in writing by the Engineer prior to installation.

### **Work outside the Right of Way:**

In areas off the right-of-way that are used by the Contractor and which include, but are not limited to, borrow pits, haul roads, storage and disposal areas, maintenance, batching areas, etc., erosion and sediment control work shall be performed by the Contractor at the Contractor's expense.

### **Construction Implementation:**

The Contractor shall incorporate into the project all erosion and sediment control features as outlined in the accepted schedule.

### **Stabilization:**

Permanent stabilization is defined as the covering of disturbed areas with final seed and mulch as indicated on the Drawings. When required by the Drawings, an erosion control blanket shall be used in combination with the final seed and mulch. Temporary stabilization is defined as the covering of disturbed areas with seed, mulch, mulch with a tack filer, or a combination seed/mulch/tack filer. Other permanent or temporary soil stabilization techniques may be proposed, writing by the Contractor and used upon approval, in writing by the Engineer.

The surface area of erodible earth material exposed at one time by clearing and grubbing, and earth work operations shall not exceed 13.8 ha: 6.9 ha for clearing and grubbing plus 6.9 ha for earthwork operations. The Contractor shall permanently stabilize each 6.9 ha increment of the project immediately upon completion of the grading of that section. Once earthwork has begun on a section, it shall be pursued until completion.

The duration of exposed, uncompleted construction to the elements shall be as short as practicable. Completed areas shall be permanently stabilized within seven days after completion. Disturbed areas where work is temporarily halted shall be temporarily stabilized within seven days after the activity ceased unless work is to be resumed within 30 days after the activity ceased. Payment for temporary stabilization will be made at the contract unit price if the work was interrupted due to no fault or negligence of the Contractor. Payment will not be made for temporary stabilization required by Contractor's negligence, by the lack of proper Contractor scheduling, or for the convenience of the Contractor. Clearing and grubbing operations shall be scheduled and performed so that grading operations and permanent stabilization measures can follow immediately thereafter if the project conditions permit. Otherwise, temporary stabilization measures may be required between successive construction stages. No payment will be made for additional work required because the Contractor has failed to properly coordinate the entire erosion control schedule, thus causing previously seeded areas to be disturbed by operations that could have been performed prior to the seeding. Upon failure of the Contractor to coordinate the permanent stabilization measures with the grading operations in a manner to effectively



control erosion and prevent water pollution, the Engineer will suspend the Contractor's grading operations and withhold monies due to the Contractor on current estimates until such time that all aspects of the work are coordinated in an acceptable manner.

**Maintenance:**

The Contractor shall continuously maintain all erosion and sediment control features to that they function properly during construction and work suspensions until project is accepted.

From the time seeding and mulching work begins until the date the project is declared complete. The Contractor shall keep all seeded areas in good condition at all times. Any damage to seeded areas or to mulch materials shall be promptly repaired as directed.

If the Contractor fails to maintain the erosion and sediment control features in accordance with the Contract, or as directed, the Engineer may at the expiration of a period of 48 hours, after having given the Contractor written notice, proceed to maintain the features as deemed necessary. The cost thereof will be deducted from any compensation due, or which may become due to the Contractor under this contract.

Temporary erosion and sediment control measures shall remain upon completion of the project unless otherwise directed by the Engineer. If removed, the area in which these features were construction shall be returned to a condition similar to that which existed prior to its disturbance. At the completion of the Contract, removed salvageable temporary erosion control items shall become the property of the Contractor.

**Disposal of Sediment:**

Sediment removed during maintenance of erosion control features shall be used in or on embankment provided it meets conditions of Section 203, or it shall be wasted on accordance with Engineers approval.

**Construction of Erosion Control Measures.**

Erosion control measure shall be constructed in accordance with the following.

Seeding, Mulching, Sodding, Soil Retention Blanket, Seeding, mulching, sodding, and soil retention blanket shall be performed in accordance with Sections 212, 213, and 216.

**Erosion Bales:**

The bales shall be placed embedded into the soil and shall be anchored securely to the ground with wood stakes. Stakes shall have a minimum diameter or cross-section dimension of 50 mm. Re-bars shall not be used. Gaps between bales shall be filled with Certified Weed Free mulch to obtain tight joints.

**Silt fence:**

Silt fence shall be installed in locations specified in the Contract prior to any grubbing or grading activity. Sediment shall be removed from behind the silt fence when it accumulates to one half the exposed geotextile height and shall be disposed of in accordance with subsection subsection 207.6.3.



**Temporary Berms:**

Berms shall be constructed to the dimensions shown in the Contract, graded to drain to a designated outlet, and compacted with a minimum of two passes of a rubber tire vehicle, preferably a grader wheel.

**Temporary Diversion:**

Unless otherwise specified in the Contract or directed, the diversion's ridge and channel shall be stabilized within 14 days of its installed prior to any upslope land disturbance.

**Temporary Slope Drains:**

Temporary slope drains shall be installed prior to installation of permanent facilities or growth of adequate ground cover on the slopes. All temporary slope drains shall be securely anchored to the slope. The inlets and outlets of temporary slope drains shall be protected to prevent erosion.

**Brush Barrier.**

The barrier shall be constructed at the time of clearing and shall be covered by an erosion control geotextile.

**Check Dam:**

Logs shall be obtained if possible from clearing operations on the project. Sediment shall be removed from behind the check dam when it has accumulated to one half of the original height of the dam and shall be disposed of in accordance with subsection 207.6.3

**Outlet Protection:**

Geotextile used shall be protected from cutting or tearing. Overlaps between two pieces of geotextile shall be 300 mm minimum.

At excavated drop inlet sediment traps, sediment shall be removed when it has accumulated to one half the design dept of the trap and shall be disposed of in accordance with subsection 207.6.3.

**Storm Drain Inlet Protection:**

Storm drain inlet protection measures shall be constructed in locations and with materials and techniques specified in the Contract. Construction shall be in a manner that will facilitate maintenance, and minimize interference with construction activities.

**Sediment Trap and Basin:**

Sediment traps or basins shall be installed before any land disturbance takes place in the drainage area.

Area under the embankment shall be cleared, grubbed and striped of all vegetation and rot mat. Embankment construction shall conform to Section 203.

Sediment shall be removed from the trap or basin when it has accumulated to one half of the wet storage depth of the trap or basin and shall be disposed of in accordance with subsection 207.6.3.

#### **220.4 - METHOD OF MEASUREMENT**

The temporary works referred to in this Section will not be measured for payment, but considered as incidental works necessary for the execution of the Project.

#### **220.5 - BASIS OF PAYMENT**

Work to furnish, install, maintain, remove, and dispose of erosion and sediment control features specified in the Contract will not be paid for separately but considered to be covered in the overall Contract Price.

In the case of repeated failure on the part of the Contractor in controlling erosion, sedimentation, or water pollution, the Engineer reserves the right to employ outside assistance or to use Department forces to provide the necessary corrective measures. Such incurred direct costs, plus project engineering costs, will be charged to the Contractor's monthly progress estimate.

The requirement for temporary erosion control referred to in Section 220 of the Technical Specifications is an obligation upon the Contractor to ensure that the temporary state of the site of the Works during the construction stage, and the Contractor's methodology of operation shall not cause unforeseen erosion in the environs of the Site.

As stated in Sub-Sections 220.4 "Method of Measurement" and 220.5 "Basis of Payment" of the Technical Specifications, no specific measurement and payment will be made for the Contractor's discharging of this obligation.

**SECTIONS 221 - 227: Not Used**

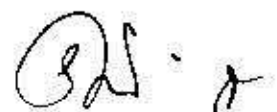

**SECTION 228  
SUBGRADE PREPARATION**

**228.1 - DESCRIPTION:**

This work shall consist of preparing the subgrade for the placing of base or sub base in accordance with these Specifications and in reasonably close conformity with the lines, grades, dimensions and cross section shown on the Drawings.

This item is only to be used for any portion of the Contract to be paved without grading and refers to compaction ordered by the Engineer of in situ material which will form the subgrade in cuttings where additional compaction is necessary for the state of compaction of the in situ material to meet the Specifications.

Clause 228.1 of Section VII, General Specifications, Volume 3 refers to compaction ordered by the Engineer of in situ material which will form the subgrade in cuttings where additional compaction is necessary for the state of compaction of the in situ material to meet the Specifications.

**228.2 - MATERIALS:**

Refer Sub Section 207.9 – Subgrade

**228.3 - CONSTRUCTION METHODS:**

All work shall be performed in accordance with the applicable provisions of Sections 207 and 211.

Subgrade preparation shall include the entire width of the subgrade. Excavation material shall be used to bring eroded areas to the Drawing cross section. If sufficient material is not obtained from the subgrade preparation, the Contractor shall obtain additional suitable material.

The subgrade material shall be compacted to the specified density as an integral part of the embankment fill construction and measured as 'fill'. Additional compaction will be necessary in some of the cut locations where the in situ subgrade material fails to meet the specified subgrade compaction standard. Item 228.001 of the Bill of Quantities covers compaction of the subgrade within those cut locations as directed by the Engineer.

**228.4 - METHOD OF MEASUREMENT:**

The quantity of work executed will be measured in square metres of "Subgrade Preparation" as determined from lines and dimensions shown on the Drawings. When borrow is necessary to complete the subgrade preparation item, it will be measured and paid for under the provisions of Section 211 and no additional payment will be made under this section.

**228.5 - BASIS OF PAYMENT:**

The quantity, determined as provided above, will be paid for at the contract unit price for the item listed below, which price and payment shall be full compensation for doing all the work prescribed in a workmanlike and acceptable manner, including all labour, tools, equipment, and incidentals necessary to complete the work.

**228.6 - PAY ITEM:**

ITEM	DESCRIPTION	UNIT
228.001	Compacted Subgrade (provisional)	Square metre

The subgrade material shall be compacted to the specified density as an integral part of the embankment fill construction and measured as 'fill'. Additional compaction will be necessary in some of the cut locations where the in situ subgrade material fails to meet the specified subgrade compaction standard. Item 228.001 of the Bill of Quantities covers compaction of the subgrade within those cut locations as directed by the Engineer.



**SECTION 229  
SHOULDERS AND DITCHES**

**229.1 - DESCRIPTION:**

This work shall consist of trimming, sloping, shaping, grading, scarifying, and compacting already excavated shoulders road side drains and ditches including inlets and outlets to pipe culverts, and constructing new shoulders and ditches where necessary, in accordance with these Specifications and in reasonably close conformity with the lines, grades, and cross sections shown on the Drawings or established by the Engineer.

**229.2 - SHOULDERS:**

Shoulder rounding shall be formed and compacted as soon as possible after the surfacing item is completed, or as directed by the Engineer, to the grade and cross section shown on the Drawings.

The character and operation of the equipment shall be such that the pavement will not be damaged. Pavement damage by these operations shall be repaired, or removed and replaced by the Contractor to the satisfaction of the Engineer, without extra compensation. Upon evidence of such damage, the Engineer may require the discontinuance of the methods used and the work to be executed by other methods. The final dressing shall be by hand methods if so required. Shoulders shall be constructed of suitable material obtained on the project or of selected material as designated on the Drawings. Surplus or unsuitable material shall be removed and disposed of as directed, which shall include shaping shoulders under existing guardrail to edge of the fill. The entire shoulder area shall be uniformly compacted by rollers, mechanical tampers, or hand methods, and finally dressed to true section.

**229.3 - DITCHES:**

Existing ditches Existing ditches and road side drains shall be trimmed, sloped, and cleaned, and inlets and outlets to existing structures opened and shaped to a uniform grade as directed by the Engineer. Mortared stone pitched lining and chutes shall be constructed in drains and ditches having gradients greater than 4% as directed by the Engineer.

**229.4 - METHOD OF MEASUREMENT:**

The quantity of "1 m Rounding" to shoulders works executed will be the number of linear metres rounded in accordance with the Drawings and/or instructed and accepted by the Engineer.

The Quantity of ditch trimming works measured will be for the number of linear metres of trenches (both old and new) trimmed and accepted by the Engineer.

Mortared stone pitched lining and chutes shall be constructed in drains and ditches having gradients greater than 4% as directed by the Engineer

**229.5 - BASIS OF PAYMENT:**

The quantities, determined as provided above, will be paid for at the contract unit price bid for these pay items, which price and payment shall be full compensation for doing all the work prescribed in a workmanlike and acceptable manner, including all labour, tools, equipment, material, and incidentals necessary to complete the work.





**229.6 - PAY ITEMS:**

ITEM	DESCRIPTION	UNIT
228.001	1.0 m wide rounding to shoulder	Linear metre
229.002	Ditch Trimming	Linear metre

**SECTIONS 230 - 239: Not Used**

821 A

**SECTION 240  
CLEANING CULVERTS, INLETS AND MANHOLES**

**240.1 - DESCRIPTION:**

This work shall consist of complete removal of obstructions and thorough cleaning of trash, dirt and other debris from existing culverts, and their appurtenant structures; e.g., inlets, manholes, etc.; when appropriate or so designated, in a manner determined by the Contractor and acceptable to the Engineer.

**240.3 - CLEANING METHODS:**

Methods employed and equipment utilized by the Contractor for cleaning culverts and their appurtenant structures; e.g., inlets, manholes, etc., shall be acceptable to the Engineer.

Cleaning procedures employed shall insure that the removal and disposal of obstructions, trash, and debris be accomplished such that the existing structure being cleaned is not damaged and deposition on, or damage to, adjacent and downstream property will be avoided. Likewise, the cleaning methods shall minimize as much as practicable, pollution and sedimentation of receiving streams, rivers, or other bodies of water and clogging of, or damage to, downstream drainage structures.

**240.4 - METHOD OF MEASUREMENT:**

"Cleaning Culverts", "Cleaning Inlets" and "Cleaning Manholes" will be measured by the unit and will be the number of such existing structures that are actually cleaned.

The bidders should obtain indicative information from site inspection.

**240.5 - BASIS OF PAYMENT:**

The quantities, determined as provided above, will be paid for at the contract unit prices bid for the items below, which prices and payments shall be full compensation for doing the work prescribed in a workmanlike and acceptable manner, including all labour, tools, equipment, supplies and incidentals necessary to complete the work.

Payment will be for cleaning existing facilities only, if considered necessary by the Engineer. Keeping such items clean during the Contract Period is deemed to be included for in the Contract Sum..

**240.6 - PAY ITEMS:**

ITEM	DESCRIPTION	UNIT
240.001	Clean culvert (provisional)	Number
240.002	Clean inlet (provisional)	Number
240.003	Clean manhole (provisional)	Number

*Bi*

**DIVISION 300  
BASES**

Sections 301 – 306	Not Used	
Section 307	Crushed Aggregate Base Course	1
Section 308	Traffic Bound Base Course and Shoulder to Existing Roads	5
Sections 309 - 310	Not Used	
Section 311	Open Graded Free Draining Base Course	10
Sections 312 - 313	Not Used	
Section 314	Aggregate Sub-base	13
Section 315	Stabilized Soil Sub-bases and Bases	16

BA

**DIVISION 300  
BASES**

**301 through 306 Not Used**

**307 - CRUSHED AGGREGATE BASE COURSE**

**307.1 - DESCRIPTION:**

The crushed aggregate base course shall be composed of crushed material from existing stockpiles or borrow sources outside the Right of Way in accordance with the requirements of Division 700 of these Specifications. Materials used for base course construction shall exhibit a minimum CBR strength of 80% when compacted in accordance with the Specifications.

Aggregate for Crushed Base Course shall be Class 1 aggregate in accordance with Section 704 of the Technical Specifications.

The work will be accepted in accordance with these Specifications and the applicable requirements

**307.2 - MATERIALS:**

The crushed aggregate base course shall be composed of crushed material excavated from within the project limits, in accordance with the requirements of Division 700 of these Specifications.

Aggregate for Crushed Base Course shall be Class 1 aggregate in accordance with Section 704 of the Technical Specifications.

Subbase material required shall be composed of material meeting the requirements of the Technical Specifications excavated from within the Right-of-Way boundaries or from borrow sources outside the Right-of-Way boundaries.

The Bidders' attention is drawn to the upper typical cross section on Drawing. The typical cross section illustrates that various segments of cutting for subsequent road development construction stages (consisting of future road widening) may be utilized for the production of additional material where there is a shortfall of material for the construction of the Works. Limits are indicated in the Plan and Profile drawings. The approval of the Engineer shall be obtained for such widening of cuttings where widening is not indicated in the drawings as a requirement of the Works, and such approval will not be unreasonably withheld.

**307.2.1 - Quality Control Testing:**

Quality control of the crushed aggregate base course is the responsibility of the Contractor. The Contractor shall maintain equipment and qualified personnel to perform all sampling and testing necessary to determine the magnitude of the various properties of the material governed by the Specifications and shall maintain these properties within the limits of the Specifications.

The Contractor shall design a quality control plan detailing the methods by which the quality control program will be conducted. This plan, prepared in accordance with the guidelines set forth in the appropriate portions of AASHTO, T180, shall be submitted to the Engineer at the pre construction conference. The work shall not begin until the plan is reviewed for conformance with the contract documents.

Handwritten signature or initials in the bottom right corner of the page.

**307.2.2 - Acceptance Testing:**

Acceptance sampling and testing of crushed aggregate base course is the responsibility of the Engineer, except for furnishing the necessary materials. Quality control sampling and testing performed by the Contractor may be used by the Engineer for acceptance.

**307.2.3 - Sampling and Testing:**

Frequency of sampling and testing shall be in accordance with the Contractor's quality control plan. The minimum frequencies shall be as indicated in applicable portions of Crushed aggregate shall be sampled in accordance with AASHTO-T2-91- Aggregate Sampling Procedures.

**307.2.4 - Acceptance Procedure:**

Material conforming to the specification requirements will be accepted at full contract price. Material failing to comply with the quality requirements of Table 704.6.2 shall not be incorporated into the work. Acceptance of crushed aggregate base course for compaction and for gradation shall be in accordance with 307.2.4.1.

**307.2.4.1 - Acceptance Plan:**

Acceptance for compaction shall be on an area-by-area basis. An area shall consist of a single layer of not more than 1,500sq.m. being placed. An area shall be divided into five equal sized sub-areas. One moisture and in-situ density measurement shall be carried out at a random location within each of the sub-areas either by the nuclear densometer method or the sand replacement method to the approval of the Engineer.

For any sub-area where the degree of compaction is less than specified in Section 717 then a further two in-situ density tests shall be carried out in that sub-area as directed by the Engineer and where the average of the three tests carried out in the sub-area exceeds the specified degree of compaction the area shall be accepted. If the average is less than the specified degree of compaction, no additional material shall be placed on that layer until it has been reworked to meet the specified requirements.

Acceptance for gradation shall be on the basis of test results on consecutive random samples from an area. An area shall be considered as the quantity of material represented by an average test value, not to exceed five sub-areas. Generally at the beginning of the project, the average shall be started on the second sample in accordance with AASHTO T27-93. A sub-area is the quantity of material represented by a single gradation test. In the case where only one sample is taken, this sub area shall be considered the area. The material shall be sampled and tested in accordance with 307.2.3. The gradation test results shall be plotted on a control chart in accordance with AASHTO T27-93. When the average, or when the most recent three consecutive individual test values fall outside the limits of Table 704.6.2, the area of material represented will be considered as non-conforming to the extent that the last of its sub areas is non-conforming.





## CONSTRUCTION METHODS

### 307.3 - EQUIPMENT:

Any machine, combination of machines, or equipment which will handle the material without undue segregation and produce the completed base course meeting these Specifications for handling, spreading, moistening, mixing and compacting may be used when approved by the Engineer.

### 307.4 - PLACING:

Prior to the placing of any base course material on the subgrade, the subgrade shall meet the applicable requirements of 207.9 or Section 228. The profile grade of the sub grade shall be such that the specified thickness of the base course may be obtained. No base shall be placed when the sub grade does not meet density and/or grading requirements or when it is sufficiently wet that its surface can be marred by construction equipment.

The base course shall be placed and shaped on the prepared surface in layers to achieve the compacted thickness shown on the Drawings. When more than one layer is required, each layer shall be shaped and compacted to the required density before the succeeding layer is placed. Each layer shall be kept at least 150 metres ahead of the succeeding layer. Tailgating will not be permitted. If power graders are used for spreading, the material shall be placed in windrows and uniformly and thoroughly mixed prior to final spreading and compaction.

### 307.5 - COMPACTING:

Each layer shall be compacted. The moisture content shall be maintained at a level sufficient to facilitate compaction. Required density and testing shall be in accordance with the provisions of Section 717. The surface of each layer shall be maintained during the compaction operations in such a manner that a uniform texture is produced and the aggregates firmly keyed. The surface of the top layer of the base course shall be carefully trued by blading if necessary.

### 307.6 - TOLERANCE:

#### 307.6.1 - Surface Tolerance:

The completed surface shall not vary more than 10mm above or below Plan grade, or more than 10mm from a straightedge three (3) meters long applied parallel and transverse to the centreline of the pavement. Deviations shall be corrected by scarifying; adding additional approved aggregate if necessary, reshaping, and recompacting.

#### 307.6.2 - Thickness Tolerance:

The base course shall be checked for proper thickness after final compaction. The Contractor shall refill all test holes with approved base course material and adequately recompacting the material. Any deficiency in total thickness of the base course in excess of 13mm shall be corrected at the Contractor's expense.

**307.7 - MAINTENANCE:**

The surface of the completed base shall be protected against the loss of fine material by the addition of moisture when necessary, and it shall be maintained in a satisfactory and smooth condition until such time that it is surfaced or finally accepted.

**307.8 - METHOD OF MEASUREMENT:**

The quantity of works executed will be the number of approved cubic metres placed in accordance with the Drawings. Any additional work beyond the scope of the Drawings, authorized by the Engineer, will be measured in cubic metres and paid for at the Contract unit rate included in the Bill of Quantities for this work item.

Any base course constructed outside the lines, dimensions, and cross sections shown on the drawings not authorized by the Engineer, will not be measured for payment.

**307.9 - BASIS OF PAYMENT:**

The accepted quantities will be paid for at the contract unit rates contained in the priced Bill of Quantities for the pay items listed below. Such payments shall be full compensation for furnishing all the materials and executing all the works prescribed in a workmanlike and acceptable manner, including water, labour, tools, equipment, supplies, and incidentals necessary to complete the work. Material that does not conform with the requirements of this Specification shall be rejected and no payment will be made for rejected materials.

**307.10 - PAY ITEMS:**

ITEM	DESCRIPTION	UNIT
307.001	Graded crushed rock base course	Cubic metre



**SECTION 308  
TRAFFIC BOUND BASE COURSE AND SHOULDER TO EXISTING ROADS**

**308.1 - DESCRIPTION:**

This work shall consist of scarifying and reshaping the existing surface and reconditioning the same by the addition of approved materials as required, in accordance with these Specifications and in reasonably close conformity with the lines, grades, depths, and typical cross sections shown on the Drawings and/or established by the Engineer.

**308.2 - MATERIALS:**

Traffic bound base course or shoulder shall be composed of materials meeting the requirements of 704.6 for the class shown on the Drawings except that 704.6.3 shall not apply.

**308.2.1 - Quality Control Testing:**

Quality control is the responsibility of the Contractor. The Contractor shall maintain equipment and qualified personnel to perform all sampling and testing necessary to determine the magnitude of the various properties of the material governed by the Specifications and shall maintain these properties within the limits of the Specifications.

The Contractor shall design a quality control plan for detailing the methods by which the quality control program will be conducted. This plan, prepared in accordance with the guidelines set forth in the appropriate portions of AASHTO T99, T180, shall be submitted to the Engineer at the pre construction conference. The work shall not begin until the plan is reviewed for conformance with the contract documents.

**308.2.2 - Acceptance Testing:**

Acceptance sampling and testing is the responsibility of the Engineer, except for furnishing the necessary materials.

The Engineer for acceptance may use quality control sampling and testing performed by the Contractor.

**308.2.3 - Sampling and Testing:**

Frequency of sampling and testing shall be in accordance with the Contractor's quality control plan. When aggregate is used as a shoulder material for resurfacing projects and these projects have a resurfacing depth of less than 75mm, and where the shoulder area is not boxed out, gradation samples may be taken from the stockpile prior to placement. The minimum frequencies shall be as indicated in applicable portions of AASHTO-T2-91, Aggregate Sampling Procedures.

**308.2.4 - Acceptance Procedure:**

Material conforming to the specification requirements will be accepted at full contract price. Material failing to comply with the quality requirements of Table 704.6.2 shall not be incorporated into the work.

Acceptance for compaction and for gradation shall be in accordance with 308.2.4.1. Shoulder aggregate adjacent to higher type pavement shall be compacted by pneumatic tyre rollers.



**308.2.4.1 - Acceptance Plan:**

Acceptance for compaction of aggregate for roadway reconstruction shall be on an area-by-area basis. An area shall consist of a single layer of not more than 500 metres long width being placed. An area shall be divided into five approximately equal sized sub-areas. One nuclear, moisture and density measurement in accordance with Section 717 shall be made at a random location within each of the five sub-areas. The random locations shall be determined in accordance with AASHTO T248. If the result of five density tests on a lot indicates that at least 98 percent of the material, in accordance with the relevant specification clauses has been compacted to the specified target percentage of dry density, the area will be accepted. If less than 98 percent has been compacted to the specified target percentage of dry density, no additional material shall be placed on that layer until it has been reworked to meet the specified requirements. Reworking and retesting shall be at the expense of the Contractor. When the Engineer performs the testing in the evaluation of the reworked areas such costs may be deducted from any monies due the Contractor pursuant to Clause 37.4 of the General Conditions of Contract (Volume 2- Section V – Part I – General Conditions of Contract) of the Contract Documents.

Acceptance for compaction of shoulder aggregate adjacent to higher type pavement shall be based on visual inspection to assure that the surface of the shoulder has been compacted to the level of the finished pavement surface. Shoulder aggregate adjacent to higher type pavement shall be compacted by pneumatic tire rollers.

Acceptance for compaction of Class 7 aggregate shall be based on visual inspection to assure that the aggregate particles are arranged in a stable manner.

Acceptance for gradation shall be on the basis of test results on consecutive random samples from a area. An area shall be considered the quantity of material, represented by an average test value, not to exceed five sub-areas. A sub-area shall consist of a quantity of material represented by a single gradation test. The material shall be sampled and tested in accordance with 308.2.3. The gradation test results shall be plotted on a control chart in accordance with AASHTO T27-93.

When the average, or when the most recent three consecutive individual test values fall outside the limits of Table 704.6.2, the lot of material represented will be considered nonconforming to the extent that the last of its sub-areas is nonconforming. When a lot of material is nonconforming, then the last sub-area contained shall have its price adjusted in accordance with Table 308.6.1. In no event however, shall a sub-area of material have its price adjusted more than once, and the first adjustment, shall apply.

Acceptance for gradation of Class 7 aggregate shall be on the basis of the Contractor's written certification that the material meets the gradation requirements. Certification shall include a description of the crushing operation indicating the screens used

**308.2.4.2 - Degree of Non-conformance:**

When a sub-area of material is to have its price adjusted, the percentage point difference between the nonconforming test value and the specification limit shall be determined for each sieve size determined to be nonconforming. This value shall be multiplied by its appropriate multiplication factor as set forth in Table 308.2.4.2 to determine the degree of non-conformance on the sieve.

The total measure of non-conformance of an individual sub-area is the sum of all non-conformances on the various sieve sizes of that sub-area.

Acceptance for gradation shall be on the basis of test results on consecutive random samples from a lot. A lot shall be considered the quantity of material, represented by an average test value, not to exceed five sub-areas. A sub-area shall consist of a quantity of material represented by a single gradation test. The material shall be sampled and tested in accordance with 308.2.3. The gradation test results shall be plotted on a control chart in accordance with AASHTO T27-93. When the average, or when the most recent three consecutive individual test values fall outside the limits of Table 704.6.2, the lot of material represented will be considered nonconforming to the extent that the last of its sub-areas is nonconforming. When a lot of material is nonconforming, then the last sub-area contained shall have its price adjusted in accordance with Table 308.6.1. In no event, however, shall a sub-area of material have its price adjusted more than once, and the first adjustment, which is determined, shall apply.

TABLE 308.2.4.2

NONCONFORMING SIEVE SIZE	MULTIPLICATION FACTOR
50 mm	1.0
37.5 mm	1.0
19 mm	1.0
4.75 mm	1.0
425 $\mu$ m	1.5
150 $\mu$ m	2.0
75 $\mu$ m	2.5

When the total degree of non-conformance has been established and it is 12.0 or less, the material will be paid for at an adjusted contract price as specified in Table 308.6.1.

When the degree of non-conformance is greater than 12.0, the nonconforming sub lot shall be resolved on an individual basis, requiring a special investigation by the Engineer to determine the appropriate course of action to be followed.

**CONSTRUCTION METHODS**

**308.3 - RECONSTRUCTING ROADWAY OR SHOULDER USING ADDITIONAL AGGREGATE:**

**308.3.1 - Surface Preparation and Spreading of Aggregate:**

The existing surface shall be scarified to a depth of 50 mm or as shown on the Drawings. When existing shoulders are sloped steeper than the nominal 6 - 4 percent, the existing shoulder material shall be shaped to achieve that slope prior to addition of aggregate. Sub grade soil or ditch soil shall not be mixed with the loosened material. The loosened material shall then be broken and reshaped to form a uniform grade and cross section.

The addition of material for roadway reconstruction shall then be spread evenly over the surface so formed in an amount sufficient to provide a compacted thickness equal to the thickness shown on the drawings and/or as directed by the Engineer. The loose surface of the reconstructed roadway shall then be carefully shaped and brought to the proper grade and cross section by use of a blade grader or other equipment as may be required.

Aggregate for shoulders shall be spread over the prepared surface to a width as specified in the Plans and to a depth sufficient to bring the non-compacted surface to a height of at least 25 mm above the finished pavement edge elevation. For compacted shoulder depths exceeding 75 mm,



the differential from the pavement edge elevation must be increased to assure that the loose aggregate thickness is approximately equal to 1 1/3 times the compacted thickness. The loose aggregate is then to be shaped to proper grade and cross section maintaining the height differential.

#### **308.3.2 - Compaction and Finish:**

Compacting or rolling shall start along the edge and proceed towards the centre, except that on super elevated curves compacting shall progress from the lower to the upper edge and shall continue until the stone is firmly set or keyed. When directed by the Engineer, the Contractor shall sprinkle the base with water in sufficient quantity to attain proper compacting. After final rolling, the surface shall be sprinkled with water at intervals as directed by the Engineer.

The roadway surface shall then be checked with a three (3) metre long straight edge and a crown board, and any unevenness more than 10mm in three (3) metres shall be corrected and re-rolled. Shoulder surfaces adjacent to higher type pavement need not be checked with the straightedge.

Each layer shall be compacted. The moisture content shall be maintained at a level sufficient to facilitate compaction. Required density testing shall be in accordance with the provisions of Section 717. The surface of each layer shall be maintained during the compaction operation in such a manner that a uniform texture is produced and the aggregates firmly keyed. The surface of the top layer shall be carefully trued by blading if necessary.

#### **308.3.3 - Roadway Surface Tolerance:**

The completed roadway surface shall not vary more than 10mm or below plan grade, or more than 10mm from a straightedge 3.0 metre long applied parallel to and perpendicular to the centreline of the pavement. Deviations shall be corrected by scarifying; adding additional approved aggregate if necessary, reshaping, and recompacting.

#### **308.3.4 - Maintenance:**

When a surface is to carry traffic before receiving a surfacing or pavement, the Contractor shall maintain the surface until final acceptance and prevent ravelling by the application of additional aggregate or water, or both, as may be required to keep the base tightly bound.

#### **308.4 - RECONDITIONING ROADWAY WITHOUT ADDING AGGREGATE:**

When reconditioning of roadway without addition of aggregate is specified, the work shall be carried out as prescribed below. The existing roadway shall be scarified to the depth of 50 mm or as shown on the Drawings and to the width of the complete roadway or as shown on the Plans. The loosened material shall then be reshaped to form a uniform grade and cross section. It shall then be rolled. Compacting and rolling shall start along the edge and proceed towards the centre, except that on super elevated curves compacting shall progress from the lower to the upper edge. When directed by the Engineer, the Contractor shall moisten the scarified material to attain proper compacting. Blading and watering of the surface, if ordered, shall be continued during the rolling operations.

The material shall be compacted in accordance with the requirements of 308.3.2.

The surface shall be satisfactorily maintained until the base or surface course has been placed. If required, additional water shall be applied to prevent ravelling.

32 8

In case of a breakdown of the automatic equipment, the Engineer may permit manual operation for a reasonable time, normally not to exceed 48 hours, while the equipment is being repaired.

The quantity of work executed, for reconditioning the roadway without adding aggregate will be measured by the square metres. Computations of the area shall approved length placed measured along the centreline of the roadway surface and the width of the base shown on the drawings and/or approved by the Engineer, plus any authorized area of any widening, turnout, or intersection, measured separately.

It is not envisaged that "Reconditioning Roadway without Adding Aggregate" as per Sub-Section 308.4 of the Technical Specifications will form part of the Works under the Contract.

**308.6 - BASIS OF PAYMENT:**

The quantities, determined as provided above, will be paid for at the contract unit prices the pay items listed below. Such prices and payments shall be full compensation for furnishing all the materials including water for compaction, scarification and manipulation of existing surface, and doing all the work prescribed in a workmanlike and acceptable manner, including all labour, tools, equipment, supplies, and incidentals necessary to complete the work.

**308.6.1 - Price Adjustment:**

Aggregates not conforming to the gradation requirements as described in 308.2.4.1 will be paid for at the adjusted contract price based on the degree of non-conformance as in Table 308.6.1.

**TABLE 308.6.1**

**ADJUSTMENT OF CONTRACT PRICE FOR  
GRADATION NOT WITHIN SPECIFICATIONS**

<b>DEGREE OF NONCONFORMANCE</b>	<b>PERCENT OF CONTRACT PRICE TO BE REDUCED</b>
1.0 to 3.0	2%
3.1 to 5.0	4%
5.1 to 8.0	7%
8.1 to 12.0	11%
Greater than 12 *	

\* The Engineer, in Consultation with the Client will make a special evaluation of the material and determine the appropriate action. Pending resolution of the matter, additional lifts of base or pavement shall not be placed over the nonconforming material.

**308.7 - PAY ITEMS:**

<b>ITEM</b>	<b>DESCRIPTION</b>	<b>UNIT</b>
308.001	Graded crushed rock base course(Provisional)	Cubic metre

**SECTIONS 309 - 310 Not Used**

**SECTION 311  
OPEN GRADED FREE DRAINING BASE COURSE**

**311.1 - DESCRIPTION:**

This work shall consist of constructing a base course of coarse stabilized aggregate spread and compacted on a prepared surface in accordance with these specifications and in reasonably close conformance with the lines, grades, thickness, and typical cross sections as shown on the Drawings or as established by the Engineer. It is the intent to allow the Contractor a choice between asphalt stabilizer and Portland cement stabilizer.

It is not envisaged that Open Graded Free Draining Base Course will form part of the Works.

**311.2 - MATERIALS:**

Depending on the alternative chosen, (asphalt or Portland cement) the materials shall conform to the requirements of the following subsections of Division 700.

<b>Material</b>	<b>Subsection</b>	
Aggregate*	703.1, 703.2, 703.3, 703.4	
Performance Graded binders**	705.5	Standard grade for area
Portland cement***	701.1	Type 1
Water***	715.7	
Curing Material***	707.10	

\*\* Asphalt stabilized applications only.

\*\*\* Portland cement applications only.

**CONSTRUCTION METHODS**

**311.3 - GENERAL:**

General requirements shall comply with the applicable portion of 401.3 of the Specifications.

**311.4 - COMPOSITION OF OPTIONAL STABILIZING MIXTURES:**

If the asphalt, stabilized alternative, is used, the asphalt cement shall be confined to 2.0 percent, plus or minus 0.5 percent by weight of the mix. If Blast Furnace Slag is used, the asphalt cement may be increased.

If the Portland cement stabilized alternative is chosen, the cement shall be Type 1 and shall have a cement content of 90 kg +/-2 kg per cubic metre.

**311.5 - TESTING:**

Quality control testing by the Contractor shall be in accordance with 307.2.1 (for Portland cement bases) or 307.2.4 (for bituminous stabilized bases) of the Specifications. Unless otherwise specified, compaction testing shall be waived.

**311.6 - WEATHER AND SEASONAL LIMITATIONS:**

Weather and seasonal limitations shall be in accordance with 401.8 (for asphalt applications) or 551.9 (for Portland cement applications).

**311.7 - EQUIPMENT:**

Depending on the alternative used, equipment shall meet the applicable requirements of 401.6, or 551.5, whichever is appropriate.

**311.8 - PREPARATION AND BATCHING OF MATERIALS:**

Preparation of materials for asphalt applications shall conform to the requirements of 401.7 of the Specifications except that the asphalt cement shall be heated within a temperature range of 120°C-135°C and temperature of the mix shall be within the range of 95°C- 120°C C.

Preparation of materials for Portland cement applications shall conform to the requirements of 551.6.

**311.9 - MIXING AND TRANSPORTING REQUIREMENTS:**

The materials used in asphalt mixes shall be mixed in a asphalt concrete mixing plant that has been inspected and approved by the Engineer. Transportation of such mixes shall be in accordance with 401.9.7 of the Specifications.

The materials used in Portland cement mixes may be mixed at a central mix plant, in a transit mix truck or a pug mill type mixer. Regardless of which type of equipment is used, the mixing time shall be a minimum of two minutes once all component materials are batched.

**311.10 - PLACING, SPREADING, AND/OR COMPACTING:**

Placement of the stabilized material shall be by acceptable spreading equipment to the appropriate line, grade and thickness. Acceptable equipment includes asphalt pavers for asphalt stabilized bases and spreader boxes, self-propelled spreaders or conventional concrete placing equipment for Portland Cement stabilized bases.

A four to ten tonne steel wheel tandem roller shall be used to compact the asphalt stabilized free draining base material. The number of roller passes shall be two or three unless otherwise directed. In the case of the asphalt stabilized aggregate, the mat temperature, at the time of initial rolling, shall be between 65°C and 80°C) unless otherwise directed. In the case of the asphalt-stabilized aggregate, the purpose of the rolling is to compact the base sufficiently to support the weight of the equipment that will place the next layer or pavement. The compacted base is to be porous so that water will drain through it. The base is not to be compacted to the point that it is not free draining or that the aggregate is crushed.

Handwritten signature or initials in the bottom right corner of the page.

**311.11 - CURING:**

Portland cement stabilized bases, immediately following spreading, shall be cured with the use of white polyethylene sheeting.

**311.12 - TOLERANCE:**

Base tolerance shall meet the requirements of 302.11 for asphalt-stabilized bases .

**311.13 - MAINTENANCE:**

The Contractor shall maintain the base course porous and free from being contaminated or clogged by deleterious material, transported and deposited by construction equipment, traffic, etc., until the next layer of the pavement is placed. The Contractor shall also maintain the final surface of the base course true to specified line, grade and cross section until such time that the pavement is placed.

**311.14 - METHOD OF MEASUREMENT:**

The quantity of work executed will be the number of approved cubic metres placed in accordance with the lines, dimensions and cross sections shown on the Drawings. Any additional work beyond the scope of the original plans authorized by the Engineer will also be measured as work executed.

Base course constructed outside Drawings or designated will not be measured for payment.

**311.15 - BASIS OF PAYMENT:**

The quantity, determined as provided above, will be paid for at the contract unit price bid for the pay item listed below. This price and payment shall constitute full compensation for furnishing all the materials and doing all the work prescribed in a workmanlike and acceptable manner, including labour, tools, equipment, supplies, and incidentals necessary to complete the work.

**311.16 - PAY ITEM:**

ITEM	DESCRIPTION	UNIT
311.001	Open graded free draining base course	Cubic metre

It is not envisaged that Open Graded Free Draining Base Course will form part of the Works.

**SECTIONS 312 - 313 Not Used**





**SECTION 314  
AGGREGATE SUBBASE**

**314.1 - DESCRIPTION:**

This work shall consist of furnishing, spreading, and compacting one or more courses of aggregate on a subgrade prepared accordance with Section 228 and in accordance with these Specifications, and in reasonably close conformity with the lines, grades, depths, and typical cross sections shown on the Drawings or established by the Engineer. The work shall be carried out in local roads as well as in the main road.

Subbase aggregates are designated as Grade 1 and Grade 2. All material used for subbase construction shall conform to the requirements of Grade 1 Subbase Aggregate.

Sub-base materials are designated as Graded Crusher run Granular materials.

All material used for subbase construction shall conform to the requirements of Grade 1 Subbase Aggregate

All material used for subbase construction shall conform to the requirements of Grade 1 Subbase Aggregate.

**314.2 - MATERIALS:**

**314.2.1 - General:**

All materials are to be approved by the Engineer prior to use.

The material shall be of such quality that it will bind readily to form a firm, stable sub base. Should the character of the material be such that insufficient fine or coarse materials are produced to properly bind and stabilize the sub-base, the Contractor shall furnish additional approved fine or coarse materials to accomplish stabilization.

Materials used for subbase shall exhibit a minimum CBR strength of 30% when compacted in accordance with the Specifications.

**314.2.2 - Grade 1 Sub-base Aggregate:**

Grade 1 subbase aggregate shall be composed of crushed stone.

Material shall conform to the requirements of Table 704.6.2, Class 5, except that (1) the percent passing the No. 200 (75  $\mu$ m) sieve shall not exceed 15, (2) the liquid limit and plasticity index shall not exceed 25 and 6 respectively and; (3) the sub-base material shall be free of deleterious material.

**314.2.3 - Grade 2 Sub-base Aggregate:**

Grade 2, Sub-base aggregate shall be composed of streambed or pit gravel, shale, chert, or red-dog, unless one type is specifically called for on the Drawings.

The material shall not have a maximum dimension greater than two-thirds the thickness of the course being placed. The plasticity index shall be not greater than six as determined by ASTM D

424 and the liquid limit shall be not greater than 25 as determined by ASTM D 423, both reported to the nearest whole number.

There shall be no deleterious material whatsoever in the subbase aggregates used in the Works. Deleterious material shall generally be determined in accordance with the codes referred to in the tabulation in Sub-Section 704.6.4 of Volume 3, Technical Specifications, Division 700 but the Engineer's decision on any material which he determines to be not adequately covered by those codes shall be final.

### CONSTRUCTION METHODS

#### 314.3 - EQUIPMENT:

Any machine, combination of machines, or equipment which will handle the material without undue segregation and produce the completed Sub-base meeting these Specifications for handling, spreading, moistening, mixing, and compacting may be used when approved by the Engineer.

#### 314.4 - PLACING:

Prior to the placing of any Sub-base course material on the subgrade, the subgrade shall meet the applicable requirements of 207.9. The profile grade of the subgrade shall be such that the specified thickness of the Sub-base will be obtained. No Sub-base shall be placed when the subgrade is sufficiently wet that its surface can be marred by construction equipment.

The Sub-base shall be placed and shaped on the prepared subgrade, or any other surface, in layers to achieve the compacted thickness shown on the Drawings. When more than one layer is required, each layer shall be shaped and compacted to the specified density before the succeeding layer is placed. Each layer shall be kept at least 150 metres ahead of the succeeding layer. Tailgating will not be permitted. If power graders are used for spreading, the material shall be placed in windrows, uniformly and thoroughly mixed, prior to final spreading and compaction.

#### 314.5 - COMPACTING:

Acceptance for compaction shall be on an area-by-area basis. An area shall consist of a single layer of not more than 1,500sq.m. being placed. An area shall be divided into three equal sized sub-areas. One moisture and in-situ density measurement shall be carried out at a random location within each of the sub-areas either by the nuclear densometer method or the sand replacement method to the approval of the Engineer.

For any sub-area where the degree of compaction is less than specified in Section 717 then a further two in-situ density tests shall be carried out in that sub-area as directed by the Engineer and where the average of the three tests carried out in the sub-area exceeds the specified degree of compaction the area shall be accepted. If the average is less than the specified degree of compaction, no additional material shall be placed on that layer until it has been reworked to meet the specified requirements.

#### 314.6 - TOLERANCE:

The completed surface shall not vary more than 13mm above or below plan grade. Deviations shall be corrected by scarifying, and adding additional approved aggregate if necessary, reshaping, and recompacting.

The subbase course shall be checked for proper thickness after final compaction. The Contractor shall refill all test holes with approved material and adequately recompacting the material.

Any deficiency in total thickness of the subbase in excess of 25mm shall be corrected.

**314.7 - MAINTENANCE:**

The surface of the completed subbase shall be protected against the loss of fine material by the addition of moisture when necessary, and the surface shall be maintained in a satisfactory and smooth condition until such time that it is covered by a succeeding course or finally accepted.

**314.8 - METHOD OF MEASUREMENT**

The quantity of executed will be measured in cubic metres, complete in place and accepted, as determined from the lines, dimensions, and cross sections shown on the Drawings and/or authorized by the Engineer.

Subbase constructed outside the lines, dimensions, and cross sections shown on the Drawings will not be measured for payment.

**314.9 - BASIS OF PAYMENT:**

The approved quantities, determined as provided above, will be paid for at the contract unit price bid for the pay items listed below. These prices and payments shall be full compensation for furnishing all the materials and executing all the work prescribed in a workmanlike and acceptable manner, including water, labour, tools, equipment, supplies, and incidentals necessary to complete the work.

**314.10 - PAY ITEMS:**

ITEM	DESCRIPTION	UNIT
314.001	Granular Sub-base to main highway	Cubic metre
314.002	Granular Sub-base to major roads	Cubic metre
314.003	Granular Sub-base to minor roads	Cubic metre
314.004	Granular Sub-base to estate roads	Cubic metre

**SECTION 315  
STABILIZED SOIL SUBBASES AND BASES**

**315.1- DESCRIPTION**

This work shall consist of forming a stabilized subbase composed of granular material with lime and water, constructed in one or more layers on a prepared and accepted lower layer, in accordance with the Specification and the lines, levels, grades, dimensions and cross sections shown on the Drawings and as required by the Engineer.

Where subgrade/sub-base is to be constructed in accordance with this Section all references to base shall be taken to refer to subbase.

Where subgrade/sub-base is to be constructed in accordance with this Section all references to base shall be taken to refer to subbase.

**315.2- MATERIALS**

**315.2.1- Soil**

Soil to be stabilized shall be material from areas either on or off the line of the road. The soil shall be free from contamination by topsoil, vegetation and other organic matter, and any deleterious materials of a different nature from the soil required.

**315.2.2- Stabilizing Agent**

The stabilizing agent used for chemical stabilization of subgrade and subbase material shall be lime.

**315.2.3- Lime**

Lime shall be *freshly burnt* hydrated lime in the form of a dry powder consisting essentially of Calcium Hydroxide Ca (OH) with or without a small percentage of Calcium Oxide (CaO) and magnesium oxide or hydroxide, (MgO) or Mg (OH)

The chemical composition shall conform to the following: -

Percentage by weight Ca (OH),            minimum 90%  
Percentage by weight CaO,                maximum 5%  
Percentage by weight of free water, maximum 4%

The gradation shall conform to the following: -

B. S. Sieve Sizes		Percentage Passing
Mm	µm	
3.35		100
2		99.0 - 100
	600	97.5 - 100
	75	80.0 - 100

#### **315.2.4- Water**

Water shall be clean and free from harmful matter and shall conform to the requirements of AASHTO T106, T 154, T 162. Water thus tested and found to have a pH value less than 5.0 or more than 8.5 shall not be used.

Furthermore, water shall not contain more than 400 parts per million by weight of sulphate.

Any indication of unsoundness, marked change in time of setting or reduction of more than 10% in strength of mortar mixtures made with the water, as compared with mixtures made with distilled water shall be cause for rejection.

### **CONSTRUCTION METHODS**

#### **315.3- Mix Design**

The proportions of lime and the moisture content required will be determined on site by the Engineer and may be varied by him from time to time. The mix will be so selected that the strength shall be at least equal to the required strength as indicated in the Drawings or in the Contract documents. The Contractor shall construct test areas, at locations and of dimensions determined by the Engineer, before construction of the actual subbase layer commences.

#### **315.4- Strength Requirements of Stabilized Soil**

The strength of lime stabilized subbase shall be measured in terms of the CBR of the material at 97% maximum dry density at AASHTO T-180 compaction. The samples shall be tested for the CBR value seven days after stabilization, which period shall include seven days of moisture curing and seven days soaking in water.

The CBR value required shall be 70% in the case of subbase.

#### **315.5- Equipment**

Equipment shall be suitable for the work specified and consist of motor graders, soil cement stabilizers, water tankers, pneumatic rollers, vibrating rollers, steel wheel rollers, cement spreaders and asphalt spreaders together with dump trucks and shall have met with the approval of the Engineer as to type, capacity, design and manufacture before construction is permitted. The equipment shall be capable of constructing the layer to meet the requirements specified and to permit the measurements required.

#### **315.6- Initial Testing**

The Engineer will make and test trial mixes using different proportions of stabilizer and will select mix proportions that give strength of samples, made and cured in the laboratory, not less than 105% of the required strength nor greater than 125% of the required strength indicated in Clause 315.4. This will be called the required mix.

#### **315.7- Mix Control**

The entire operation of mixing and compacting lime stabilized layers shall be subject to close control and frequent testing will be required as the work proceeds to ensure that the strength and density requirements are achieved.

Handwritten signature or initials in the bottom right corner of the page.



The mix proportions and uniformity of mixing of the stabilized material shall be such that for any 20 consecutive samples taken before compaction, on any one day, and compacted in the laboratory, the average strength shall be not less than the required strength. Not more than two of these samples shall have less than the required strength. If because of low production on any particular day less than 20 samples are taken then all samples must be up to standard.

The Contractor shall assist the Engineer in all ways to sample soil for stabilizing at least 10 days in advance of its use so that any necessary adjustments to the mix design may be made. To ensure good sampling it will normally be necessary to remove overburden and stockpile sufficient soil for construction 10 days ahead at all times. Failure to do so will make the Contractor responsible for replacing at his own expense any sections of work that are unsatisfactory on account of an unsuitable mix.

### **315.8- Blending of Soils (Mechanical Stabilization)**

Mechanical stabilization (blending) shall either be done at the site or at the borrow pits or at designated central yards.

When site mixing is done, the soil to be blended shall be spread uniformly on the prepared surface in the required proportions and then pulverized and mixed by means of a rotovator, disc harrow, rotary tiller or any other approved equipment or a combination of these equipment. The pulverizing and mixing shall be continued until uniformity of the mix is achieved as far as practicable.

Alternatively, windrowing using a motorgrader shall mix the different soils after pulverization.

Manual mixing using pickaxes, spades etc. shall be carried out only on small areas with the approval of the Engineer.

### **315.9- Mixing**

Either mix in place or central plant mix methods may be used at the option of the Contractor. In any method the materials shall be dry mixed before addition of water so that balls of stabilizer are not formed when water is added. Water content shall be within two percentage points of the optimum moisture content for the compaction required. Placing and mixing shall be completed and compaction started within 3 hours of the time of the addition of water for lime-stabilized mixes.

Where material is brought into the road from elsewhere and mix in place methods are used, the mix in place method will be such that the material to be mixed shall be pulverized to the full depth required. The stabilized material shall be placed in uncompacted layers not exceeding 0.2 m at the discretion of the Engineer. In order to ensure that the amount of material pulverized is correct it will be necessary to compact the material in position, to approximately the final surface before pulverizing and mixing and final compacting.

The Contractor shall give the Engineer every facility for checking the actual quantities of lime used in the construction and in case of central plant mix shall provide equipment such that the Engineer can check the proportions by calibration tests.

### **315.10- Spreading and Compaction**

The mixed material shall be placed and compacted between robust forms secured against movement and conforming to the requirement for forms in Section 551.8. Adjoining sections of previously

completed subbase shall be neat, clean and treated at the interface with a slurry of cement, sand and water. Construction joints shall be trimmed to be vertical before adjoining sections are constructed.

The layer shall be compacted throughout its depth to 97% of the maximum dry density obtained from AASHTO test method T 180. Compaction shall be uniform over the whole area and shall be done in such a way that no ruts are formed. The use of both steel tyred rollers and pneumatic tyred rollers will be required. Compaction shall be completed to the required standard within 2 days for lime-stabilized mixes.

#### **315.11- Curing**

Protection of the course against rapid drying shall be done immediately after compaction by means of a curing membrane of asphalt applied as emulsified asphalt or as a cutback asphalt. No stabilized subbase construction shall be started at any time unless there is sufficient approved asphaltic material on site to provide a curing membrane immediately on completion of compaction.

Emulsified asphalt shall be a rapid setting type containing not less than 58% by weight of asphalt and shall be distributed by pressure distributor at a rate of at least 1 litre of emulsion per square metre.

Should it be necessary for construction equipment or other traffic to run on the asphaltic curing coat before it has hardened, the surface shall be sanded.

At the time the asphaltic material is applied, the subbase shall contain ample moisture for proper curing and to prevent penetration by the asphalt. If necessary, water shall be applied.

#### **315.12- Traffic**

Heavy equipment except for equipment that required for construction adjoining sections would not be permitted to drive over completed portions until curing is completed. Turning areas and areas which it is not possible to close to traffic on completed portions shall be protected by a layer of stable material of not less than 50mm compacted depth. This requirement will apply when half width construction is not possible. Traffic shall not be permitted on lime-stabilized layers until they have been cured for 7 days. Traffic control shall be as required by the Engineer.

#### **315.13- Protection**

The stabilized layer shall be protected as necessary to maintain the surface within the tolerance specified and to prevent failure from traffic or other causes.

#### **315.14- Determination of Thickness**

After final compaction, test holes shall be made in the stabilized layer to determine the thickness at intervals not greater than 100 metres. Any part of the stabilized subbase which fails to meet the Specification or which originally having met the Specification subsequently suffers damage or deformation shall be rebuilt to Specification to the full depth of the course at the Contractor's expense. The addition of thin layers to raise the level of low areas will not be permitted.

#### **315.15- Surface Requirements**

Surface deviation in excess of 10mm from a straight edge 3 metres long applied to the surface parallel to the centre line of the road and 10 mm from a template laid transversely, shall be corrected

by loosening, adding or removing material, reshaping and recompacting, provided this is done within the time allowed for compaction.

The full thickness of stabilized layer shall be completed by the end of each day's work.

### 315.16- Acceptance

Where tests carried out shows that the strengths specified have not been achieved, the layer shall be rejected, in which case the layer shall be reworked and made good in the case of a lime stabilized layer.

### 315.4- MEASUREMENT AND PAYMENT

This item will be measured as the number of cubic metres of material complete in place, and accepted. Measurement will be based on the cross section area of the stabilized layer shown in the Drawings and the actual length measured horizontally along the centre line of the surface of the road. Lime will be measured as the number of kilograms of material either as the actual quantities used or as the quantity calculated from the specified mix proportions expressed as kilograms per cubic meter of compacted, finished layer, whichever is the less. Any lime used in excess of the specified mix proportions, whether used in order to obtain the specified strength or for any other reason will be provided by the Contractor at his own expense and will not be included in the measured quantities for payment. Test sections shall be measured for payment, but their removal, if required, shall be regarded as incidental to the work and shall not be paid for.

This work measured as provided above shall be paid for at the Contract unit prices for chemically stabilized subbase as detailed below. The payment shall be full compensation for furnishing all materials complete in place including handling, placing, mixing, compacting and for all labour, equipment, tools and incidentals necessary to complete the work.

### 315.5- PAY ITEMS

ITEM	DESCRIPTION	UNIT
315.001	Chemically stabilized Sub-base thickness 150mm (Provisional)	Cubic Metre
315.001	Mechanically stabilized Sub-base thickness 150mm (Provisional)	Cubic Metre
315.003	Lime (Provisional)	Kilogram

The only chemical stabilisation provided for in the Contract is that of the lime stabilisation of subbase material which would otherwise not meet the specifications. Prior to embarking on such stabilisation procedures it is essential that the Engineer shall be satisfied that other alternatives are not practicably available at lower cost to the Employer. Accordingly, the Contractor shall obtain the Engineer's prior approval before engaging in chemical stabilisation.

Mechanical stabilisation consists of the improvement of the strength and grading of granular material by the addition of particle size fractions which would reduce the amount of voids in naturally occurring or initially manufactured material in order that such material shall meet the specification for the particular requirement for which that material is to be utilised.

**DIVISION 400**

**BITUMINOUS PAVEMENTS**

Section 401	Hot-Mix Asphalt Base, Wearing, Patching and Levelling Courses	1
Section 402	Hot-Mix Asphalt Skid Resistant Pavement	18
Sections 403 - 404	Not Used	
Section 405	Surface Treatments	20
Sections 406 - 407	Not Used	
Section 408	Tack Coat	24
Section 409	Prime Coat	28
Sections 410 - 414	Not Used	
Section 415	Removing Existing Pavement Surface	32

BN &

**DIVISION 400  
BITUMINOUS PAVEMENTS**

**SECTION 401 HOT-MIX ASPHALT BASE, WEARING, AND PATCHING  
AND LEVELING COURSES**

**401.1 - DESCRIPTION:**

This work shall consist of laying one or more courses of hot-mix asphalt (HMA), mixed mechanically in a plant, composed of aggregate and asphalt material, with or without reclaimed material, on a prepared foundation in accordance with these Specifications. The material is to be laid in reasonable close conformity with the lines, grades, weights or depths, and cross sections shown on the Drawings and/or as instructed by the Engineer. The use of any reclaimed material will be at the sole discretion of the Engineer.

The work will be accepted in line with the applicable requirements of these Specifications.

**401.2 - MATERIALS:**

The materials shall conform to the requirements of the following Sub-Sections of Division 700:

<b>Material</b>	<b>Sub-Section</b>
Performance Grade Binders:	705.5
Penetration Grade Binders:	705.6
Coarse Aggregate:	703.1 through 703.3
Fine Aggregate:	702.3
Mineral Filler:	702.4

**CONSTRUCTION METHODS**

**401.3 - GENERAL:**

The Contractor's proposed work methods shall be submitted to the Engineer for review and approval prior to the start of work. This review may require modification of the proposed methods to provide the desired end product. All equipment, tools, machinery, and plant shall be maintained in a satisfactory working condition.

**401.4 - COMPOSITION OF MIXTURES:**

**401.4.1 - General:**

The aggregate for use in the designated mixture shall consist of a mixture of aggregate [coarse, fine, reclaimed material (if approved) or mixture thereof] and mineral filler if required. It shall be the responsibility of the Contractor to determine, and gain the Engineer's approval, for the percentage of reclaimed material, if any, to be used in the mix. The amount and grade

82 A



of virgin PG Binder to be used in the RAP designs shall be determined in accordance with Materials Procedure AASHTO T170-00.

**401.4.2 - Plant Mix Formula:**

The HMA shall be designed in accordance with Asphalt Institute Manual Series MS-2 Marshall Method. Reference shall also be made to Overseas Road Note 19, TRL Limited, UK, for guidance. The Contractor shall submit, to the Engineer for his approval, a proposed Plant Mix Formula (PMF) for each combination of aggregate and asphalt material for each type of HMA to be produced. The PMF gradations shall be within the tolerances set forth in Table 401.4.2. If the PMF requires revision, it will be returned to the designer for correction and re-submission.

Each submission shall contain the following:

- i) Identification of the source and type of materials used in the design.
- ii) The aggregate blend percentages and the percentage for each sieve fraction of blended aggregate considered the desirable target for that fraction.
- iii) The percentage of asphalt binder representing the optimum asphalt content for the PMF submitted, which is to be considered the desirable target percentage.
- iv) The temperature of the completed mixture at the plant, shall be within  $\pm 10$  °C of the median mix temperature established by the design temperature-viscosity chart or as recommended by the asphalt supplier.
- v) The ratio (calculated to the nearest one-tenth percent) of the Fines to Asphalt (FA). The ratio is defined as the percentage of aggregate passing the 75  $\mu$ m (No. 200) sieve, divided by the percentage of asphalt content calculated at the percentage optimum asphalt content of the design.

If it becomes necessary to change aggregate sources, a new PMF shall be developed and submitted for approval. Should the PG Binder source be changed on a mix design, the plant technician shall prepare a set of Marshall test specimens and two maximum specific gravity test specimens with the new binder at the optimum asphalt content. If the percent air voids and percent voids-filled-with-asphalt remains within the tolerance limits of AASHTO T165, T167 and the voids-in-mineral-aggregate, stability, and flow values meet the minimum requirements, then the binder from the new source may be used without redesigning. The results of this testing shall be sent to the Engineer. The mix with the new binder shall then be required to go through a new mix verification process as described in Section 401.6.2.

At no time shall different grades or sources of PG Binders be mixed together in the same storage tank. When it is necessary to switch to a new binder grade, or binder of the same grade from a different source, the tank shall be drawn down as far as possible, normally to the top of heating coils, before refilling with the new binder. The new binder shall be circulated thoroughly before restarting production.

Table 401.4.2 as referred to in Sub-Section 401.4.2 of the Technical Specifications shall be as follows:

TABLE 401.4.2

AGGREGATE GRADATION FOR ASPHALT CONCRETE		
Sieve Size (mm)	Asphalt Concrete Wearing Course	Asphalt Concrete Binder Course
	Percentage by Weight Passing Sieve	
28	100	100
20	100	90 - 100
14	90 - 100	-
10	59 - 94	56 - 82
5	38 - 69	36 - 58
2.36	25 - 48	21 - 38
1.18	20 - 40	15 - 32
0.6	15 - 32	10 - 26
0.3	10 - 23	6 - 20
0.15	4 - 15	3 - 13
0.075	3 - 12	1 - 7
MIX PROPERTIES FOR ASPHALT CONCRETE		
Percent asphalt content by weight of total mix	4.2 - 6.5	3.5 - 5.5
Asphalt grade	60/70	60/70
Minimum Marshall Stability, 75 blows each end of specimen (kN at 60°C)	8.0	8.0
Flow value (mm)	2 - 4	2 - 4
Voids in total mix (VIM) (%)	3 - 5	4 - 6
Min. voids in mineral aggregate (%)	13	13
VIM 4%	-	14
VIM 5%	-	-
Filler/bitumen ratio	0.5 to 1.5	0.5 to 1.5

BW 8

**401.5.1 - Test Methods:**

- MP 700.00.06 - Aggregate Sampling Procedures
- AASHTO T11 - Materials Finer than No. 200 (75  $\mu$ m) Sieve in Mineral Aggregates by Washing
- AASHTO T27 - Sieve Analysis of Fine and Coarse Aggregates
- AASHTO T30 - Mechanical Analysis of Extracted Aggregate
- AASHTO T164 - Quantitative Extraction of Bitumen from Bituminous Paving Mixtures
- AASHTO T165 - Effect of Water on Cohesion of Compacted Bituminous Mixtures
- AASHTO T166 - Bulk Specific Gravity of Compacted Bituminous Mixtures
- AASHTO T167 - Compressive Strength of Bituminous Materials
- AASHTO T168 - Sampling Hot-Mix Asphalt
- AASHTO T209 - Theoretical Maximum Specific Gravity of Bituminous Paving Mixtures
- AASHTO T230 - Determining degree of pavement compaction of bituminous aggregate mixtures.
- AASHTO T245 - Resistance to Plastic Flow of Bituminous Mixtures Using Marshall Apparatus
- AASHTO T269 - Percent Air Voids in Compacted Dense and Open Bituminous Paving Mixtures
- AASHTO T275 - Bulk specific gravity of compacted bituminous mixtures using paraffin coated specimens.
- AASHTO T287 - Asphalt Content of Bituminous Mixtures by the Nuclear Method
- AASHTO TP53 - Asphalt Content of HMA by the Ignition Method
- ASTM D1559 - Resistance to Plastic Flow of Bituminous Mixtures Using Marshall Apparatus (For Base-I HMA only)
- ASTM D2950 - Test Method for Density of Bituminous Concrete by Nuclear Method

**401.6 - CONTRACTOR'S QUALITY CONTROL:**

**401.6.1 - Technician Requirements and Quality Control Plans:**

Quality control of HMA is the responsibility of the Contractor. The Contractor shall maintain equipment and qualified personnel including at least one certified HMA Technician at each plant. The technician shall be in charge of all plant quality control activities such as mix

proportioning and adjustment and all sampling and testing activities necessary to maintain the various properties of HMA within the limits of the Specification. A certified HMA Inspector may handle sampling and testing activities under the supervision of the plant technician.

The Contractor shall maintain equipment and qualified personnel including at least one certified Compaction Technician at each project. A certified Compaction Technician shall perform all testing necessary to assure compaction of the HMA meets Specification requirements. The Contractor, or Contractor-Producer, shall design a workable quality control plan, detailing the type and frequency of sampling, and testing deemed necessary to measure and control the magnitude of the various properties of the HMA governed by these Specifications. This plan shall be submitted to the Engineer for review prior to production of material under this Specification.

#### 401.6.2 - Plant Mix Formula Field Verification:

Once a Plant Mix Formula has been established and approved the Contractor shall carry out a plant production trial and a laying trial to satisfactorily demonstrate the ability to produce the mix in compliance with the design and the Specification and to demonstrate methods and compliance with pavement construction requirements in accordance with the Specification and drawings. A minimum plant trial shall comprise three batches and a minimum laying trial shall comprise a single width mat length not less than 100m. The cost of the trial or trials shall be borne by the Contractor.

#### 401.6.3 - Quality Control Testing Requirements:

After the PMF field verification has been successfully completed, sampling frequency and requirements for quality control testing shall be as set forth in AASHTO T230.

If the Engineer determines that a mix cannot be consistently produced within the tolerance limits of the specified design properties, approval of the mix may be revoked and the Contractor will be required to provide a new mix design.

#### 401.6.4 - Plant Production Tolerances

After the Plant Mix Formula has been established and approved all mixes furnished shall conform thereto within the following tolerances:

REQUIREMENT	BINDER & WEARING COURSE
Aggregate filler grading:	
Retained on 10mm & larger sieves	± 5%
Passing 5mm to 0.15mm sieves	± 3%
Passing 0.075mm sieve	± 1.5%
Binder content	± 0.3%
Temperature of mix at discharge	+ 10°C

**401.7 - ACCEPTANCE TESTING:**

Acceptance testing of HMA is the responsibility of the Engineer.

**401.7.1 - Surface Tolerance:**

The Engineer using Bump integrator will determine the smoothness of the riding surface over a minimum length of two lots of 340m. Equipment required to determine the smoothness of the riding surface shall be provided by the Contractor

The smoothness testing will generally be accomplished within 30 days after the project is complete.

The pavement will be divided into sampling areas of one-tenth (0.1) lane kilometre each.

Each area shall exhibit a smoothness measurement, expressed in International Roughness Index of values between 1.5-2.3 m/Km.

When compaction is completed on the course, it shall present a uniform surface, true line and grade, conforming to the cross section shown on the Drawings. When tested with a straightedge, approximately three (3) metres in length, and a template of the specified dimensions, the finished base course shall not show a deviation greater than 6mm and the finished wearing course shall not show a deviation from the required surface greater than 5 mm.

The Contractor shall provide the straightedge and template for checking the surfaces, and an employee to use them under the direction of the Engineer. Any irregularity of the surface exceeding the limits specified shall be corrected. Loosening the mixture and adding new material shall correct depressions occurring after the initial rolling. High places shall be corrected by removing excess material.

Areas of completed courses found to be defective shall be removed and replaced with approved mixtures laid in accordance with these Specifications, and no additional compensation will be allowed for materials used or work involved in replacing defective areas.

**401.7.2 - Compaction:**

Acceptance testing for compaction shall be performed in accordance with the area-by area method described in 401.7.2.1 based on the lift thickness given below. When HMA is placed in areas that require a non-uniform thickness or is tapered to a thin edge the Engineer shall determine the method of acceptance testing.

**401.7.2.1 – Area-by-Area Testing:**

Randomly located nuclear density tests to ASTM D2950 will be performed in accordance with the area-by area test procedure described in Contractor's approved Quality Control Plan. The pavement shall be divided into areas not exceeding 300 metres of paving lane. A randomly located density test shall be conducted in each area. The density shall be within the range of 92.0 to 96.0% of the theoretical maximum density of the approved mix design (AASHTO T209) or the maximum density established under 401.6.2, Plant Mix Formula Field Verification. If the density is outside the range, an additional five tests shall be conducted for



the area and the average of all ten tests shall be used to judge acceptance of the area in accordance with Table 401.13.3.

Acceptance testing is not required on areas in which a full-size roller is restricted from properly compacting the mat. These areas shall be compacted to the satisfaction of the Engineer.

**401.7.3 - Thickness:**

When a uniform thickness of 75mm or more is specified, excluding resurfacing, cores shall be taken to verify the thickness of the compacted pavement. The Contractor shall be responsible for making good the core holes with asphaltic (bituminous) material meeting the specifications for the layer cored. For thicknesses less than 75 mm the layer thicknesses shall be checked non-destructively by survey level and string-line methodology.

Cores will be taken at the direction of the Engineer at random locations. The sampling frequency shall be approximately five cores per 800 metres of two-lane construction

The Engineer may also elect to take additional cores when needed to resolve problems related to pavement thickness.

The thickness shall be considered acceptable if it falls within the ranges given in the following table.

Wearing Course	± 4mm
Binder Course	± 6mm

The Contractor shall be responsible for making good the core holes with asphaltic (bituminous) material meeting the specifications for the layer cored.

For thicknesses less than 75 mm the layer thicknesses shall be checked non-destructively by survey level and string-line methodology.

**401.8 - WEATHER RESTRICTIONS:**

HMA shall only be placed when the surface is dry and the weather conditions are such that proper handling, finishing, and compaction can be accomplished.

**401.9 - EQUIPMENT:**

**401.9.1 - Plant:**

All Plant producing HMA shall provide documented evidence of compliance with current requirements of the Central Environmental Authority (CEA) Regulations.

All plants shall meet the requirements set forth in AASHTO M156.

**401.9.2 - Dust Collector:**

An efficient dust collecting system shall be provided to prevent the loss of fine material. The material collected may be returned to the mixture at a uniform rate or discarded.

**401.9.3 - Truck Scales:**

Truck scales shall be provided at each Plant, except that truck scales are not required at properly calibrated automatic batching plant facilities which are equipped with digital printout equipment, and which load the trucks directly from the mixer or weigh hopper in a surge or storage bin.

The Contractor shall provide a weigh person. The weigh person shall certify that the weight of the HMA, as determined either by the truck scales or from the digital printout of the batch weights, is correct.

Each truck shall be weighed empty prior to each load, except at automatic batch plants approved to operate without truck scales.

All truck scales shall be mounted on solid foundations, which will insure them remaining plumb and level.

Approval and sealing of scales shall be conducted at the frequency determined by the Engineer, and when the plant is moved, or upon the request of the Engineer. The Engineer shall be notified of any scale malfunctions when material is being furnished to the Project.

A digital recorder shall be required on all truck scales. The digital recorder shall produce a printed record of the gross, tare and net weights, and the time, date, truck identification, and project number. Provision shall be made for constant zero compensation and further provision shall be made so that the scales may not be manually manipulated during the printing process. The system shall be interlocked so as to allow printing only when the scale has come to rest. In case of breakdown of the automatic equipment, the Engineer may permit manual operation for a reasonable time, normally not to exceed 48 hours, while the equipment is being repaired.

The scales shall be of sufficient size and capacity to weigh the loaded trucks that are used for delivery of HMA from the plant.

**401.9.4 - Test Weights:**

As part of its standard equipment, each plant which, proportions aggregate by weight shall provide a minimum of ten 22.68 kg test weights for the purpose of maintaining the continued accuracy of weighing equipment. Plant which proportion asphalt material by weight shall furnish, in addition to the above, one 2.268 kg test weight.

**401.9.5 - Surge and Storage Bins:**

During the normal daily operation of the plant, HMA may be stored in a surge or storage bin for a maximum of 12 hours, provided the bin has received prior evaluation and acceptance through the inspection by the Engineer. The temperature of the material at time of placement and compaction shall be sufficient to properly perform these activities.

Longer silo storage times, up to 24 hours, may be permitted for dense graded HMA if the storage silo is insulated and/or heated to assure that the proper mix temperature is maintained. The gates at the bottom of the storage silo shall be adequately heated and sealed when the HMA is held for the extended period of time. An inert gas system may be used to purge the silo of oxygen to prevent oxidation of the asphalt. The HMA delivered from the storage silo shall meet all of the Specification requirements.

When HMA is stored for the extended time period it shall not be used until the temperature has been checked and the HMA has been visually inspected for hardening of the mix and stripping of the asphalt from the aggregate. Approval of the extended storage time may be revoked if it is determined through inspection and/or testing that the extended storage is having a detrimental effect on the HMA.

Loading of trucks through the storage bin will only be permitted when a minimum 25 tonne buffer of material is being maintained or an amount as recommended by the bin manufacturer. Means shall be provided for loading the trucks directly from the mixer when the storage bin is not in operation.

#### **401.9.6 - Inspection of Equipment and Plant Operations:**

The Engineer shall have access to the plant to assure the adequacy of the equipment in use, to inspect the conditions and operation of the plant, to verify weights, to verify the proportion and character of materials, and to determine if specified temperatures are being maintained in the preparation of the mixture.

#### **401.9.7 - Trucks for Transporting Mixture:**

To avoid stop-start operations of the Hotmix paver sufficient trucks must be available to avoid paver stoppages.

The inside surfaces of trucks shall be thinly coated with a soapy water or a mixture with not more than ten percent lubricating oil. The use of diesel fuel, kerosene, or similar solvent-based products, which can dissolve the asphalt film from the aggregate particles, will not be permitted. Any commercial release agent, which can be certified as harmless to the mix may be used, however, the Engineer reserves the right to restrict any release agent that is shown to cause problems with the mix. In the case of mixtures composed of PG Binders, which contain polymer modification, truck surfaces should be coated with a release agent recommended by the binder supplier. All excess coating material shall be removed from the truck bed prior to loading the HMA.

All truck beds shall be insulated with approved material. No trucks shall be used which cause segregation of the materials, which show large oil leaks, or which cause undue delays in delivery of material. All trucks shall be provided with a waterproof cover and a hole in the body in order to conveniently checking the temperature of the load. Covers shall be suspended slightly above the mixture, extend over the sides of the truck be securely fastened to eliminate air infiltration and to prevent water from coming in contact with the mixture.

#### **401.9.8 - Laboratory:**

A testing facility or laboratory, as described in Division 100 of these Specifications, proximity shall be placed in close of the HMA plant. Plant operations must be visible from within the laboratory.

**401.9.9 - Spreading Equipment:**

Spreading equipment shall be self-contained and of sufficient size, power and stability to receive, distribute and strike-off the asphalt mixture at rates and widths commensurate with the typical sections and other details shown on the plans. The spreading equipment shall be provided with an activated screed or strike-off assembly equipped to be heated. Approval of spreading equipment by the Engineer will be based on the demonstrated capability of the equipment to place the mixture to the required cross-section, profile and alignment in an acceptable, finished condition ready for compaction. Specialized equipment or hand methods approved by the Engineer may be employed to spread the asphalt mixture where the use of standard full scale spreading equipment is impractical due to the size or irregularity of the area to be paved.

Paving machines shall be equipped with mechanical or automatic grade and slope controls. The use of automatic grade and slope controls with a travelling straight edge shall be required only when specified on the Drawings or in the Proposal. Both the grade and slope controls shall be in working order at all times. In the event of failure of the automatic controls, the Contractor will be permitted to finish the day's work using manual controls but will not be allowed to resume work the following day until the grade and slope controls are in proper working order.

**401.9.10 - Compaction Equipment:**

Self-propelled steel-wheeled, pneumatic tired and/or vibratory rollers may perform compaction. Hand held rollers or vibrating plates might be used in small inaccessible areas if approved by the Engineer. Prior to use on any project the roller shall be inspected to see that it is in good mechanical condition. The total weight, weight per metre of width (steel-wheeled), and average ground contact pressure (pneumatic-tired) shall be documented.

**401.10 - PAVING OPERATIONS:**

**401.10.1 - Cleaning and Sweeping:**

Immediately prior to the arrival of the paving mixture, the existing base or surface shall be thoroughly cleaned by the use of tools and equipment as may be required to remove all mud, dirt, dust, and other caked or loose material foreign to the type of treatment or surface being placed. The cleaning shall be done to a minimum width of zero point five (0.5) metres on each side beyond the width of the surface being placed.

**401.10.2 - Patching, Levelling, and Scratch Courses:**

**401.10.2.1 - Patching and Levelling:**

A tack coat shall be applied to the existing pavement prior to placing patching and levelling.

Patching and levelling shall be placed at various locations throughout the project to remove irregularities in the existing pavement such as dips, or to raise the outside edge of the existing pavement to provide a uniform template prior to paving.

Compaction of patching and levelling shall be performed with three-wheel (steel) or pneumatic tire rollers.



**401.10.2.2 - Scratch Course:**

A tack coat shall be applied to the existing pavement prior to placing a scratch course.

The scratch course shall be placed to the limits designated on the plans. Scratch course can be placed with a paving machine or grader with shoes. The paving machine screed or grader blade shall be set to drag on the high areas of the existing pavement only depositing material in ruts and other depressions. The wearing course or at least one lift of base course should be placed over the scratch course prior to maintaining traffic in the lane where the scratch course has been placed. All repairs to a scratch course due to traffic damage shall be at the Contractor's expense.

Compaction of a scratch course shall be performed with a three-wheel (steel) or pneumatic tire roller.

**401.10.3 - Spreading and Finishing:**

Before spreading any material, the contact surfaces of curbs, gutters, manholes, and of adjacent Portland cement concrete pavement edges shall be painted or sealed with asphalt material. Exact edge of pavement, except on concrete, shall be established by a string or chalk line for a distance of not less than 150 metres ahead of the spreading operation.

For mixes produced with unmodified asphalts the temperature of the mixture at the time of placement shall be within the temperature requirements of the PMF. The PMF temperature range shall be within the master temperature range of 121°C and 170 °C. The mix temperature shall be monitored by inserting a dial type thermometer into the mix through the hole in the truck bed.

The temperature of the completed mix, when measured at the plant, shall be within the tolerance as established by the PMF. The first load, which demonstrates temperatures outside of that range, may be accepted provided that the temperature is still within the master temperature range. However, no additional loads of material shall be run out of the plant until necessary steps are taken to re-establish the temperature of the mix within the plant tolerance. When measured at the project site, the temperature of the mix shall be within the tolerance established by the PMF. The first truckload of material, which demonstrates temperatures outside of that range, or any trucks in transit at that time, may be accepted provided temperatures are within the master temperature range. However, the plant shall immediately be notified that no additional loads of material are to be dispatched until necessary action is taken to re-establish temperature within PMF specification limits.

The temperature of each truckload of material shall be monitored for compliance and the Engineer may reject any truckload of material, which exceeds this maximum temperature. Mixes produced with asphalts that contain modifiers for high or low temperature performance enhancement shall meet the temperature requirements recommended by the asphalt supplier which will be referenced on the PMF.





**401.10.4 - Rolling Procedure:**

Shoulders, ramps, and similar areas shall be compacted in the same method as the mainline.

During rolling, roller wheels shall be kept moist with only enough water to avoid picking up material. Fuel oil on roller wheels or pneumatic tires is not allowed. Rollers shall move at a slow but uniform speed with the drive roll or wheels nearest the paver.

If rolling causes material displacement, the affected area shall be loosened at once with lutes or rakes and restored to their original grade with loose material before being re-rolled. Heavy equipment, including rollers, should not be permitted to stand on the finished surface before it has thoroughly cooled or set.

Mat temperature shall be measured using a non-contact infrared thermometer. The required density shall be obtained prior to the mat temperature reaching 80 °C. The Contractor shall be allowed to lower this temperature to 74 °C if they can demonstrate during the first day of placement of each lift on each project that additional densification can be achieved without causing any pavement distress.

**401.10.5 - Joints:**

The longitudinal joint in any layer shall offset that in the layer immediately below by approximately 150mm; however, the joint in the top layer shall be at the centreline of the pavement if the roadway comprises two lanes of the width, or at lane lines if the roadway is more than two lanes in width. The transverse joint in any layer shall offset that in the layer immediately below by approximately 1,800mm.

Joints between the existing and new HMA pavement shall be "heeled in" to the existing surface at the beginning and at the end of the project and at all other locations where the new pavement terminates against an existing HMA pavement. These joints as well as the transverse joints between one days production and the next shall be carefully constructed and shall be formed by cutting back into the existing section to expose the full depth of the course. All joints shall be squared up to the full vertical depth of the course to be placed, and a tack coat of asphalt material shall be applied if called for by the Engineer. Transporting back sufficient hot material to fill any space left uncovered by the paver shall form joints adjacent to curbs, gutters, or adjoining pavement. The joint shall be set up with lutes to a sufficient height to receive the full compactive effort from the rollers. After rolling, joints shall be at the same elevation as the adjacent lanes or sections and shall be free from ridges or depressions.

The use of side beams to form joints shall be to the approval of the Engineer.

Transverse joints shall be checked for smoothness with a three (3) metre straight edge provided by the Contractor. All surface irregularities shall be corrected prior to proceeding with paving operations.

**401.11 - PROTECTION OF PAVEMENT AND TRAFFIC CONTROL:**

The Contractor shall be responsible for the protection of HMA surfaces from damage by their equipment and personnel. When the construction of HMA surfaces is undertaken on projects under public traffic and the road surface is 4.9 metres wide or greater and the ADT is 400 or



greater, the Contractor shall place No Passing Signs and Interim Pavement Markings to delineate the centreline or lane line of the roadway as required herein. The Contractor shall be responsible for maintaining both signs and markings until such time as the permanent markings are placed or thirty calendar days after completion of the final course whichever is less. No separate payment will be made for maintenance of these items but shall be included in the applicable pay items for initial installation. All Interim Markings shall be in conformance with the Sri Lanka Manual on Traffic Control Devices – Part I, and shall be installed by the end of the workday by placing the markings as the paving operation progresses within 300 metres of the paver. Interim Markings shall be Type LM1 and LM2 pavement markings meeting the requirements of 715.40.4.1. Payment of Interim Pavement Markings shall be incidental to the 401 Items. Removal of Interim Markings shall not be required between lifts or after placement of the final markings.

**401.11.1 - Interim Traffic Control for Two-Lane, Two-Way Roadways:**

Prior to any work, which will cover the centreline, the Contractor shall install 600mm x 750mm "DO NOT PASS" signs on permanent post at the beginning of each no passing zone throughout the length of the project. These signs shall be placed at the beginning of each no passing zone and shall be repeated every 750 metres as required.

No measurement or payment shall be made for any "Interim Traffic Control Devices".

To delineate the centreline of the roadway, the Contractor shall install yellow Interim Pavement Markings measuring 100mm x 100mm along the centreline of the roadway on 6 metre centres.

**401.11.1.1 - Temporary Pavement Markings with ADT of 3,000 or Greater:**

The Interim Pavement Markings described in Sub-Section 401.11.1 shall be permitted only for a period up to three calendar days after completion of the final course. Within this time the Contractor shall install full compliance centreline Temporary Pavement Markings (i.e. passing and no passing zones delineated) in conformance with Sections 636 and 663.

No measurement or payment shall be made for "Temporary Pavement Marking Paint".

**401.11.2 - Interim Traffic Control for One-Way Multilane Roadways:**

On all one-way multilane roadways, the Contractor shall install white Interim Pavement Markings measuring 100mm x 1200mm along the lane line. Interim Pavement Markings shall be placed on 12-metre centres.

**401.11.2.1 - Temporary Pavement Markings:**

Prior to the left lane being open to traffic, the Contractor shall install a 100mm yellow edge line. These markings shall be in conformance with Sections 636 and 663. No measurement or payment shall be made for "Temporary Pavement Marking Paint".

**401.11.3 - Interim Traffic Control for Two-Way Three-Lane Roadways:**

Prior to any work which will cover the centreline and/or lane lines, the Contractor shall install 600mm x 750mm "DO NOT PASS" signs on permanent post at the beginning of each no

Handwritten initials 'QD' and a signature.

passing zone throughout the length of the project as required. "DO NOT PASS" signs in both directions will be required for centre left turn lanes. These signs shall be placed at the beginning of each no passing zone and shall be repeated every 750 metres as required. The Contractor shall maintain signs until temporary or permanent markings are installed. No measurement or payment shall be made for any "Interim Traffic Control Devices".

The Contractor shall install Interim Pavement Markings measuring 100mm x 1200mm. Where truck climbing lanes exist, the centreline shall be marked with two parallel yellow lines separated by a 100mm space placed on 12 metre centres. Lane lines shall be marked with white lines placed on 12-metre centres. Where centre right-turn lanes exist, the centre lane shall be marked with two parallel yellow lines separated by 100mm space placed on 12 metre centres on both sides of the centre lane.

#### **401.11.3.1 - Temporary Pavement Markings:**

The Interim Pavement Markings described in Section 401.11.3 shall be permitted only for a period of up to three calendar days after completion of the final course. Within this time the Contractor shall install full compliance centreline and lane line Temporary Pavement Markings in conformance with Sections 636 and 663.

No measurement or payment shall be made for "Temporary Pavement Marking Paint".

#### **401.11.4 - Interim Traffic Control for Two-Way Four-Lane and Five-Lane Roadways:**

On all two-way four-lane and five-lane highways, the Contractor shall install Interim Pavement Markings measuring 100mm x 1200mm along the lane line and centreline where required. Centrelines shall be marked with two parallel yellow lines separated by a 100mm space placed on 12-metre centres. On five-lane roadways these markings shall be placed on both sides of the centre right-turn lane. Lane lines shall be marked with white lines placed at 12-metre centres.

#### **401.11.4.1 - Temporary Pavement Markings:**

The Interim Pavement Markings described in Sub-Section 401.11.4 shall be permitted only for a period of up to three calendar days after completion of the final course. Within this time the Contractor shall install full compliance lane line and centreline or left edge line Temporary Pavement Markings in conformance with Sections 636 and 663.

No measurement or payment shall be made for "Temporary Pavement Marking Paint".

#### **401.11.5 - Seasonal Temporary Markings:**

Unless otherwise described above, if it becomes necessary to open the roadway to traffic whether on the base or final course, for longer than 14 calendar days, the Contractor shall install full compliance Temporary Pavement Markings conforming with Sections 636 and 663.

No measurement or payment shall be made for "Temporary Pavement Marking Paint".

#### **401.12 - METHOD OF MEASUREMENT:**

The quantities of work completed, accepted, and incorporated into the completed work in accordance with these Specifications will be measured in tonnes.

Measurement of "Hot-Mixed Asphalt Base Course, Hot-Mix Asphalt Wearing Course, Hot Mix Asphalt Shoulder Paving" or "Hot-Mix Asphalt Patching and Levelling Course" will be for tonnes laid within tolerances contained in these Specifications and the dimensions indicated on the Drawings and/or as designated by the Engineer.

The number of tonnes shall be determined by the total of the weights of and weigh slips for each vehicle load weighed on an approved standard scale or from digital printout slips from an automatic batching plant. Such slips or printouts are to be certified by the Contractor as being correct, and countersigned as agreed to by an approved member of the Engineer's staff.

Truck scales shall be provided by the Contractor, except that truck scales are not required where the material is weighed at an Engineer approved, properly calibrated automatic batching plant facilities, which are equipped with digital printout equipment. The scales shall be of sufficient size and capacity to weigh the heaviest loaded trucks that are used for delivery of the material. All such scales shall be checked and calibrated at intervals no greater than 6 months.

All truck scales shall be mounted on solid foundations, which will insure their remaining plumb and level. All truck scales shall be inspected and sealed by the Department of Weights and Measures or other appropriate agencies of Sri Lanka, prior to the Engineer approving such scales.

The producer or Contractor shall provide a weigh person. The weigh person shall certify that the weight of the material, as determined either by the truck scales or from the digital printout of the weights, is correct.

Each truck shall be weighed empty prior to each load, except at automatic batch plants approved to operate without truck scales. A digital recorder shall be required on all truck scales. The digital recorder shall produce a printed record of the gross, tare and net weights, and the time, date, truck identification and project number. Provision shall be made for constant zero compensation and further provision shall be made so that the scales may not be manually manipulated during the printing process. The system shall be interlocked to allow printing only when the scale has come to rest. In case of a breakdown of the automatic equipment, the Engineer may permit manual operation for a reasonable time, normally not to exceed 48 hours, while the equipment is being repaired.

Any patching or levelling mixture placed on a subbase or base course constructed in the same Contract with HMA items shall be at the expense of the Contractor. No additional compensation will be allowed for the material or any work incidental to its placement.

If HMA is found not in compliance with the provisions of 401.6.3, production shall cease until the Contractor demonstrates that the PMF can be met.

#### **401.13 - BASIS OF PAYMENT:**

The approved quantities will be paid for at the Contract unit prices for the pay items listed below.

These prices and payment shall be full compensation for furnishing all the materials and doing all the work herein prescribed in a workmanlike and acceptable manner, including all



labour, tools, equipment, field laboratory, supplies, and incidentals necessary to complete the work.

The conditioning, cleaning, and sweeping of the existing base or underlying surface shall be considered as part of the construction of the appropriate items listed in 401.14, and no additional compensation will be allowed for "Cleaning and Sweeping".

There will be no additional compensation for tack coat material used for minor (spot) areas to be patched and levelled; the cost of this tack coat material will be included in the unit bid price for the patching Pay Item.

There will be no additional compensation for any Interim or "Temporary Traffic Control Devices" or "Pavement Markings" in connection with this item(s) of work.

**401.13.1** – If the Engineer determines that a mix has not been consistently produced within the tolerance limits of the specified design properties, approval of the mix may be revoked and no payment will be made to the Contractor for any areas so laid or for its removal.

**401.13.3** - When an area of HMA pavement does not meet the density requirements of 401.7.2, the price shall be adjusted as follows:

**TABLE 401.13.3**

**ADJUSTMENT OF CONTRACT PRICE FOR PAVEMENT DENSITY NOT WITHIN TOLERANCE OF DENSITY**

<b>Percent of Density</b>	<b>Percent of Contract Price to be Paid</b>
92% to 96%	100%
91% Provided the air voids ratio is less than 8%	98%





**401.14 - PAY ITEMS:**

ITEM	DESCRIPTION	UNIT
401.001	Hot mix asphalt concrete binder course including bituminous material	Tonne
401.002	Hot mix asphalt wearing course including bituminous material	Tonne

821 J

**SECTION 402**

**HOT-MIX ASPHALT SKID RESISTANT PAVEMENT**

**402.1 - DESCRIPTION:**

This work shall consist of constructing a Hot-Mix Asphalt (HMA) wearing course in accordance with the requirements of Section 401 with the following exceptions and additions:

**402.2 - MATERIALS:**

The coarse aggregate shall consist of gravel, slag, or other acceptable polish resistant aggregate, or combinations thereof, meeting the requirement of 703.1 through 703.3, except as amended in this Section.

When stone or gravel is specified in the contract, the coarse aggregate shall consist of gravel or other acceptable polish resistant aggregate, or combination thereof meeting the requirements of 703.1 through 703.3, except as amended in this Section. When slag is specified in the contract, the coarse aggregate shall be slag meeting the requirements of 703.3, except as amended in this Section.

The coarse aggregate or blends thereof shall have a minimum of 80 percent two-face fracture, and, except for those carbonate rocks which may be designated as acceptable polish resistant aggregate, the portion obtained on the No.4 (4.75 mm) sieve shall contain no more than 15 percent carbonate particles. Acceptable dolomite may be used alone or as a part of a coarse aggregate blend on roadways with an ADT of 10,000 or less. On roadways exceeding 10,000 ADT acceptable dolomite, may be used, only as a part of the coarse aggregate blend, but shall not exceed 50% of that blend.

The total shale (determined by ASTM), and other lightweight deleterious material (determined by ASTM C123) and friable particles (determined by ASTM C-142, AASHTO T112) shall not exceed three percent. The total thin and elongated pieces shall not exceed five percent.

**402.3 - FINE AGGREGATE:**

Fine aggregate shall meet the requirements of 702.3.

The skid resistant paving mix shall be type designated on the plans.

**402.5 - PAY ITEMS:**

ITEM	DESCRIPTION	UNIT
402.001	Hot mix asphalt – skid resistant pavement (Provisional)	Tonne
402.002	Bituminous material for hot mix asphalt (Provisional) Skid resistant pavement	Tonne

The construction of "skid resistant pavement" is 'provisional'. Accordingly it shall be the Engineer's decision as to the locations where such pavement shall be provided in the Works.

Skid resistant pavement shall conform to the requirements of Section 402 of the Technical Specifications.

Notwithstanding the requirement of Sub-Section 402.2, paragraph 4, the asphalt mix aggregate shall be free of any deleterious material.

**Sections 403 to 404 – Not Used**

BL A

**SECTION 405  
SURFACE TREATMENTS**

**405.1 - DESCRIPTION:**

This work shall consist of the construction of a wearing course, composed of bituminous material and aggregate, in one or more applications upon the completed and accepted base course or existing surface, in accordance with these Specifications and in reasonably close conformity with the lines, grades, depths, and cross sections shown on the Drawings and/or established by the Engineer. The type of surface treatment will be indicated on the Drawings.

**405.2 - MATERIALS:**

The materials shall meet the requirements of the following Sub-Sections of Division 700:

**Grading of Single Sized Aggregate for Seal Coat Treatment**

Sieve Size mm	Percentage Passing Nominal Size			
	20 mm	14 mm	10 mm	5 mm
28	100			
20	85 - 100	100		
14	0 - 25	85 - 100	100	
10	0 - 7	0 - 25	85 - 100	100
6.3		0 - 7	0 - 20	85 - 100
5			0 - 10	
3.35				0 - 20
2.36	0 - 2	0 - 2	0 - 2	0 - 10
0.075	0 - 1.5	0 - 1.5	0 - 1.5	0 - 1.5

**Table 405.1 - Properties of 80/100 pen. Grade Bitumen**

Property	Test method	Volume	
		Min	Max
Penetration at 25°C	BS 2000 or ASTM D5-86	80	100
Softening Point °C	BS 2000	47	55
Loss on heating for 5hr at 163°C			
(a) Loss by mass %	BS 2000		0.5
(b) Drop in penetration %			20
Solubility in trichloroethylene % by mass	BS 2000 or AASHTO T44	99.5	
Flash point, Cleveland Open Cup °C	AASHTO T48	232	
Thin Film Oven Test	AASHTO T179		
(a) Loss on heating %			1.0
(b) Penetration of residue, % of original		50	

82 A

Unless otherwise directed by the Engineer, any of the above types or grades of bituminous material may be used.

**Washing of Aggregates**

Where directed by the Engineer the aggregate shall be washed and dried to eliminate dust to improve bonding.

The nominal aggregate sizes for surface dressing shall be 20mm and 10mm for the first and second seal respectively. The grading for each size shall be in accordance with Table 170.1.8 and Clause 1701.3 of RDA Specifications.

The bituminous material for both seals shall be penetration grade bitumen 80/100 conforming to the above Table 405.1. The application temperature shall be 160°C to 175°C, unless approved otherwise by the Engineer."

**CONSTRUCTION METHODS**

**405.3 - WEATHER AND SEASONAL LIMITATIONS:**

Weather and seasonal limitations shall be as specified in 401.8

**405.4 - EQUIPMENT:**

Equipment shall be as in the Contractor's Quality Assurance Plan, approved by the Engineer.

**405.5 - PREPARING AND REPAIRING EXISTING SURFACE:**

This work shall be as in the Contractor's Quality Assurance Plan, approved by the Engineer.

**405.6 - CLEANING AND SWEEPING:**

This work shall be as in the Contractor's Quality Assurance Plan, approved by the Engineer.

**405.7 - APPLICATION OF BITUMINOUS MATERIAL:**

This operation shall be performed as specified in Section 401, except as modified. The bituminous material shall be applied to the prepared surface at the rate specified agreed by the Engineer.

Except when required to maintain traffic, surface treatment operations shall be done upon the full width of the section.

New bases shall receive a prime coat as specified in Section 409 and shall be allowed to thoroughly cure before starting surface treatment operations.

**405.8 - APPLICATION OF AGGREGATE:**

Immediately following each application of bituminous material, aggregate at the rate or rates called for in 405.12 shall be spread with the spreader in such a manner that the entire area being treated is uniformly covered. Trucks spreading aggregate shall be operated so that



bituminous material will be covered before the wheels pass over it. Additional aggregate shall be spread if necessary, and hand spreading shall be done to cover areas inaccessible to the spreading equipment. When directed by the Engineer, the aggregate shall be dried or moistened as required.

**405.9 - BROOMING AND ROLLING:**

Immediately following spreading of each layer of aggregate, the entire surface of the aggregate shall be broomed with a broom drag to insure uniform distribution of the aggregate. As soon as the broom dragging operation is completed, the rolling operation shall begin and continue until the aggregate is keyed into the bitumen. If so ordered by the Engineer, rolling shall be continued at proper intervals for several days. Any area that tends to ravel shall be repaired and re-rolled. Rolling shall be parallel to the centreline and shall begin at the edges of the treatment and progress toward the centre; on super elevated curves, rolling shall begin at the low edge of the curve and continue the entire width of the treatment, each trip uniformly overlapping the preceding trip.

Rolling shall cease before the aggregate is crushed to any appreciable extent. Rollers shall be the type and weight specified in 401.10.4. The number of rollers shall be sufficient to obtain compaction to the satisfaction of the Engineer. Water, to prevent adhesion of the bituminous material to the roller wheels, shall not be used in excessive amounts. The use of fuel oil, paraffin oil, and kerosene on rollers or other equipment, for the purpose of preventing material from picking up or sticking, is prohibited.

Sufficient curing time between the first and second seal shall elapse before applying the bituminous material for the second seal as agreed with the Engineer.

**405.10 - JOINTS:**

The longitudinal construction joints between adjacent lanes shall be kept clean of material foreign to the type of surface being treated. The joints shall be constructed without overlaps or gaps between the materials. The transverse joint at the end of successive sections or lanes shall be covered with paper to prevent overlapping of the bituminous material. Following its use, the paper shall be removed and disposed of satisfactorily.

**405.11 - PROTECTION OF PAVEMENT AND TRAFFIC CONTROL:**

This work shall be done as prescribed in 409.8.

**405.12 - SEQUENCE OF OPERATIONS AND QUANTITIES OF MATERIALS:**

The rate of spread of both aggregates and bituminous material shall be determined in accordance with TRL ORN 3 or as approved by the Engineer.

**405.13 - METHOD OF MEASUREMENT:**

The quantities of work executed will be measured as follows:

The approved quantity of "Double bituminous surface treatment" shall be measured by the square metre of the area complete in place and accepted.

521  
A

The approved quantity of "Patching & Levelling Aggregate" shall be measured by the tonne of material complete in place and accepted.

The method of measurement of patching and levelling aggregate shall be calculated as 401.12 above.

The weight of all surface moisture in the aggregate will be deducted from the pay quantity.

The quantity of "Bituminous Material" shall be the number of (litres) incorporated into the completed work.

The quantity of "Cleaning and Sweeping" will not be measured and paid for, but be considered as a part of the surface treatment works.

No measurement or payment will be made for any interim or temporary traffic control devices or road markings, will be made in connection with this item(s) of work.

**405.14 - BASIS OF PAYMENT:**

The quantities, determined as provided above, will be paid for at the Contract unit prices bid for the items listed below, which prices and payments shall be full compensation for furnishing all the materials and doing all the work prescribed in a workmanlike and acceptable manner, including all labour, tools, equipment, supplies, and incidentals necessary to complete the work.

There will be no additional compensation for any Interim or "Temporary Traffic Control Devices" or "Pavement Markings" in connection with this item(s) of work.

**405.15 - PAY ITEMS:**

ITEM	DESCRIPTION	UNIT
405.001	Double bituminous surface treatment (Provisional)	Square metre
405.002	Patching and levelling aggregate (Provisional)	Tonne
405.003	Bituminous material (Provisional)	Litre

Sections 406 to 407 – Not Used

**SECTION 408  
TACK COAT**

**408.1 - DESCRIPTION:**

This work shall consist of preparing and treating an existing bituminous or concrete surface with bituminous material, and cover aggregate when called for on the Drawings, in accordance with these Specifications and/or as may be instructed by the Engineer.

**408.2 - MATERIALS:**

Materials shall meet the requirements of the following Subsections of Division 700:

MATERIALS	SUBSECTION	KIND OR GRADATION
Coarse Aggregate	703.1-4	9 or 10
Fine Aggregate	702.3	
Asphalt Emulsion Primer, AEM-1 RS-1 or MS-1		SS-1, SS-1h, CBAE
*Cationic Emulsified Asphalt Water	705.11 715.7	CMS-1, CRS-1, CSS-1, CSS-2, or CSS 1h

\*May be used with aggregates other than gravel only if the aggregate asphalt combination meets the requirements of ASTM D 1664 for the dry aggregate coating test.

Unless otherwise indicated on the Drawings and/or directed by the Engineer, any of the above types or grades of bituminous material may be used.

**CONSTRUCTION METHODS**

**408.3 - WEATHER RESTRICTIONS:**

Tack coat shall be applied only when the weather and existing surface are satisfactory to the Engineer. When the surface temperature is 10°C or above, the asphalt material may be asphalt emulsion or cutback asphalt.

**408.4 - EQUIPMENT:**

Equipment shall include a power broom and power blower, a broom drag, equipment for heating bituminous material, a self-powered bituminous material pressure distributor, and an aggregate spreader. Equipment shall also include scrapers, hand brooms, shovels, and other equipment as may be necessary to thoroughly clean the base or surface.

**408.5 - PREPARING AND REPAIRING BASE OR EXISTING SURFACE:**

No tack coat shall be applied until breaks, holes, depressions, and other irregularities in the base or existing surface have been repaired and cured sufficiently to permit the tack coat to be placed in a uniform application. Hand patching will be permitted where necessary.

**408.6 - CLEANING AND SWEEPING:**

This work shall be as in the Contractor's Quality Assurance Plan, approved by the Engineer.

**408.7 - APPLICATION OF BITUMINOUS MATERIAL:**

Except when required to maintain traffic, work shall be done on the full width of the section.

After the base or surface has been cleaned, and is in a dry condition, the bituminous material shall be applied by means of a pressure distributor. The rate of application of bituminous material shall be as specified in 408.11. Application temperatures of the bituminous material shall be within the range specified in Division 700 for the particular material being used. Asphalt emulsion, type SS-1 and SS-1h, and cationic emulsified asphalt types CSS-1 and CSS-1h, shall be diluted by the addition of water when directed by the Engineer.

The tack coat shall not precede the work of placing the subsequent surface course to such an extent that the treated surface will be injured during the interim. No patching and levelling or surface courses of any type shall be applied to the tacked surface until the bituminous material is thoroughly cured and dry.

Tack coat shall not be applied over newly placed patching and levelling courses. However, to facilitate construction, minor (spot) areas that have been tacked, patched and levelled may be re-tacked and the quantity so used will be included for payment as part of the normal tack coat operation only.

The intent of the two preceding sentences is:

- (1) to provide one tack coat application on the existing surface, although two applications, one over and one under, for minor (spot) patching and levelling areas, are permitted as indicated above, and
- (2) to limit payment for such operations to one application of the tack coat upon the existing surface for the entire project.

The surfaces of sidewalks, curbs, other structures, and trees adjacent to the area being treated shall be protected in such a manner as to prevent their being spattered or marred. Material used for such protection shall be removed and disposed of in a satisfactory manner. The distributor shall not be cleaned or discharged within the right-of-way, into borrow pits, or so as to pollute or block water courses.

**408.8 - APPLICATION OF COVER AGGREGATE:**

When called for by contract documents or when directed by the Engineer, application of bituminous material shall be followed immediately with an application of clean dry aggregate at the rate specified in 408.11. The aggregate shall be spread with spreaders. Immediately after the application of aggregate, the entire surface shall be broomed with a broom drag in order to insure uniform distribution of the aggregate.

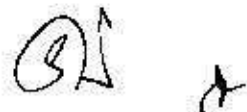

**408.9 - JOINTS:**

This operation shall be performed as prescribed in 405.10.

**408.10 - PROTECTION OF THE PAVEMENT AND TRAFFIC CONTROL:**

The Contractor shall be responsible for the protection of the surface against damage by their equipment and personnel. Traffic shall not be permitted on any part of the work under construction until the treatment has cured sufficiently to prevent ravelling or picking up under traffic. The applicable provisions of Section 636 shall apply for regulating traffic.

**408.11 - SEQUENCE OF OPERATIONS AND QUANTITIES OF MATERIALS:**

The sequence of operations and quantities of materials to be used shall be as specified unless otherwise indicated on the Drawings or directed by the Engineer.

- (i) Dry, clean and sweep as necessary and to Engineer's approval
- (ii) Where applying tack coat aggregate apply 0.9 to 1.4 litres per sq.m. of bituminous material or
- (iii) Where bituminous material is specified for use as tack coat, without tack coat aggregate, apply a 'fog' spray to the approval of the Engineer.
- (iv) Tack coat aggregate, where specified, to be spread at the rate of 5.5 to 8.0 kg per sq.m.

**408.12 - METHOD OF MEASUREMENT:**

The quantities of work done will be determined as follows:

The quantity of "Tack Coat Aggregate" shall be measured by the tonne of material complete in place and accepted, calculated as for 401.12 above.

The quantity of "Bituminous Material" for tack coat shall be the number of litres, prior to dilution in the field, approved for incorporated into the completed work.

"Cleaning and Sweeping" will not be measured but considered as part of the work items..

There will be no additional compensation for any Interim or "Temporary Traffic Control Devices" or "Pavement Markings" in connection with this item(s) of work.

The Contract involves new construction on a totally new alignment. Hence, Prime Coats and Tack coats will not require protection by the spreading of sand/aggregate over them.

Should the Contractor wish to run his site vehicles over a surface which has received prime coat he shall first obtain the approval of the Engineer. Such approval, if granted, shall require the Contractor to protect the primed surface by the spreading of sand/aggregate at a rate which shall be determined by the Engineer. The costs of such protection shall be to the account of the Contractor.

The purpose of the tack coat, when required, is to assist with adhesion between adjacent pavement layers. In the circumstances of the Contract it is not envisaged that any spreading of sand/aggregate over tack coats will be required or permitted.]

BS A



**408.13 - BASIS OF PAYMENT:**

The quantities, determined as provided above, will be paid for at the contract unit prices bid for the pay items listed below.

These prices and payments shall be full compensation for furnishing all the materials and doing all the work prescribed in a workmanlike and acceptable manner, including all labour, tools, equipment, supplies, and incidentals necessary to complete the work.

**408.14 - PAY ITEMS:**

ITEM	DESCRIPTION	UNIT
408.001	Tack coat	Lire

Q1 2

**SECTION 409  
PRIME COAT**

**409.1 - DESCRIPTION:**

This work shall consist of preparing and treating an existing surface with bituminous material, and cover aggregate if required, in accordance with these Specifications and/or as instructed by the he Engineer.

**409.2 - MATERIALS:**

Materials shall meet the requirements of the following Sub-Sections of Division 700:

MATERIAL	SUB-SECTION	KIND OR GRADATION
Coarse Aggregate	703.1 - 4	Nos 9 or 10
Liquid Asphalt		MC30, MC70
Asphalt Emulsion	705.4	
CBAE Primer or AEM-1, SS-1, or SS-1h Cationic Emulsified Asphalt	705.11	

Unless otherwise directed by the Engineer, any of the above types or grades of bituminous material may be used.

SS-1, SS-1h, CSS-1 and CSS-1h may be diluted with water.

**CONSTRUCTION METHODS**

**409.3 - WEATHER RESTRICTIONS:**

Weather restrictions shall be as prescribed in 401.8.

**409.4 - EQUIPMENT:**

The equipment shall conform to the requirements specified in 408.4.

**409.5 - PREPARATION OF SURFACE:**

The surface to be primed shall be cleaned using tools and equipment, as may be required, in such a manner as to thoroughly remove all mud, dirt, dust, loose particles or any foreign materials. The sweeping of the surface shall be just sufficient to expose the pattern of the coarse aggregate. Cleaning and sweeping shall be done for a minimum width of 300mm on each side beyond the width of the surface being treated. Material cleaned from the surface shall be removed and disposed of as directed by the Engineer.

BW A

**409.6 - APPLICATION OF BITUMINOUS MATERIAL:**

Except when required to maintain traffic, work shall be done on the full width of the section.

Bituminous material shall be heated within the temperature limits specified in Division 700 for the particular type of material being used and shall be applied to the width of the section to be primed by means of a pressure distributor in a uniform, continuous spread. The rate of application of bituminous material shall be as specified in 409.9.

Care shall be taken that the application of bituminous material at the junctions of spreads is not in excess of the specified amount. Excess bituminous material shall be squeezed from the surface. Skipped areas or deficiencies shall be corrected. Building paper shall be placed over the end of the previous applications, and the joining application shall start on the building paper. Building paper used shall be removed and disposed of in a satisfactory manner.

When traffic is to be maintained, one-way traffic will be permitted on the untreated portion of the roadbed. As soon as the bituminous material has been absorbed by the surface and will not pick up, traffic shall be transferred to the treated portion and the remaining width of the section shall be primed. The quantities, rate of application, temperatures, and areas to be treated shall be approved before application of the prime coat.

The surfaces of sidewalks, curbs, other structures, and trees adjacent to the area being treated shall be protected in such a manner as to prevent their being splattered or marred. The material used for such protection shall be removed and disposed of in a satisfactory manner. The distributor shall not be cleaned or discharged within the right-of-way, into borrow pits, or so as to pollute or block water courses.

**409.7 - APPLICATION OF COVER AGGREGATE:**

Cover aggregate shall only be used only when indicated on the Drawings, required by the Specifications, and/or instructed by the Engineer, or when needed to absorb excess bituminous material or protect the primed surface from traffic. Spreading shall be accomplished by aggregate spreaders in such a manner that the tires of the spreader at no time contact the uncovered and newly applied bituminous material.

If directed, the cover aggregate shall be moistened with water to eliminate or reduce the dust coating of the aggregate. Moistening shall be done the day before the use of the aggregate.

Immediately after the cover aggregate is spread, any deficient areas shall be covered by additional material. After the application of the cover aggregate, the surface where specified shall be lightly broomed or otherwise maintained. Maintenance of the surface shall include the distribution of cover aggregate over the surface to absorb any free bituminous material and cover any area deficient in cover coat material. The maintenance shall be conducted so as not to displace imbedded material. Excess material shall be swept from the entire surface by means of rotary brooms. The surface shall be swept at the time determined by the Engineer.

**409.8 - PROTECTION OF PAVEMENT AND TRAFFIC CONTROL:**

The Contractor shall be responsible for the protection of the surface against damage by their equipment and personnel. Traffic shall not be permitted on any part of the work under construction until the treatment has cured sufficiently to prevent ravelling or pickup under traffic.

QJ A

**409.9 - SEQUENCE OF OPERATIONS AND QUANTITIES OF MATERIALS:**

The sequence of operations and quantities of materials to be used shall be as shown below, unless otherwise indicated on the Drawings.

- i. Apply 0.5 to 1.5 litres per sq.m of bituminous material. The quantity shall be determined by trial and approved by the Engineer.
- ii. Spread 4.0 cu.m per 100.0 sq.m of 'cover aggregate' with the grading band as given below:

Sieve Size		Percentage Passing
mm	µm	
9.5		100
4.5		85 - 100
2.36		50 - 95
1.18		25 - 80
	600	10 - 40
	300	0 - 15
	150	0 - 5
	75	0 - 2

**409.10 - METHOD OF MEASUREMENT:**

The quantities of work done will be determined as follows:

The quantity of "Prime Coat Aggregate" shall be the number of tonnes of aggregate incorporated in the completed and accepted work.

The number of tonnes of "Prime Coat Aggregate" shall be determined as per 401.12 above.

The weight of all surface moisture in the aggregate will be deducted from the pay quantity.

The quantity of "Bituminous Material" for prime coat shall be the approved number of litres incorporated into the completed work.

"Cleaning and Sweeping" will not be measured and paid but considered as part of the works.

There will be no additional compensation for any Interim or "Temporary Traffic Control Devices" or "Pavement Markings" in connection with this item(s) of work.

The Contract involves new construction on a totally new alignment. Hence, Prime Coats and Tack coats will not require protection by the spreading of sand/aggregate over them.

Should the Contractor wish to run his site vehicles over a surface which has received prime coat he shall first obtain the approval of the Engineer. Such approval, if granted, shall require the Contractor to protect the primed surface by the spreading of sand/aggregate at a rate which shall be determined by the Engineer. The costs of such protection shall be to the account of the Contractor.

**Construction Document**

---

The purpose of the tack coat, when required, is to assist with adhesion between adjacent pavement layers. In the circumstances of the Contract it is not envisaged that any spreading of sand/aggregate over tack coats will be required or permitted.

**409.11 - BASIS OF PAYMENT:**

The quantities, determined as provided above, will be paid for at the Contract unit prices bid for the pay items listed below.

These prices and payments shall be full compensation for furnishing all the materials and doing all the work prescribed in a workmanlike and acceptable manner, including all labour, tools, equipment, supplies, and incidentals necessary to complete the work.

**409.12 - PAY ITEMS:**

ITEM	DESCRIPTION	UNIT
409.001	Prime coat	Litre

BA J



Sections 410 to 414 - Not Used

**SECTION 415  
REMOVING EXISTING PAVEMENT SURFACE**

**415.1 - DESCRIPTION:**

This work shall consist of preparing the existing pavement for the placement of additional courses of pavement as shown on the plans.

**415.2 - CONSTRUCTION METHODS:**

The equipment for removing the existing pavement shall be a power operated planing machine or grinder. The equipment shall be capable of accurately establishing profile grades along each edge of the machine within plus or minus 6mm by referencing from the existing pavement and able to maintain accurate depth of cut and cross-slope.

The cuttings shall be expeditiously removed from the pavement behind the planing machine or grinder. Stockpiling of material on the project site will not be permitted unless otherwise noted on the Plans or approved by the Engineer.

The machine shall have a control system providing for uniformly varying the depth of cut while the machine is in motion to prevent cutting of or damage to drainage works, manholes or other appurtenances within the paved area.

The existing pavement shall be removed to the depth, width, grade and cross-section shown on the plans or as otherwise directed by the Engineer. The manner of performing the work shall be such that the pavement is not torn, gouged, shoved, broken or otherwise injured and such that the remaining pavement is suitable as a base for a bituminous concrete overlay, or suitable as a riding surface.

The removed pavement material shall become the property of the Contractor.

Excess waste material resulting from the operation shall be removed and disposed of in a manner approved by the Engineer.

At the end of each working day, all equipment shall be removed to a location where it does not present a hazard to traffic, the pavement shall be cleaned by sweeping or flushing.

If the ground area is opened to traffic the following shall apply; at the end of each working day, any transverse vertical face shall be sloped so as not to present a hazard to traffic and any longitudinal vertical face shall not exceed 50mm.

The work covered by Section 415 of the Technical Specifications shall consist of preparing the existing pavement for the placement of new courses of pavement for connection between local road relocations and existing roads pavements, and shall be as directed by the Engineer. The unit of measurement for such pavement removal shall be the square metre as provided for in the amendment to Sub-Section 415.5 by Bid Addendum No. 1. The average depth for such pavement removal is expected to be of the order of 200 mm.

Handwritten initials and marks, including a large 'Q' and several smaller marks.

In Item 415.001 on Page 13 of 44 of the Bills of Quantities the unit of measurement shall be amended from "cu. m" to "sq. m".

The removal of existing pavement in all other circumstances shall be measured as "Unclassified Excavation".]

**415.3 - METHOD OF MEASUREMENT:**

"Removing Existing Pavement Surface" shall be measured by the total number of square metres planed or ground, without regard to the number of passes or to the thickness of the material removed.

The work covered by Section 415 of the Technical Specifications shall consist of preparing the existing pavement for the placement of new courses of pavement for connection between local road relocations and existing roads pavements, and shall be as directed by the Engineer. The unit of measurement for such pavement removal shall be the square metre as provided for in the amendment to Sub-Section 415.5 by Bid Addendum No. 1. The average depth for such pavement removal is expected to be of the order of 200 mm.

In Item 415.001 on Page 13 of 44 of the Bills of Quantities the unit of measurement shall be amended from "cu. m" to "sq. m".

The removal of existing pavement in all other circumstances shall be measured as "Unclassified Excavation".

**415.4 - BASIS OF PAYMENT:**

The quantities, determined as provided above, will be paid for at the contract unit prices bid for the pay items listed below.

This price shall be full compensation for doing all the work prescribed in a workmanlike and acceptable manner, for removing existing pavement and disposal of excess material including all labour, tools, equipment, supplies, and incidentals necessary to complete the work for the following contract item.

**415.5 - PAY ITEM:**

ITEM	DESCRIPTION	UNIT
415.001	Removing existing pavement surface	Provisional Sum

*BS* *A*