



DEMOCRATIC SOCIALIST REPUBLIC OF SRI LANKA
MINISTRY OF PORTS & HIGHWAYS
ROAD DEVELOPMENT AUTHORITY
CHINESE DEVELOPMENT BANK FUNDED
IMPROVEMENT AND REHABILITATION OF PRIORITY ROAD PROJECT 1 (PRP1)
AGREEMENT FOR
CIVIL WORK CONTRACTS

CONTRACT NO. RDA/RNIP/PRP1/PACKAGE-A (C1A, C2A, C3, C6A & C8)

Component Ref. No.	Name of the Road
RDA/RNIP/PRP1/C1A	Improvement & Rehabilitation of B141 Beliatta - Tangalle Road (7.47 km) Improvement & Rehabilitation of Bopale Junction - Kiri Ibbanara - Udamauara Road (8.5 km) Construction of a flyover at Siribopura Junction
RDA/RNIP/PRP1/C2A	Improvement & Rehabilitation of B363 Pelawatta - Kankotiyawatta - Thiniyawala - Morawaka Road (47 km)
RDA/RNIP/PRP1/C3	Improvement & Rehabilitation of B421 Thiruwanaketiya - Agalawatta Road (33.45 km)
RDA/RNIP/PRP1/C6A	Improvement & Rehabilitation of A026 Kandy - Mahiyangana - Padiyathalawa Road (20.5 km)
RDA/RNIP/PRP1/C8	Improvement & Rehabilitation of B184 Kalkudah Road (5.63 km) Improvement & Rehabilitation of B185 Kalkudah.- Valachchenai Road (4.42 km)

BETWEEN

THE ROAD DEVELOPMENT AUTHORITY
OF SRI LANKA

AND

THE CHINA NATIONAL AERO TECHNOLOGY INTERNATIONAL
ENGINEERING CORPORATION (CATIC-ENG) OF CHINA

*Certified as True Copy
of 13 pages.*

VOLUME 4

The Drawings

W. T. I. N. TISSERA
Project Director (CDB - PRP 3)
Road Development Authority

21 DECEMBER 2010

5 P

Road Name	Carriageway Width	Hard Shoulder Width	Earth Shoulder Width
Beliatta- Tangalle	7.0	1.0 x 2	1.0 x 2
Kiri - Ibbanara- Udamaura	7.0	-	1.0 x 2
Pelawatta- Kankotiyawatta- Thiniyawala- Morawaka	6.2	-	1.0 x 2
Thiriwanaketiya Agalawatta	6.2	-	1.0 x 2
Kandy- Mahiyangana- Padiyathalawa	7.0	1.0 x 2	1.0 x 2
Kalkudah road	6.2	-	1.0 x 2
Kalkudah- Valachchenai	6.2	-	1.0 x 2

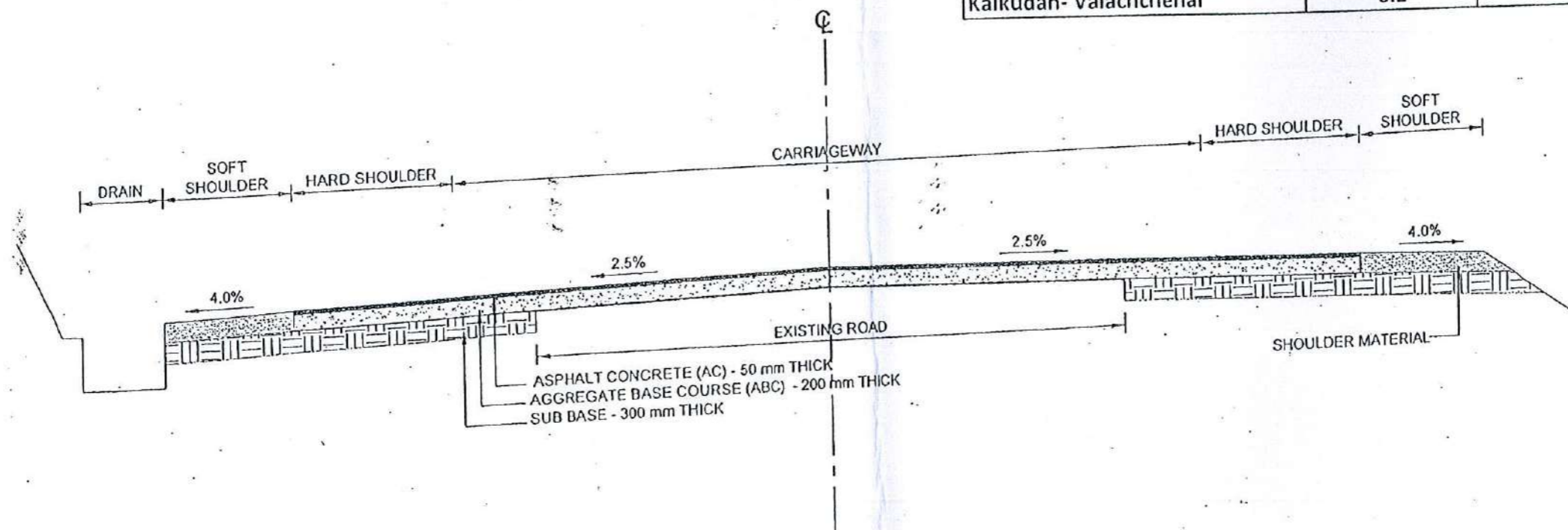

TYPICAL CROSS SECTION
NOT TO SCALE

CLIENT: DEMOCRATIC SOCIALIST REPUBLIC OF SRILANKA
MINISTRY OF PORTS & HIGHWAYS
Road Development Authority

PROJECT: PRIORITY ROADS PROJECT - 1
DRAWING TITLE: INSTALLATION OF TRAFFIC SIGNS

REV	DESCRIPTION	BY	DATE

SCALE: _____
DRAWN: N.THEEPAN
DATE: _____
DRAWING NO: _____

NOTES:-

1. THE RETRO-REFLECTIVE SIGN SHALL BE DIAMOND TYPE.
2. ALL DIMENSION ARE IN mm. UNLESS OTHERWISE STATED.

SITING DETAILS OF WARNING SIGNS

TRAVEL SPEED km/h	CLEAR VISIBILITY DISTANCE (m)	DISTANCE FROM SIGN TO HAZARD (m)
30	60	45
40	60	45
50	60	60
60	60	100
80	75	160

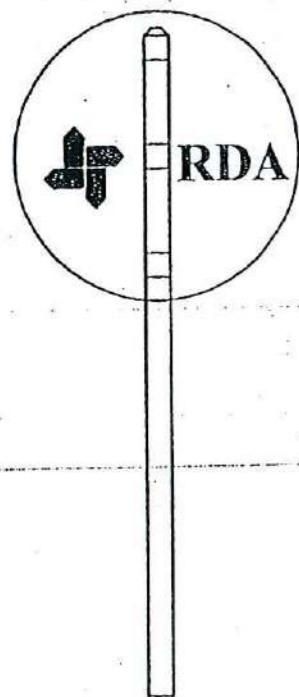

REAR SIDE

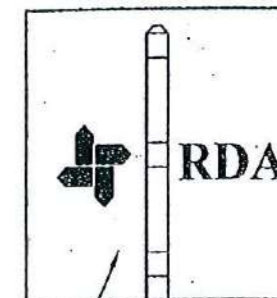
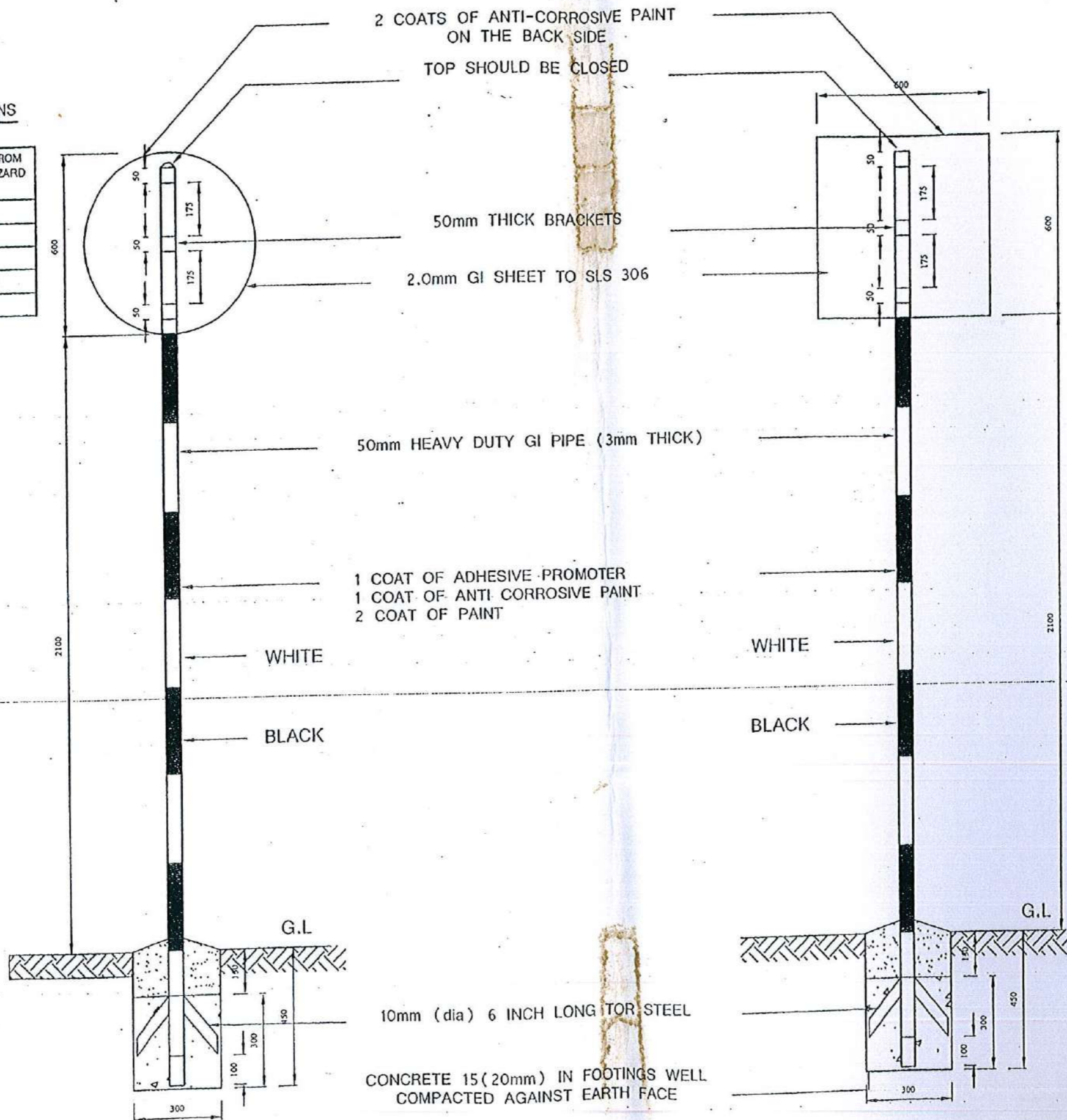

WHITE IN COLOUR

REAR SIDE

REV	DESCRIPTION	BY	DATE

SCALE :	
DRAWN: N.THEEPAN	DESIGNED:
DATE:	CHECKED:
DRAWING NO:	

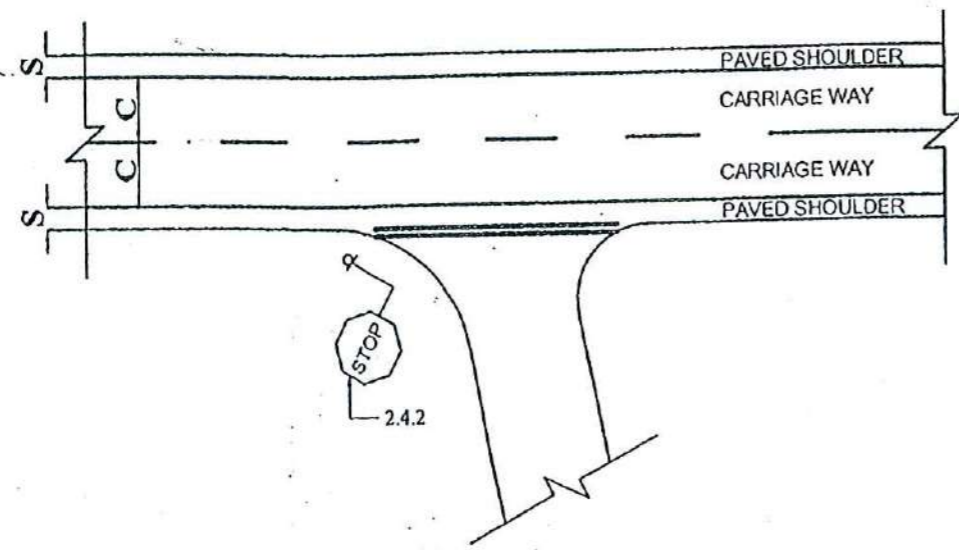

TYPE 1 - MINOR ROAD LESS THAN 6m WIDE

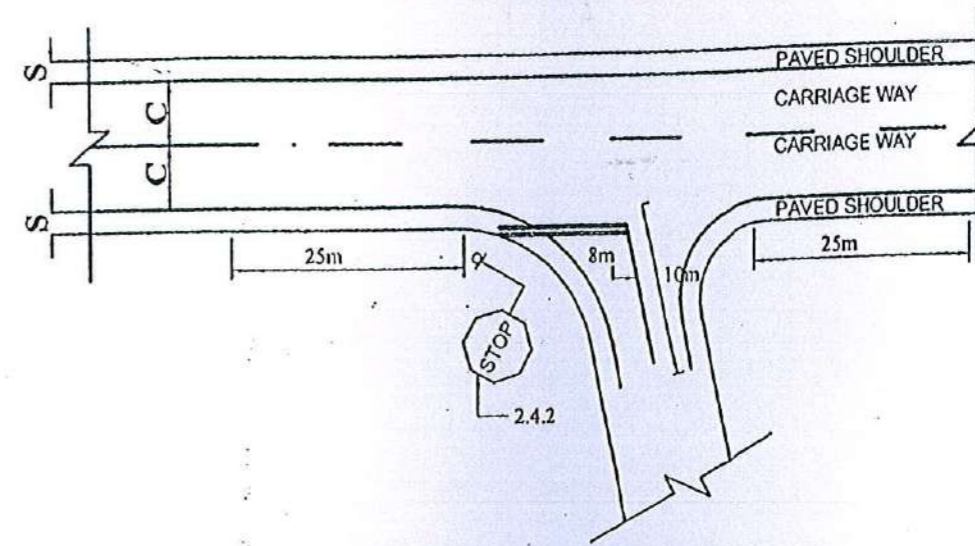

TYPE 2 - MINOR ROAD MORE THAN 6m WIDE

BY- ROAD IS A MINOR ROAD

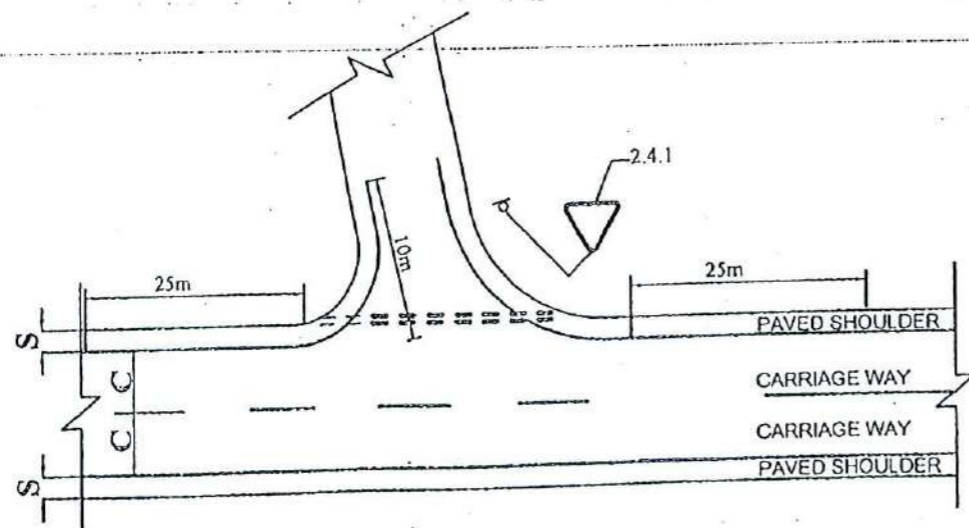

TYPE 3 - MAJOR ROAD LESS THAN 6m WIDE

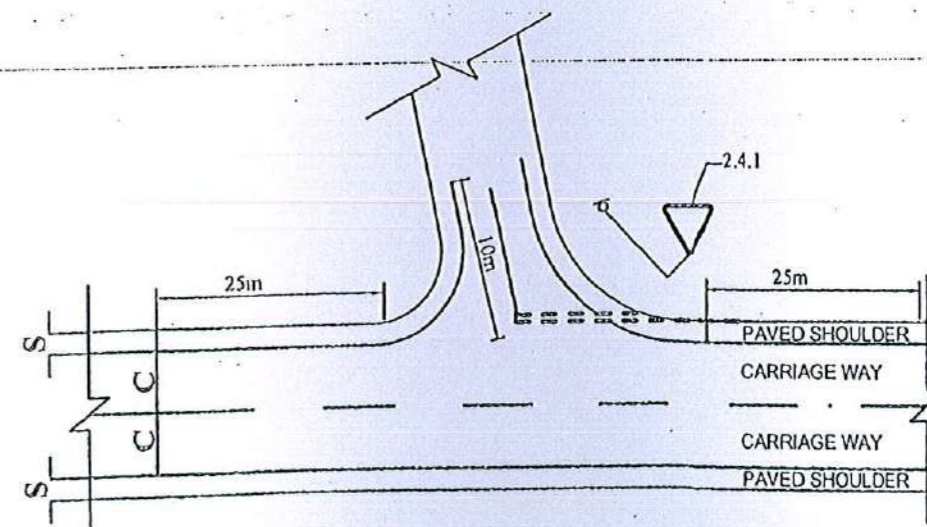

TYPE 4 - MAJOR ROAD MORE THAN 6m WIDE

BY- ROAD IS A MAJOR ROAD

CLIENT:

DEMOCRATIC SOCIALIST REPUBLIC OF SRILANKA
MINISTRY OF PORTS & HIGHWAYS
Road Development Authority



PROJECT

PRIORITY ROADS PROJECT - 1

DRAWING TITLE

ROAD MARKINGS AND SIGNS AT THE BY ROADS

REV	DESCRIPTION	BY	DATE

SCALE :

DRAWN: G.THEVA

DESIGNED:

DATE:

CHECKED:

DRAWING NO:

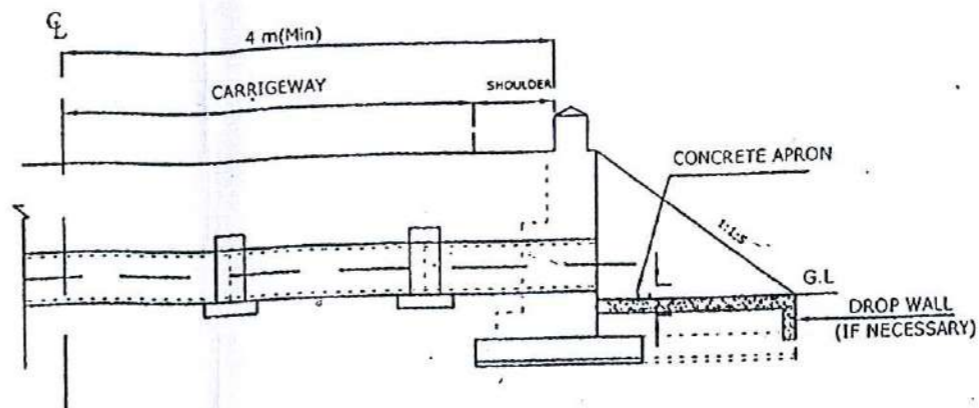
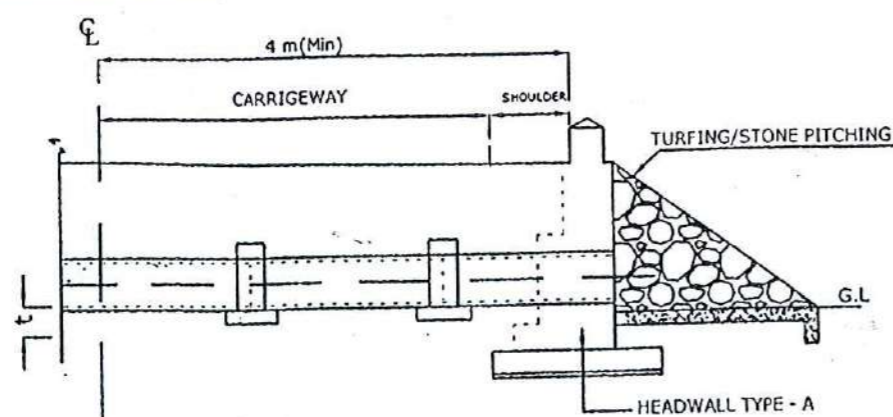

HALF SECTIONAL ELEVATION

NOTES :-

1. ALL THE DIMENSIONS ARE IN mm UNLESS OTHERWISE STATED.
2. TYPE OF HEAD WALL SHALL BE DECIDED BY THE ENGINEER TO SUIT THE SITE CONDITIONS.
3. PIPES SHALL BE LAID TO AGRADIENT OF 1 IN 200.
4. COLLARS TO BE USED IN CASE OF PIPES WITHOUT TONGUE AND GROVE.
5. SLOPE OF EMBANKMENT FILL TO BE 1:1.5 OR AS AS DIRECTED AT SITE BY THE ENGINEER.
6. PRE CAST CONCRETE GUARD STONES SHALL BE FIXED AT 1500 C/C OR AS DIRECTED BY THE ENGINEER.
7. TYPE OF EMBANKMENT PROTECTION TO BE AS DIRECTED BY THE ENGINEER.

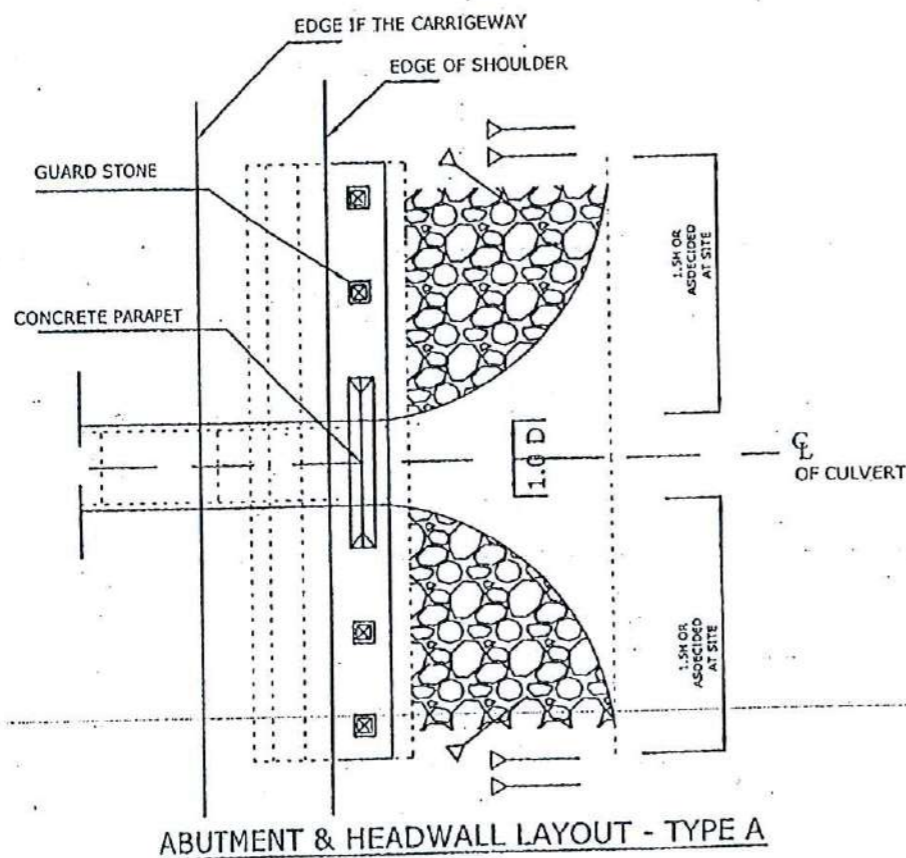

ABUTMENT & HEADWALL LAYOUT - TYPE A

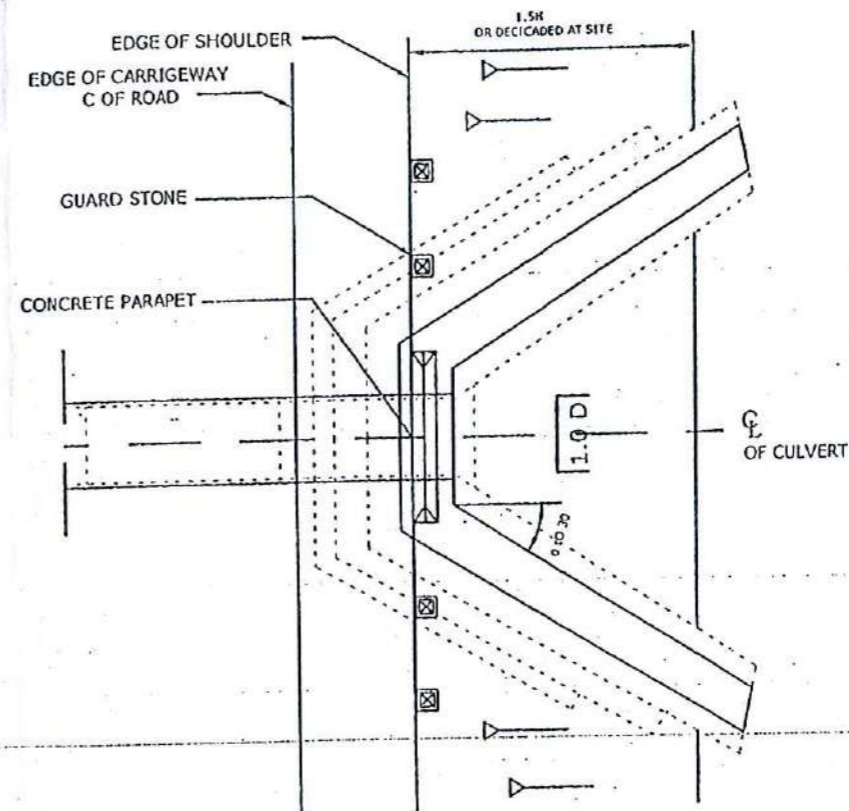

ABUTMENT & HEADWALL LAYOUT - TYPE B

t	
INLET	OUTLET
0	75

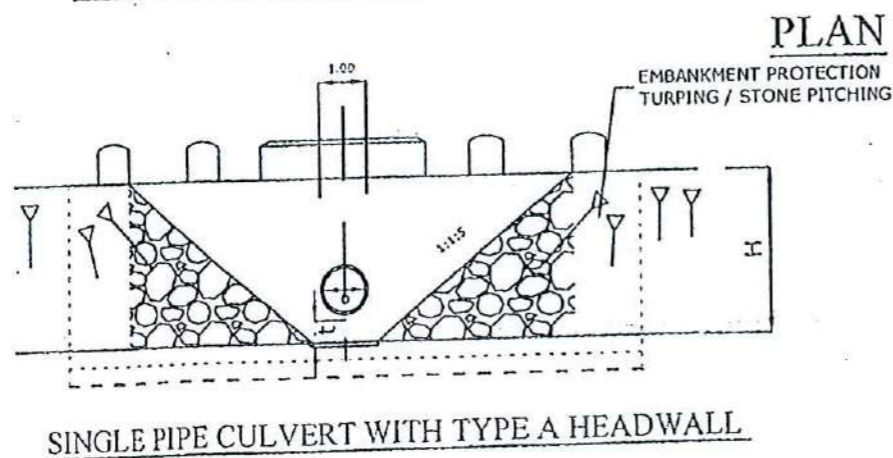

SINGLE PIPE CULVERT WITH TYPE A HEADWALL

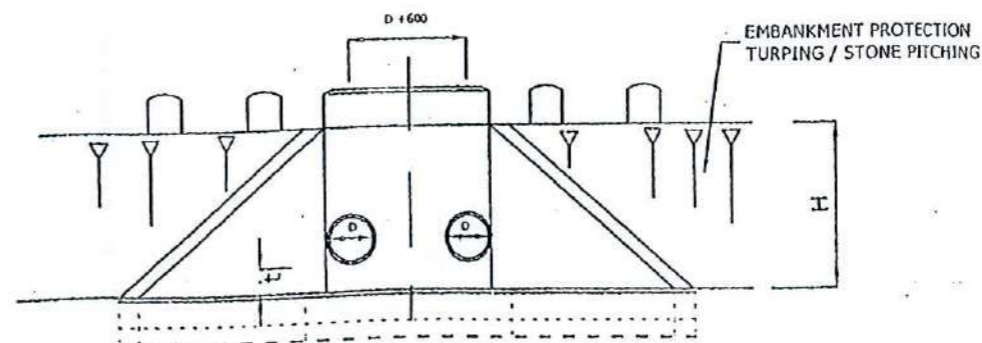

TWIN PIPE CULVERT WITH TYPE B HEADWALL

ELEVATION

CLIENT:

DEMOCRATIC SOCIALIST REPUBLIC OF SRILANKA
MINISTRY OF PORTS & HIGHWAYS
Road Development Authority

PROJECT

PRIORITY ROADS PROJECT - 1

DRAWING TITLE

TYPICAL PIPE CULVERT

REV	DESCRIPTION	BY	DATE

SCALE AS SHOWN

DRAWN: N.THEEPAN DESIGNED:

DATE: CHECKED:

DRAWING NO:

5

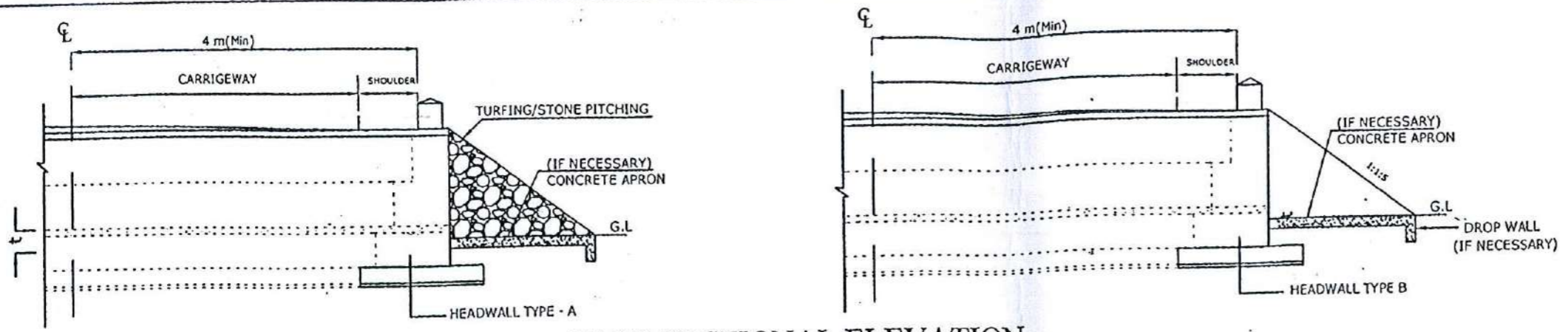

HALF SECTIONAL ELEVATION

- NOTES :-**
1. ALL THE DIMENSIONS ARE IN mm UNLESS OTHERWISE STATED.
 2. ABUTMENT BASE AND CONCRETE LINING SHALL BE STEPPED IF NECESSARY AS APPROVED BY THE ENGINEER.

t	
INLET	OUTLET
0	75

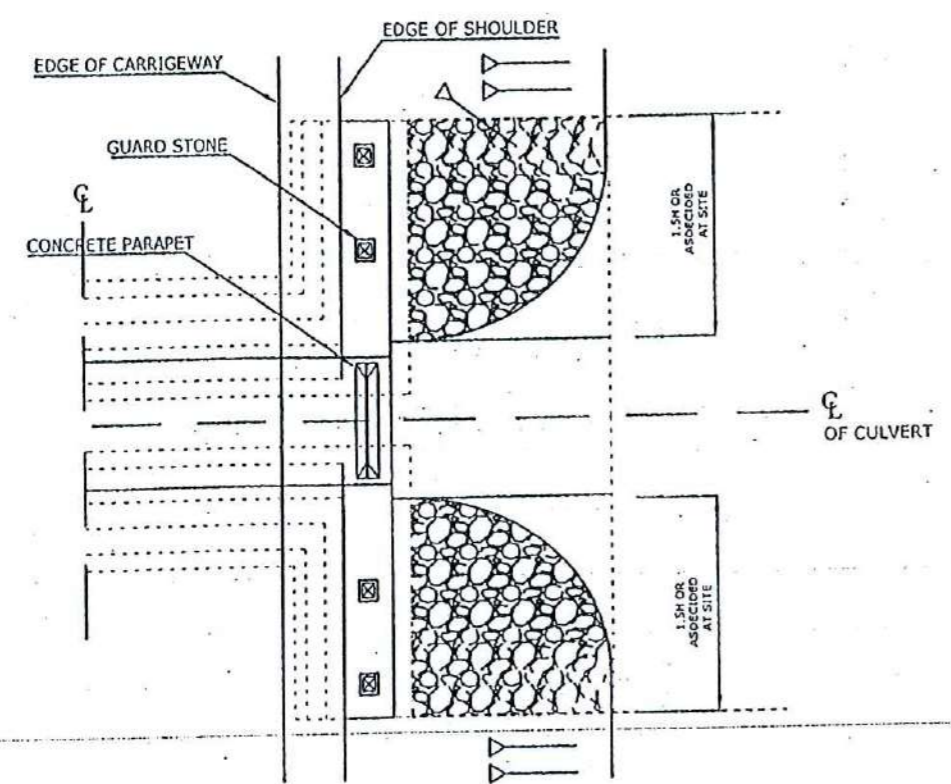

ABUTMENT & HEADWALL LAYOUT - TYPE A

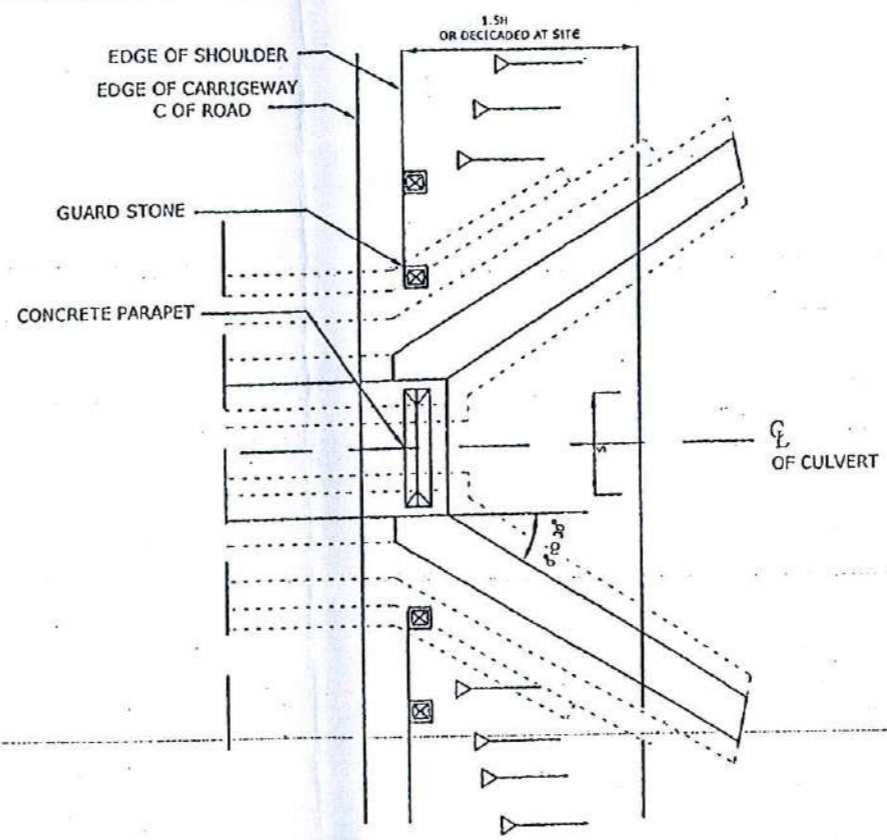

ABUTMENT & HEADWALL LAYOUT - TYPE B

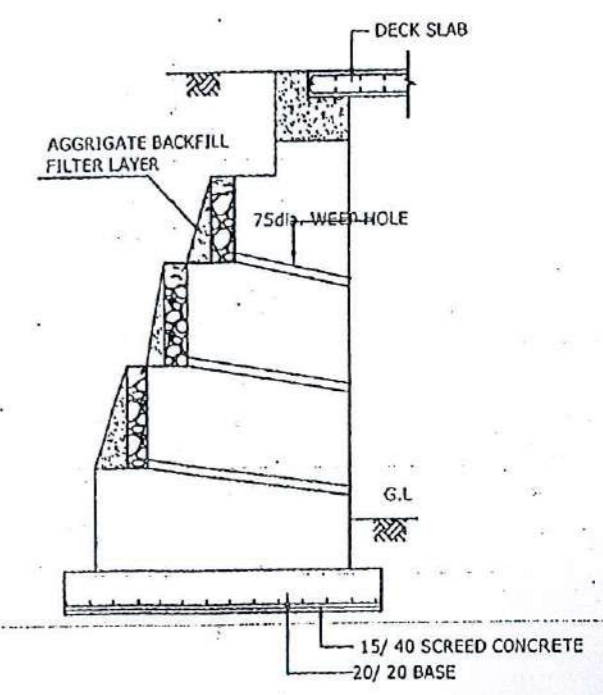

TYPICAL DECK CULVERT ABUTMENT

PLAN

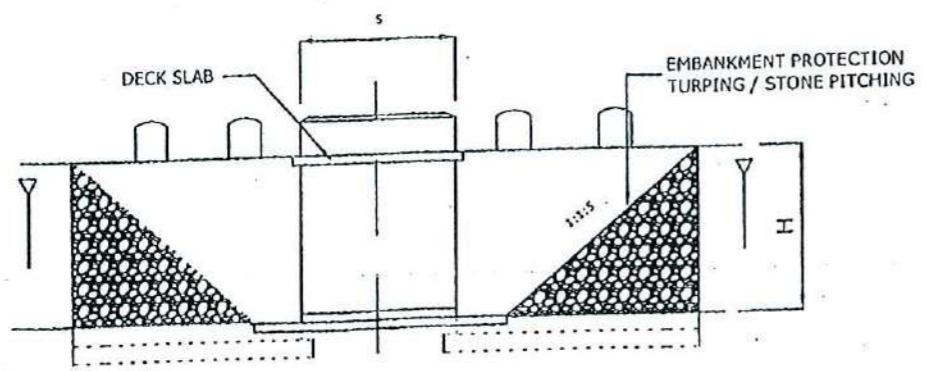

SLAB CULVERT WITH TYPE A HEADWALL

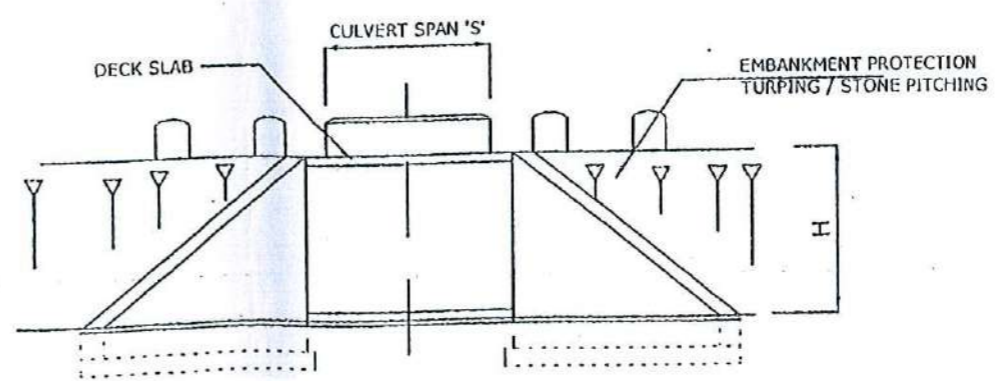

SLAB CULVERT WITH TYPE B HEADWALL

ELEVATION

CLIENT: DEMOCRATIC SOCIALIST REPUBLIC OF SRILANKA
 MINISTRY OF PORTS & HIGHWAYS
 Road Development Authority

PROJECT: ADE
 PRIORITY ROADS PROJECT - 1
 DRAWING TITLE: TYPICAL DECK CULVERT

REV	DESCRIPTION	BY	DATE

SCALE AS SHOWN
 DRAWN: N.THEEPAN
 DATE: CHECKED:
 DESIGNED:
 DRAWING NO:

56

NOTES :

1. THIS DRAWING PROVIDES A GUIDANCE ONLY. EXACT DETAILS TO SUIT SITE CONDITIONS, SHALL BE DECIDED BY THE ENGINEER AT CONSTRUCTION STAGE.
2. BOX OPENING SIZE (h & w) MUST BE GREATER THAN OR EQUAL TO THE MINIMUM REQUIRED OPENING SIZE.
3. EXACT WALL THICKNESS (ts, tw, tb and ti) AND R/F MUST BE DECIDED TO SUIT THE SITE CONDITION AND LOADING.
4. CONCRETE GRADE SHALL BE GR. 25(20).

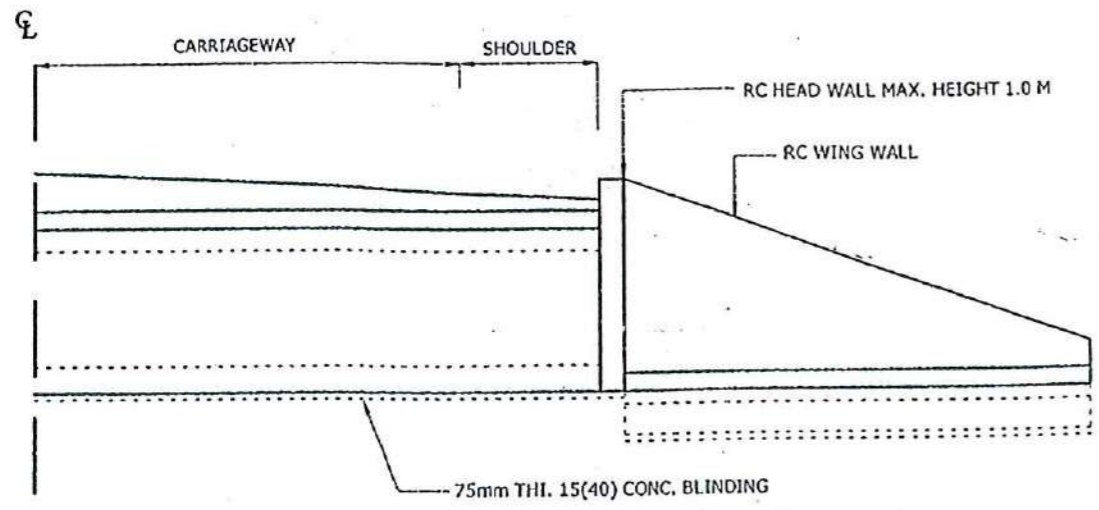

HALF ELEVATION

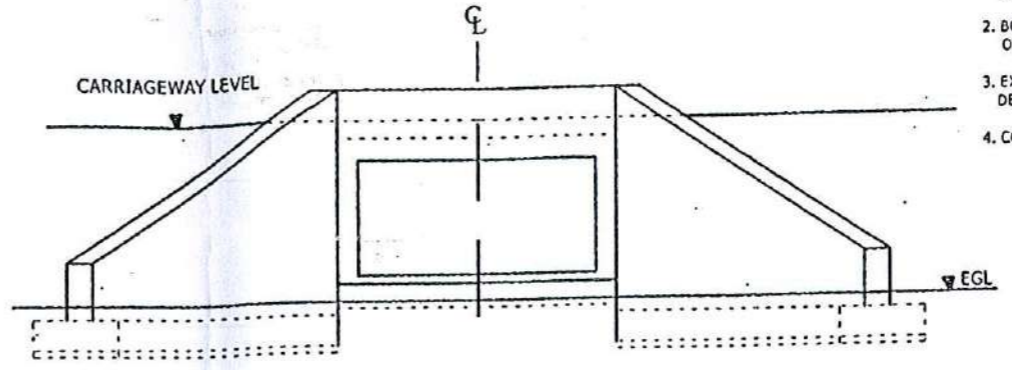

ELEVATION

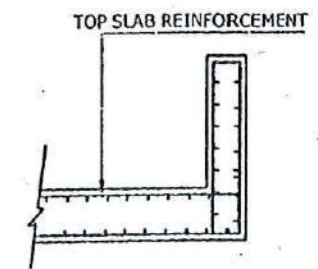

DETAIL OF HEADWALL

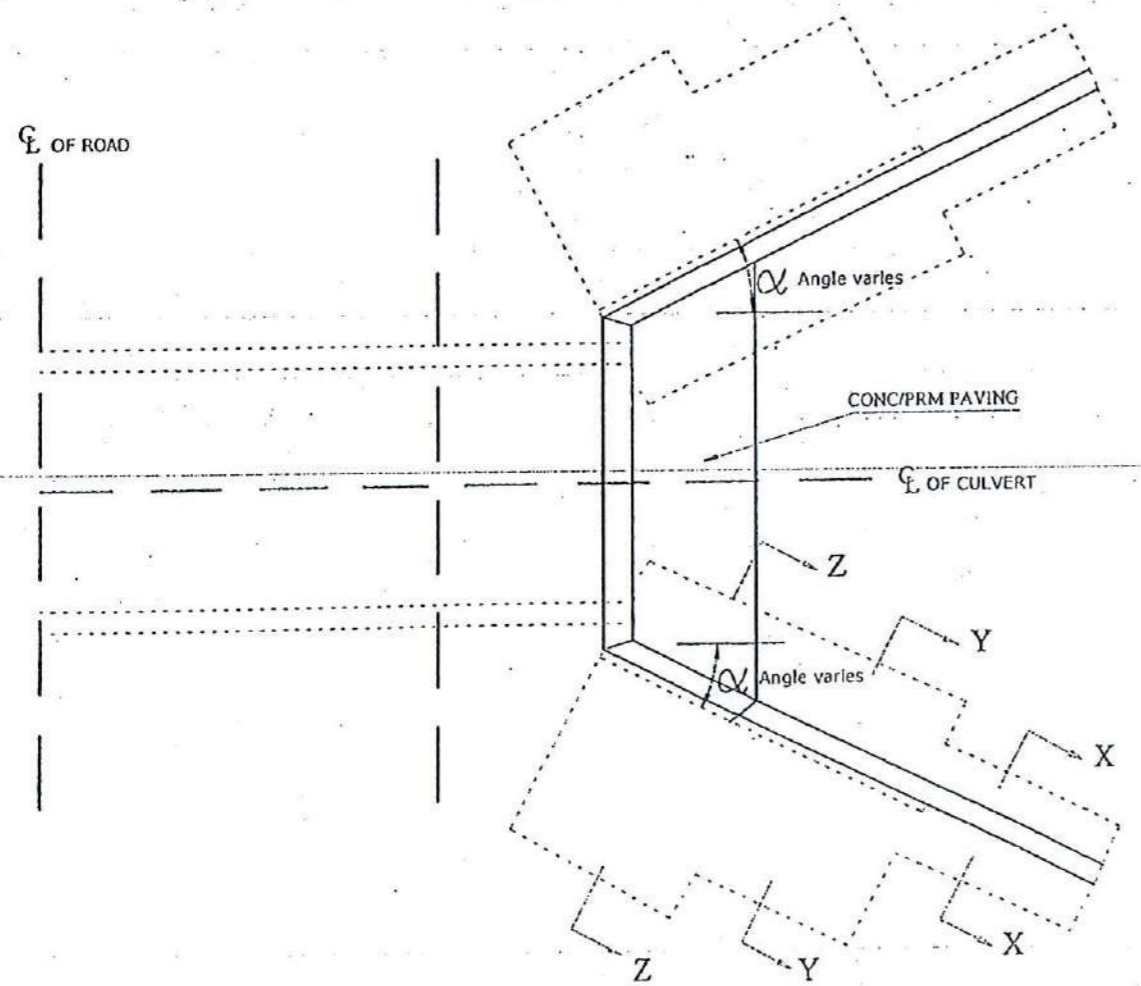

PLAN

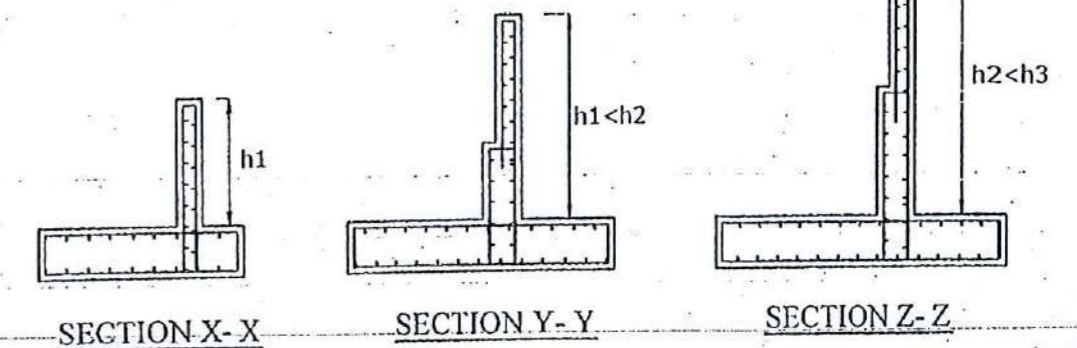

TYPICAL WINGWALL SECTIONS

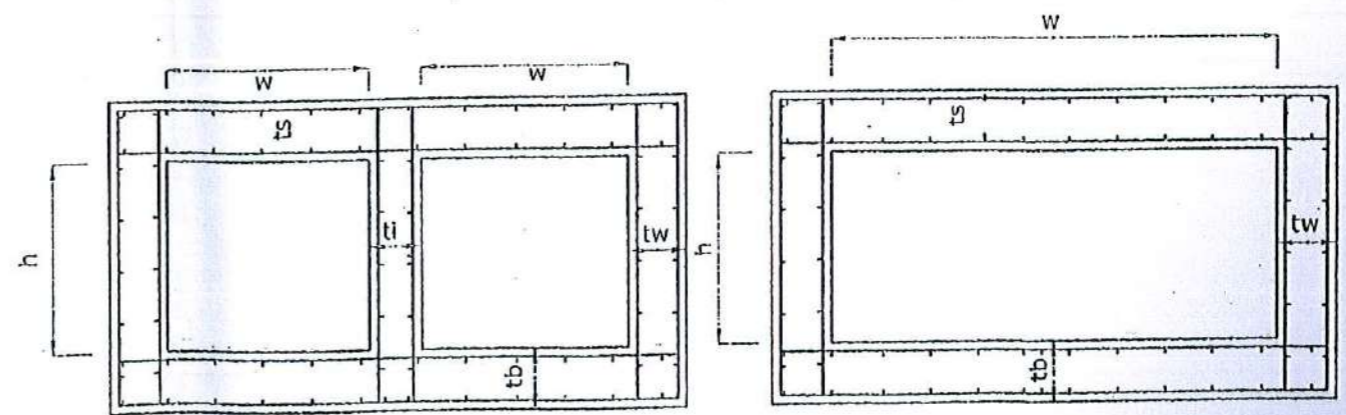

TWIN BOX TYPE

SINGLE BOX TYPE

CLIENT: DEMOCRATIC SOCIALIST REPUBLIC OF SRILANKA
 MINISTRY OF PORTS & HIGHWAYS
 Road Development Authority

PROJECT: PRIORITY ROADS PROJECT - 1
 DRAWING TITLE: TYPICAL RCC BOX CULVERT

SCALE AS SHOWN			
DRAWN: G.THEVA	DESIGNED:		
DATE:	CHECKED:		
DRAWING NO:			
REV	DESCRIPTION	BY	DATE

5/7

PROJECT: PRIORITY ROADS PROJECT - 1

DRAWING TITLE: TYPICAL CULVERT INLETS CONNECTING BUILD UP DRAINS

REV	DESCRIPTION	BY	DATE

SCALE AS SHOWN

DESIGNED: S. AATHI
 CHECKED:
 DATE:
 DRAWING NO:
 PROJECT: PRIORITY ROADS PROJECT - 1

TYPICAL R/F ARRANGEMENT FOR CULVERT INLETS

TYPICAL R/F ARRANGEMENT FOR TYPE - 1

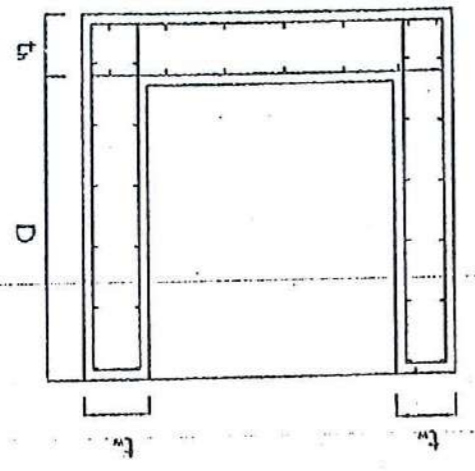

TYPICAL R/F ARRANGEMENT FOR TYPE - 2

TYPICAL R/F ARRANGEMENT FOR TYPE - 2

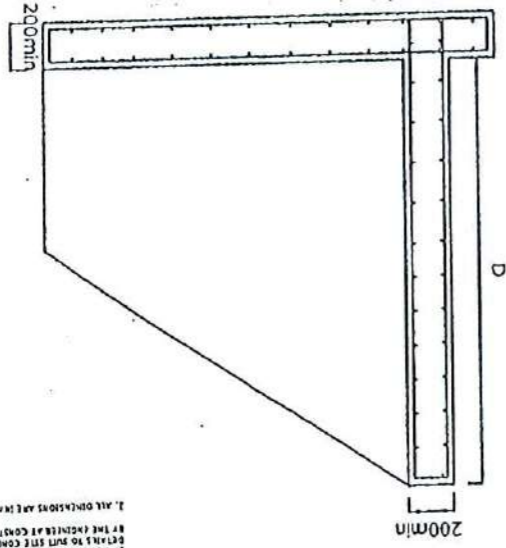

PLAN

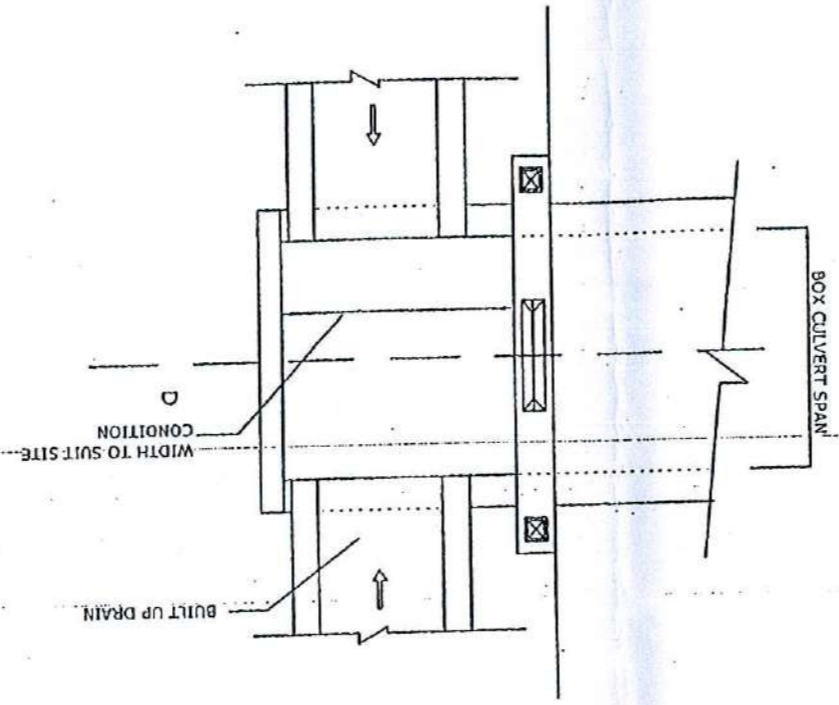

SECTION

TYPICAL R/F ARRANGEMENT FOR TYPE - 1

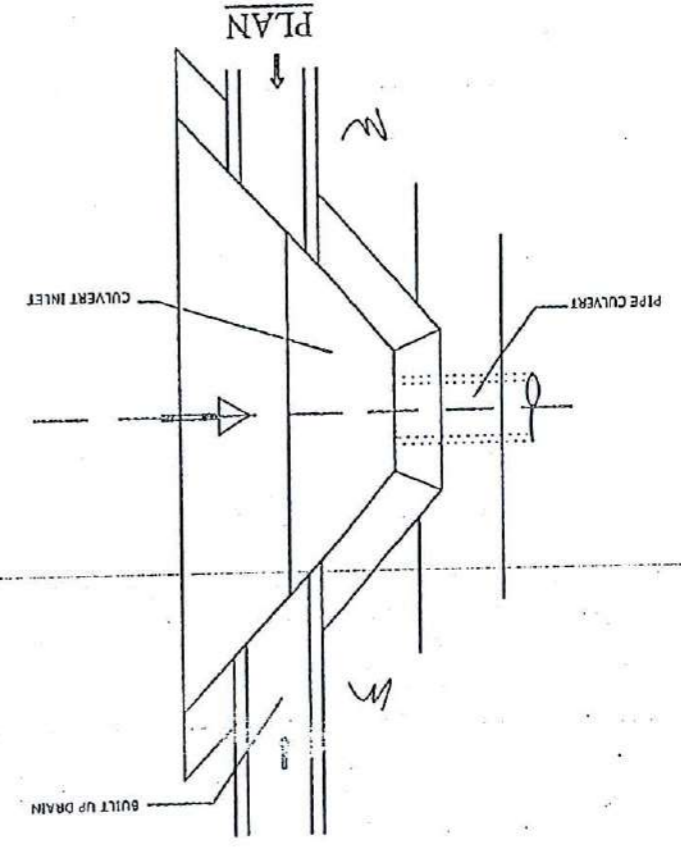

SECTION

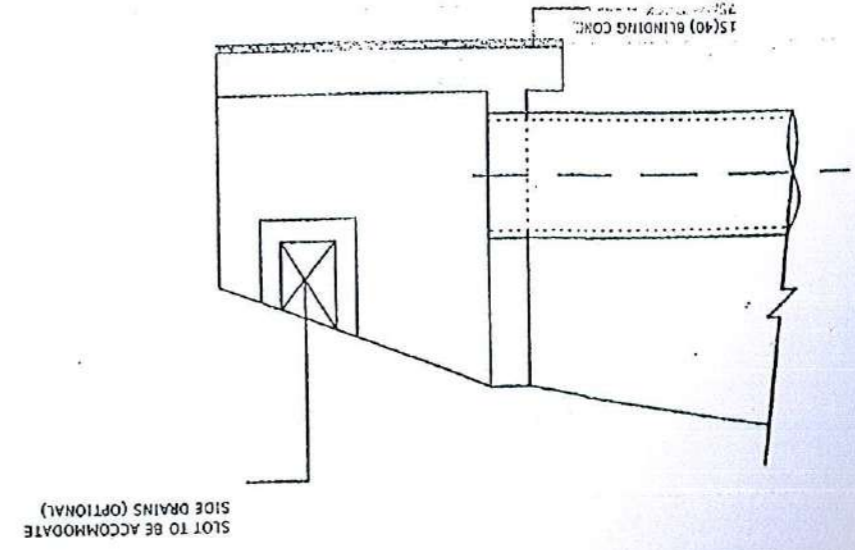
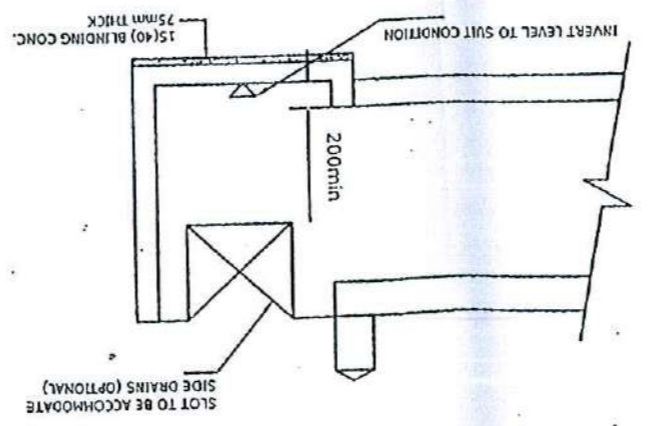

NOTES:
 1. THIS DRAWING PROVIDES A GUIDANCE ONLY
 2. ALL DIMENSIONS ARE IN MM.
 3. THE FACILITIES AT CONSTRUCTION STAGE
 4. REFER TO SUIT THE CONDITION, SHALL BE DECIDED

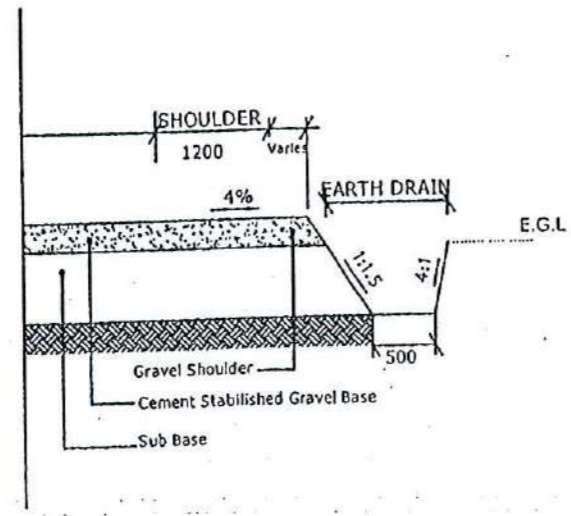

EARTH DRAIN

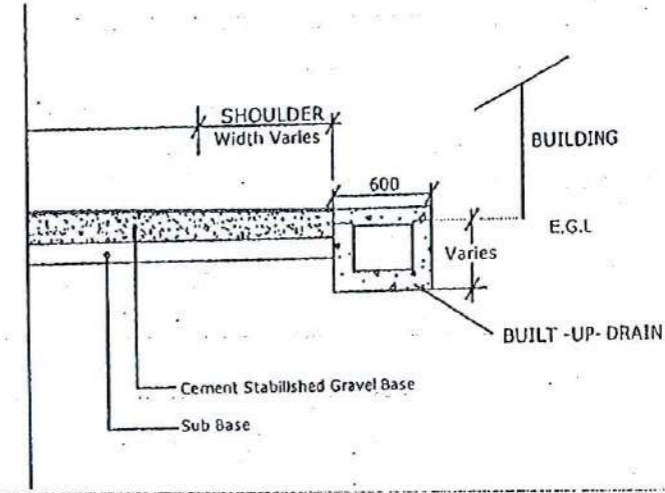

BUILT UP DRAIN WITH COVER

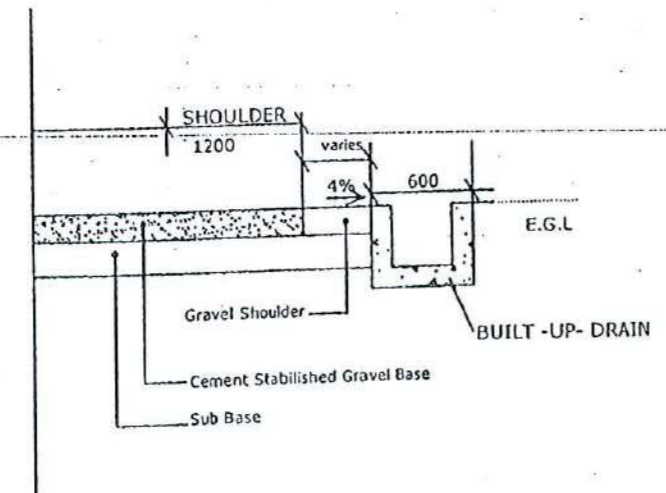

BUILT UP DRAIN

CLIENT: DEMOCRATIC SOCIALIST REPUBLIC OF SRILANKA
 MINISTRY OF PORTS & HIGHWAYS
 Road Development Authority

PROJECT: PRIORITY ROADS PROJECT - 1
 DRAWING TITLE: TYPICAL SIDE DRAINS

REV	DESCRIPTION	BY	DATE

SCALE : 1:50
 DRAWN: N.THEEPAN DESIGNED:
 DATE: CHECKED:
 DRAWING NO:

5 19

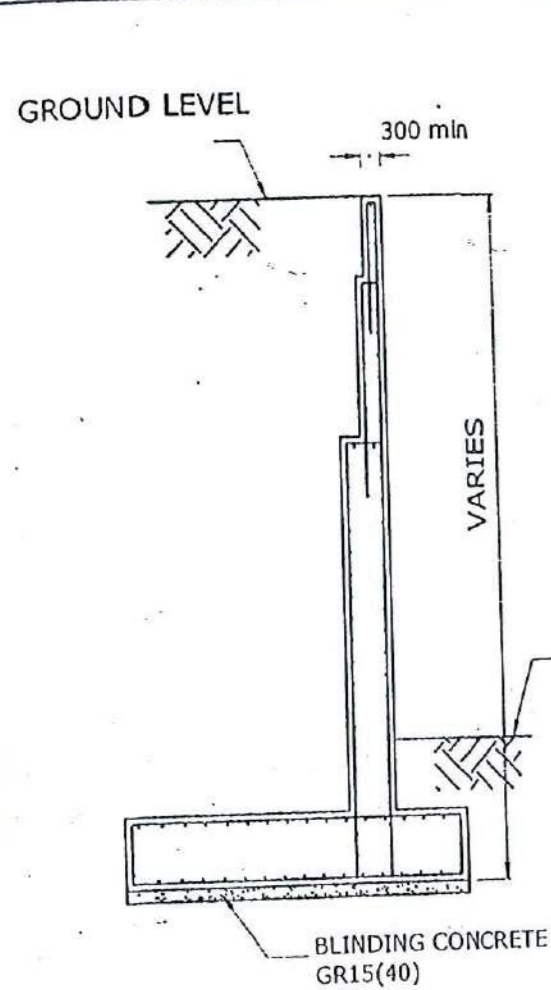

TYPICAL R/F RETAINING WALL

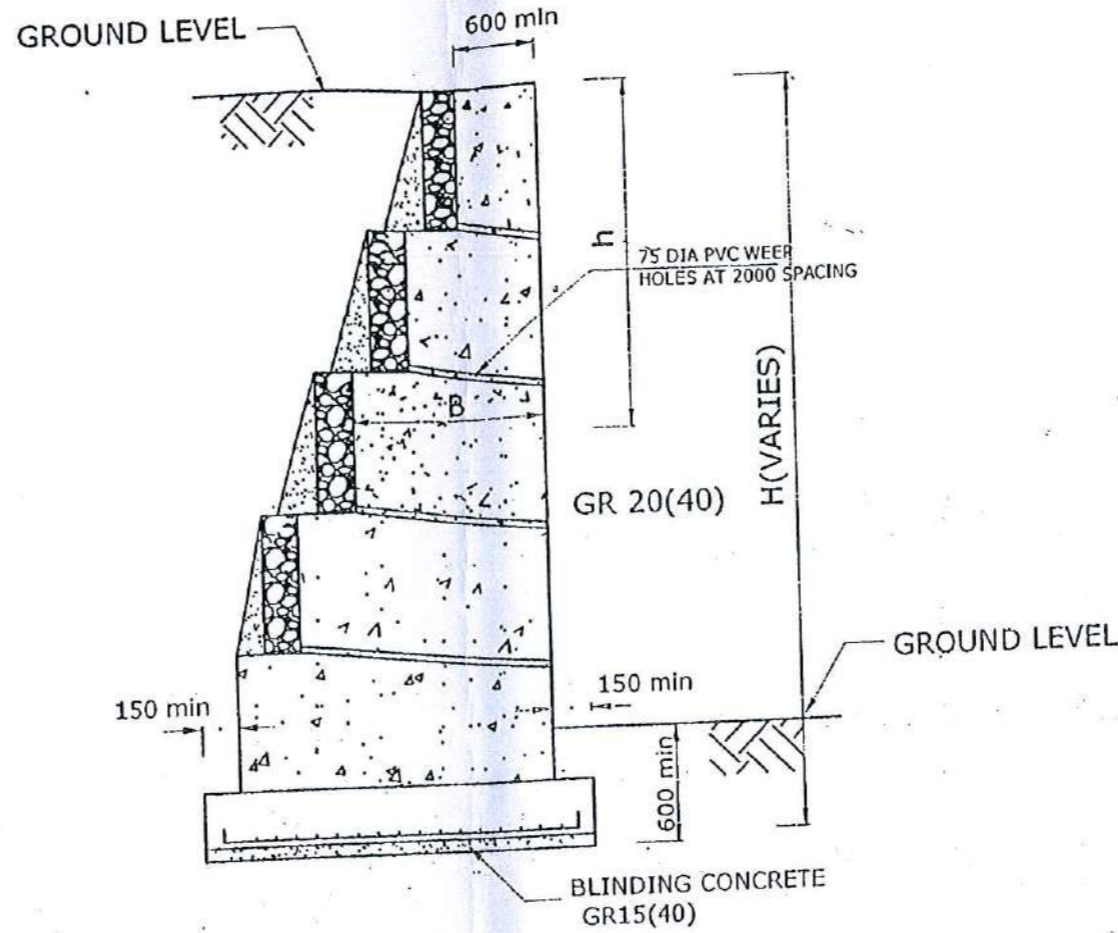

TYPICAL GRAVITY RETAINING WALL - TYPE 1

NOTE:

1. ALL DIMENSIONS ARE IN MILLIMETRES.
2. POROUS BACK FILL TO BE PROVIDED ALONG THE ENTIRE LENGTH OF THE WALL.
3. PROVIDE WEEP HOLES OF 75 MM. DIA. PVC PIPES OR OTHER APPROVED BY THE ENGINEER.
4. FOUNDATION DEPTH BELOW INVERT LEVEL SHALL BE DECIDED TO SUIT SITE CONDITIONS.
5. NO OF STEPPINGS FOR GRAVITY RETAINING WALL WILL VARY WITH THE -H.
6. GRAVITY RETAINING WALL TYPE -2 SHALL USE FOR WIDENING OF CAUSEWAYS, A CROSSING LAGOONS OR SEA.

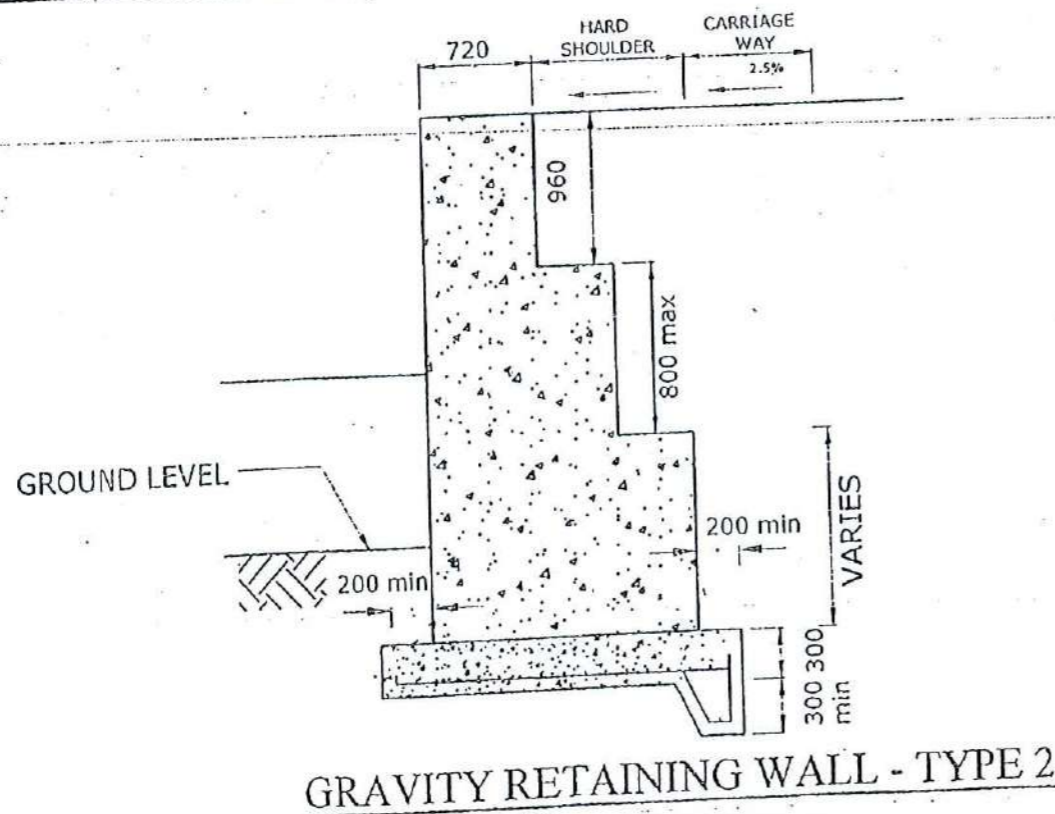

GRAVITY RETAINING WALL - TYPE 2

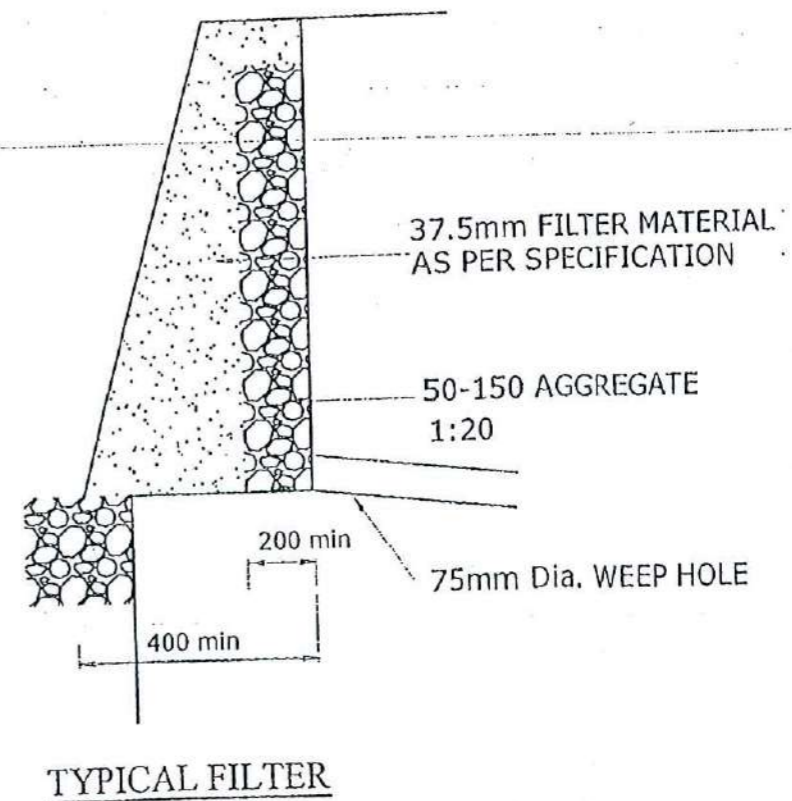

TYPICAL FILTER

CLIENT:

DEMOCRATIC SOCIALIST REPUBLIC OF SRI LANKA
MINISTRY OF PORTS & HIGHWAYS
Road Development Authority

PROJECT

PRIORITY ROADS PROJECT - 1

DRAWING TITLE

TYPICAL SECTION FOR RETAINING WALLS

SCALE AS SHOWN	
DRAWN: G.THEVA	DESIGNED:
DATE:	CHECKED:
DRAWING NO:	
REV	DESCRIPTION
BY	DATE

10

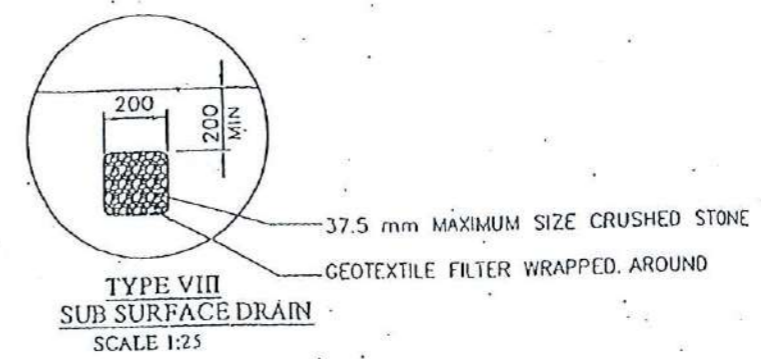
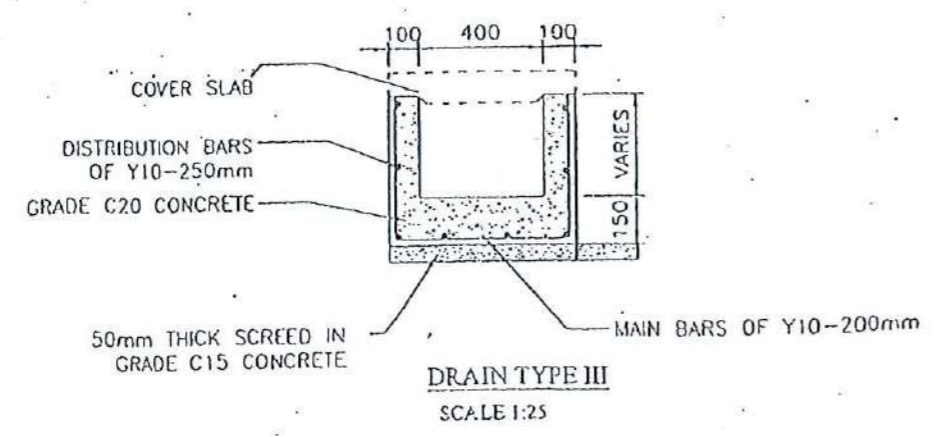
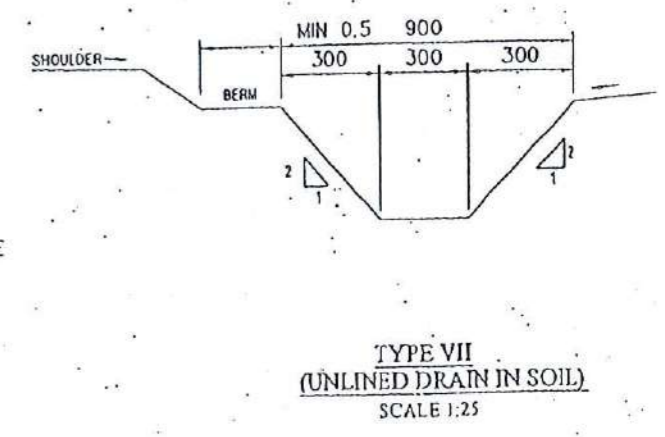
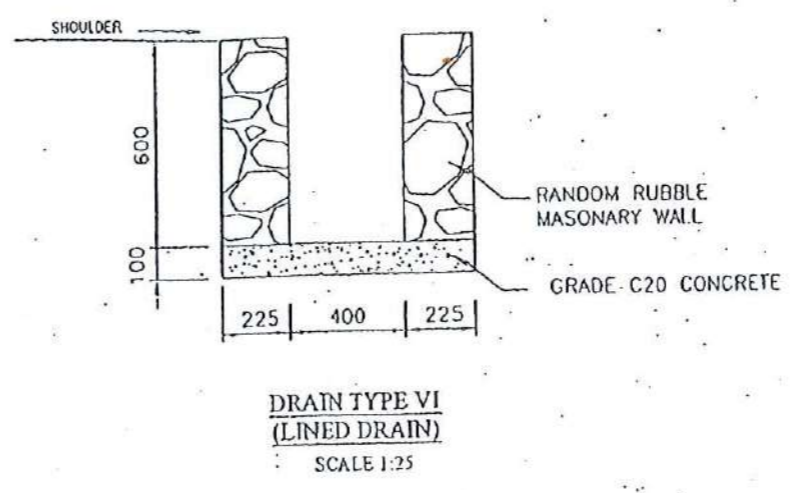
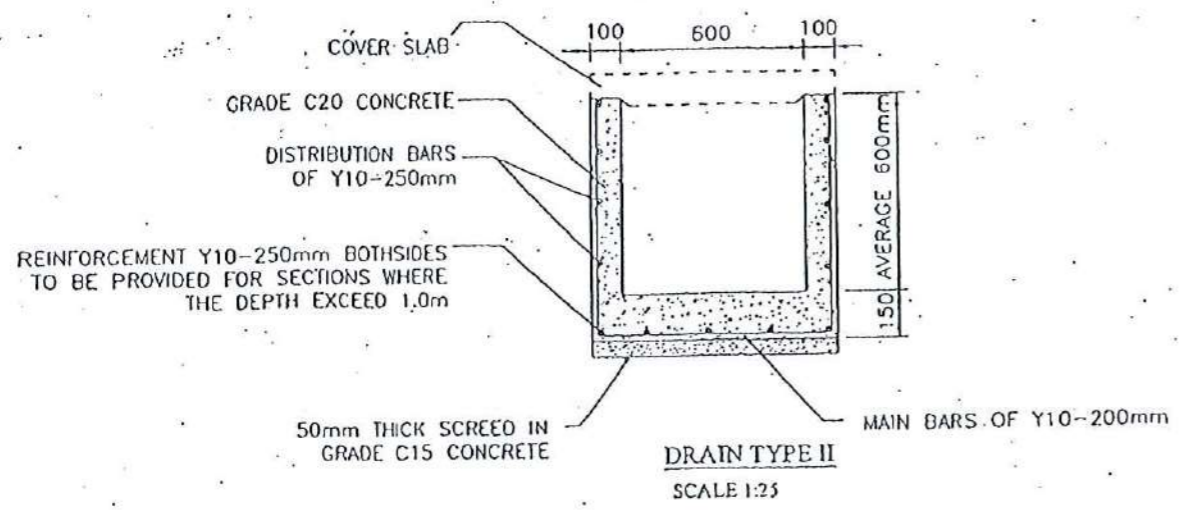
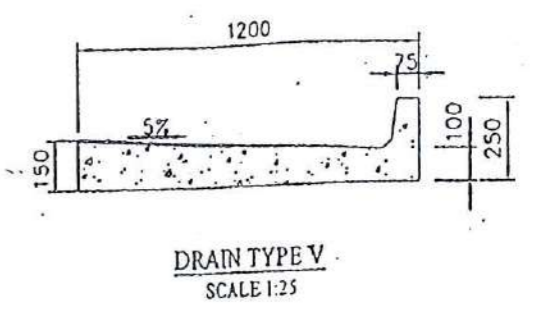
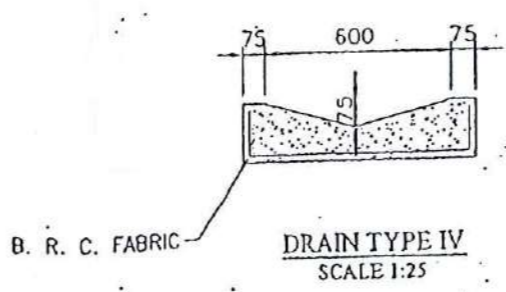
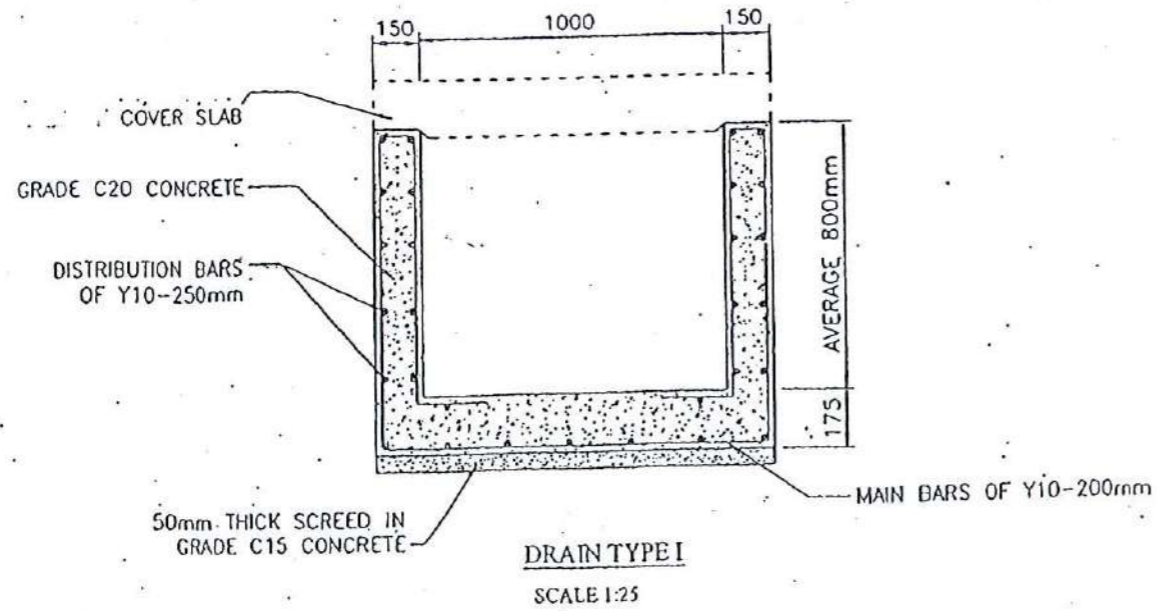

- NOTE:
- (i) THE DEPTHS OF DRAINS OF ALL TYPES ARE AS DETAILED AND TO SUIT SITE CONDITIONS.
 - (ii) TOP LEVEL OF DRAIN SECTION IS TO BE DETERMINED WITH RESPECT TO ROAD FINISHED LEVEL.
 - (iii) DRAIN TYPE (VII) IS TO BE ADOPTED IN REPAIRS OF EXISTING SECTIONS OF RANDOM RUBBLE MASONRY DRAINS. HOWEVER, IT COULD BE USED IN NEW SECTIONS SPECIALLY WHERE EXISTING RR MASONRY DRAINS HAVE TO BE EXTENDED.
 - (iv) SUBSOIL DRAIN TYPE VIII IS TO BE LAID ACROSS THE SHOULDERS. THESE DRAINS SHOULD NOT BE LAID UNDER CARSLAGWAY.

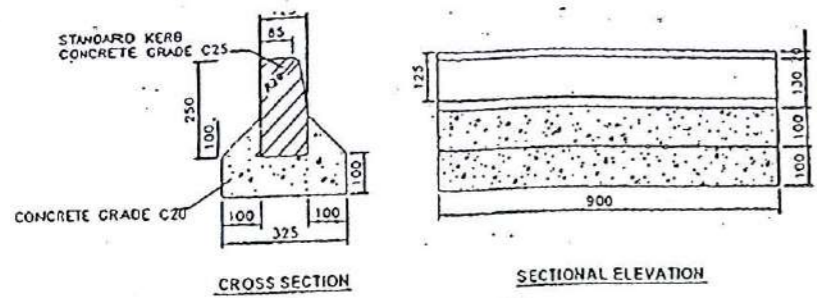

STANDARD KERB

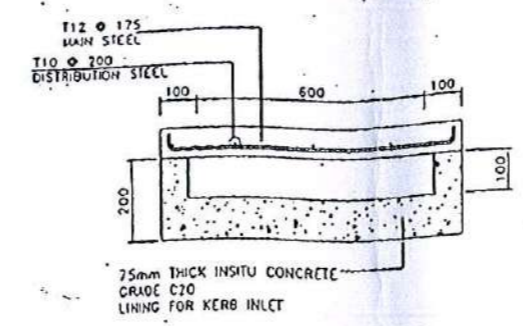

SECTIONAL ELEVATION OF KERB INLET

SCALE 1:10

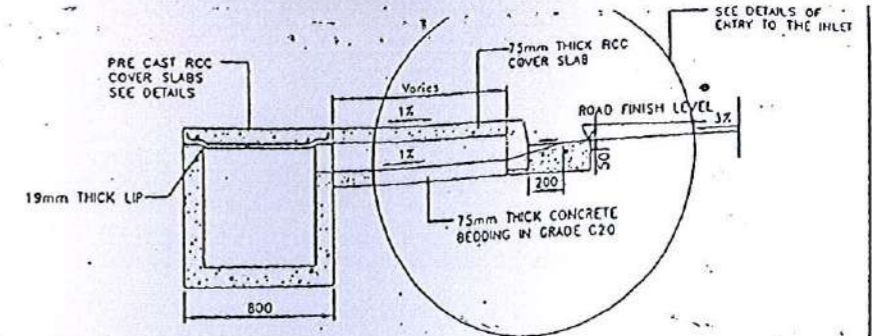

SECTIONAL ELEVATION ON Y-Y

SCALE 1:40

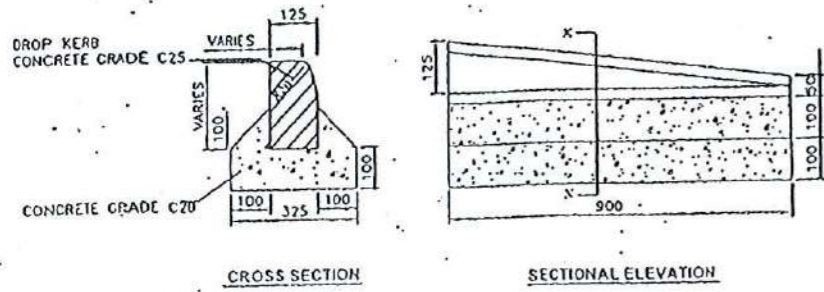

DROP KERB

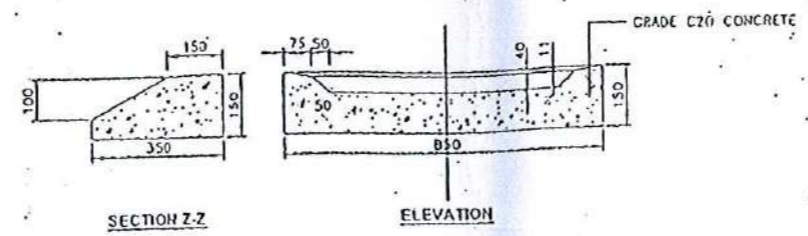

SECTION Z-Z

ELEVATION

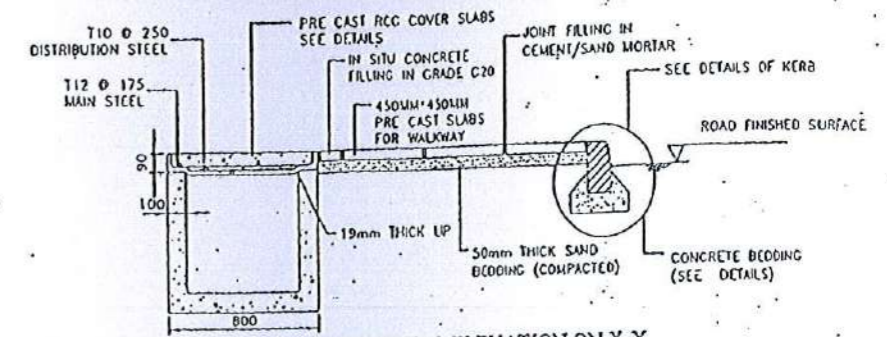

PART SECTIONAL ELEVATION ON X-X

SCALE 1:40

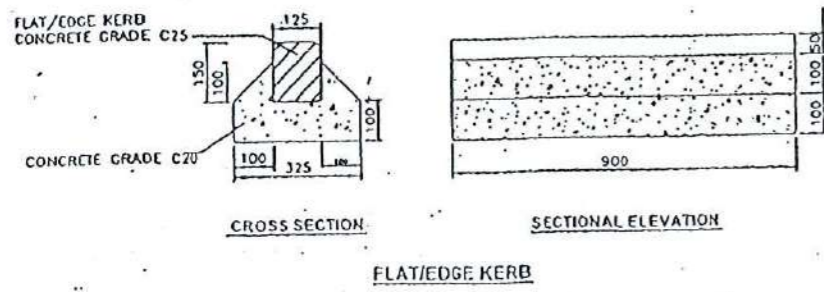

FLAT/EDGE KERB

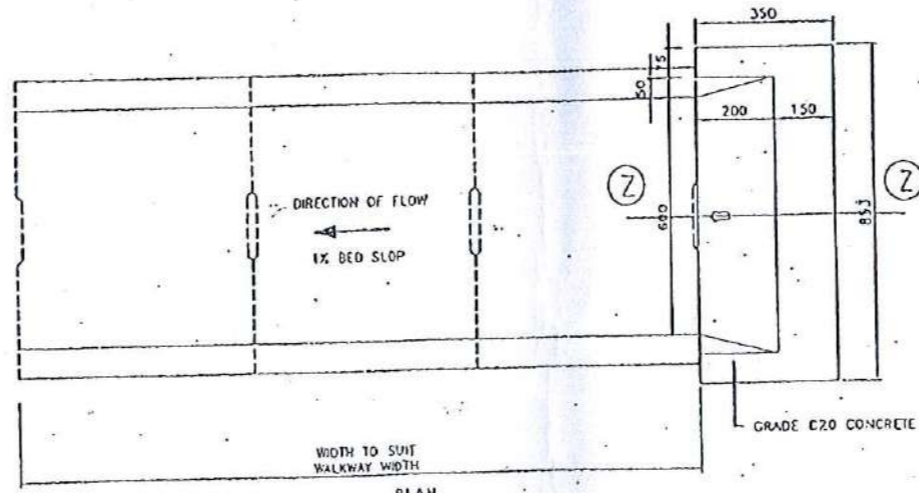

PLAN

DETAILS OF KERB INLET

SCALE 1:20

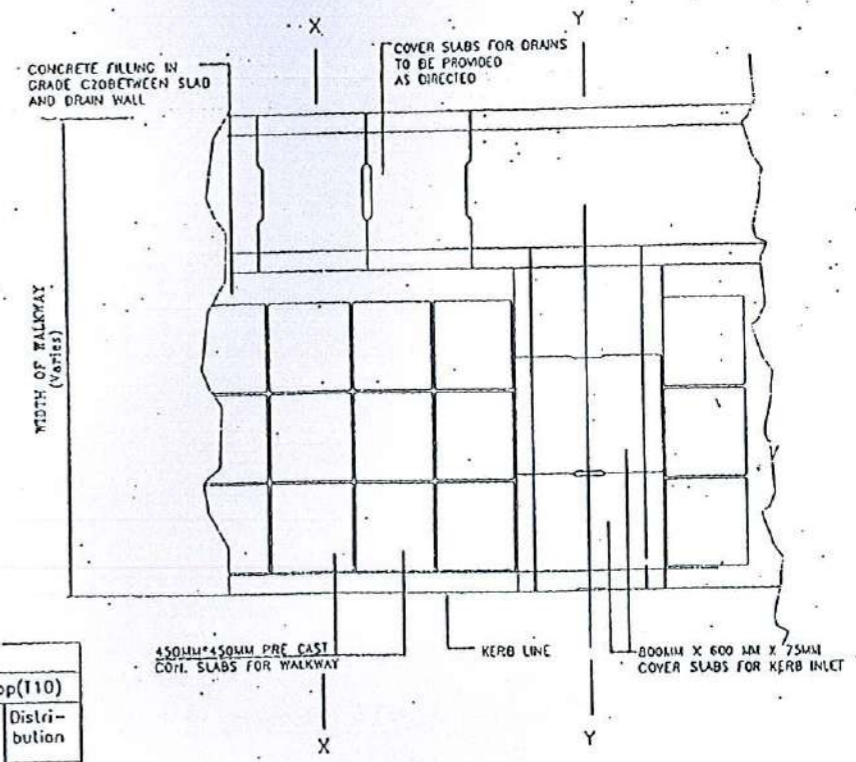

PLAN OF THE WALKWAY & THE KERB INLET

SCALE 1:40

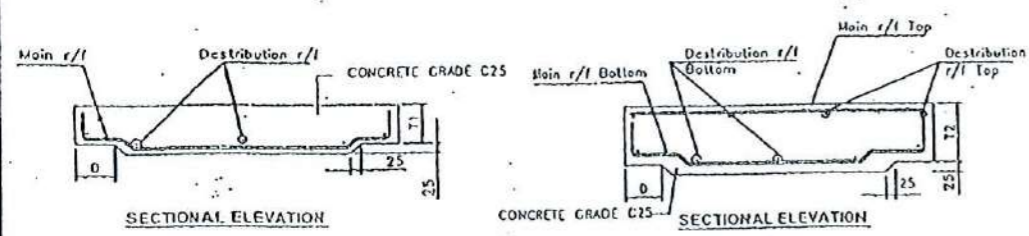

SECTIONAL ELEVATION

SECTIONAL ELEVATION

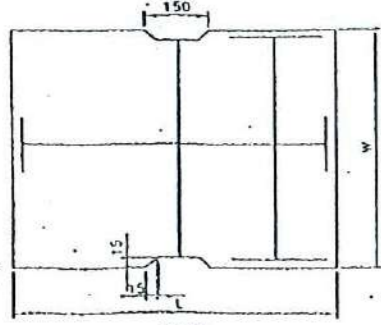

PLAN

PEDESTRIAN ACCESS

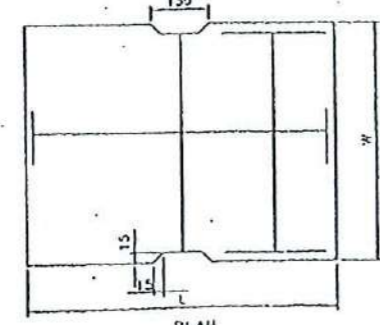

PLAN

VEHICULAR ACCESS

DRAIN TYPE	Slab		Pedestrian Access				Vehicular Access					
	Length L	Width W	T1	D	R/F (T10) Main	R/F (T10) Distri-bution	T2	D	R/F Bottom (T12) Main	R/F Top (T10) Distri-bution		
I	1300	600	125	150	5 Nos.	8 Nos.	150	150	5 Nos.	10 Nos.	5 Nos.	10 Nos.
II	800	600	75	100	5 Nos.	6 Nos.	125	100	5 Nos.	7 Nos.	5 Nos.	7 Nos.
III	600	500	75	100	5 Nos.	5 Nos.	100	100	5 Nos.	5 Nos.	5 Nos.	5 Nos.

TABLE 2: DETAILS OF COVER SLABS

* R/F = Reinforcement

- NOTE:
- (i) PLACEMENT OF RESPECTIVE COVER SLABS FOR PEDESTRIAN & VEHICULAR ACCESS TO BE DECIDED AT SITE.
 - (ii) KERB INLETS SHOULD BE SPACED AT 12M INTERVALS
 - (iii) ALL DIMENSIONS ARE IN MILLIMETERS UNLESS OTHERWISE SPECIFIED.